

THIS DOCUMENT IS A COPY AND IS NOT THE SOURCE DOCUMENT. INFORMATION IS SUBJECT TO CHANGE WITHOUT NOTICE. THE INFORMATION CONTAINED HEREIN IS COPYRIGHTED BY HAROLD BECK AND SONS, INC. CHANGES TO THE DOCUMENT ARE PROHIBITED. CONTACT A BECK SALES ENGINEER IF A CERTIFIED DRAWING IS REQUIRED.

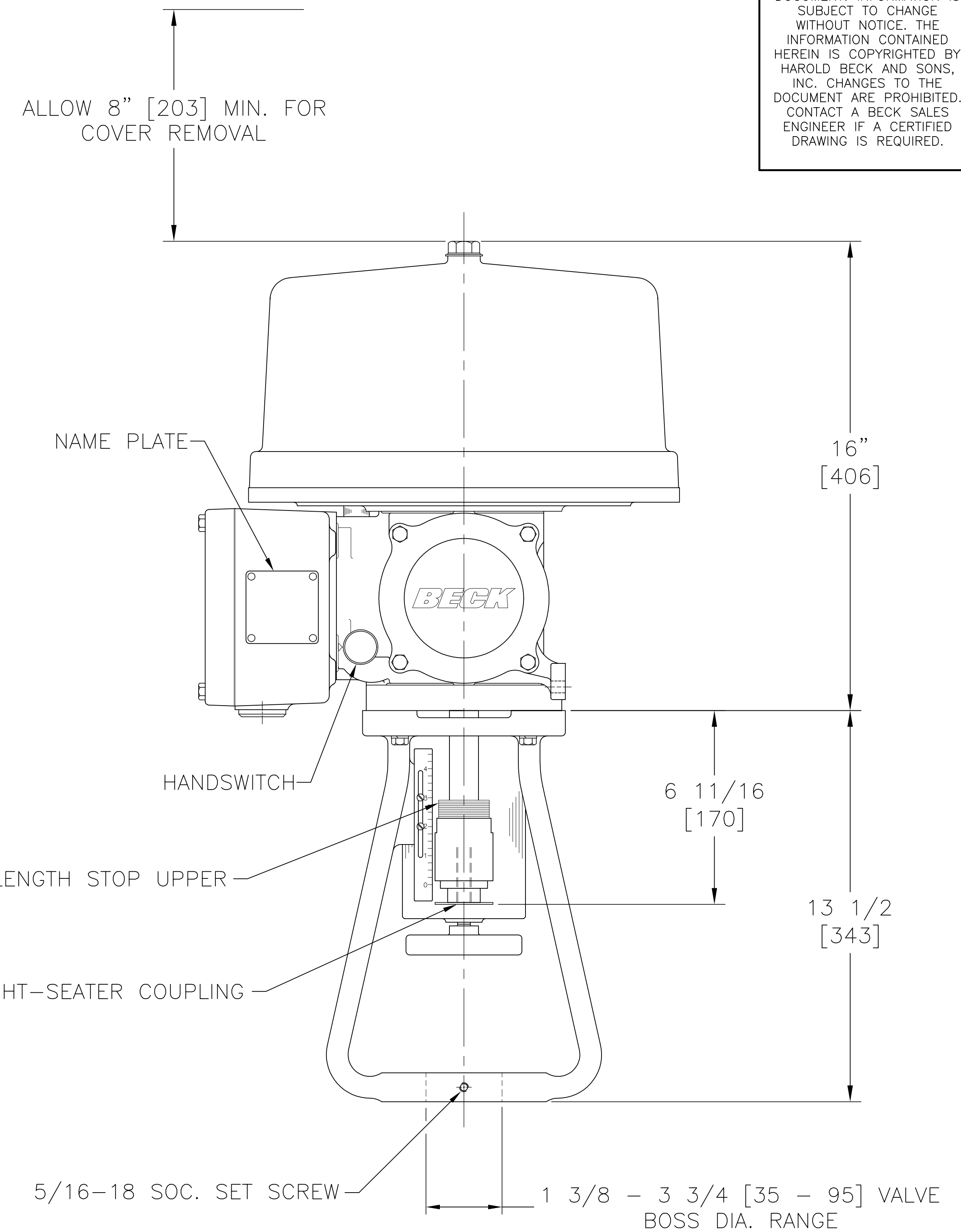
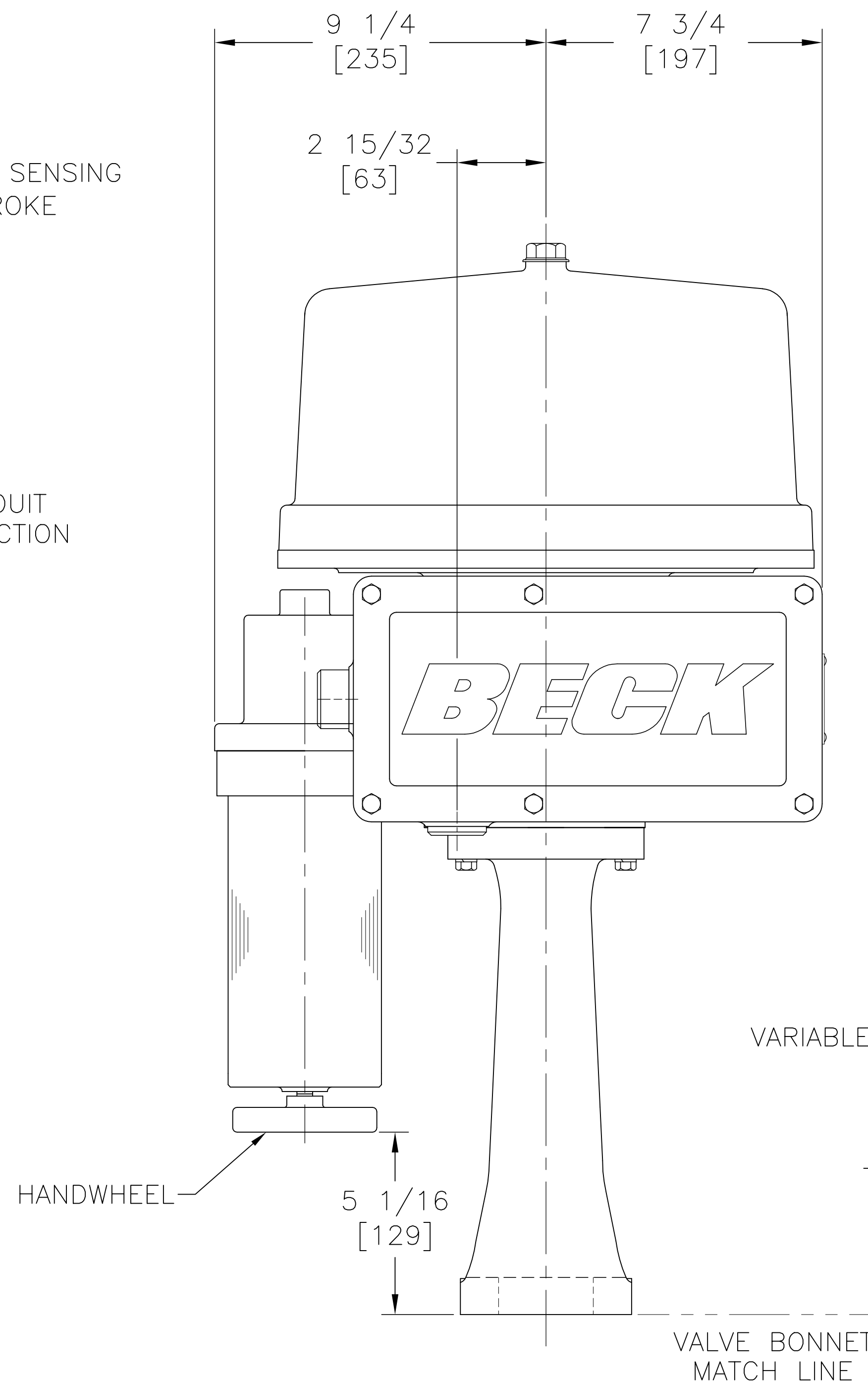
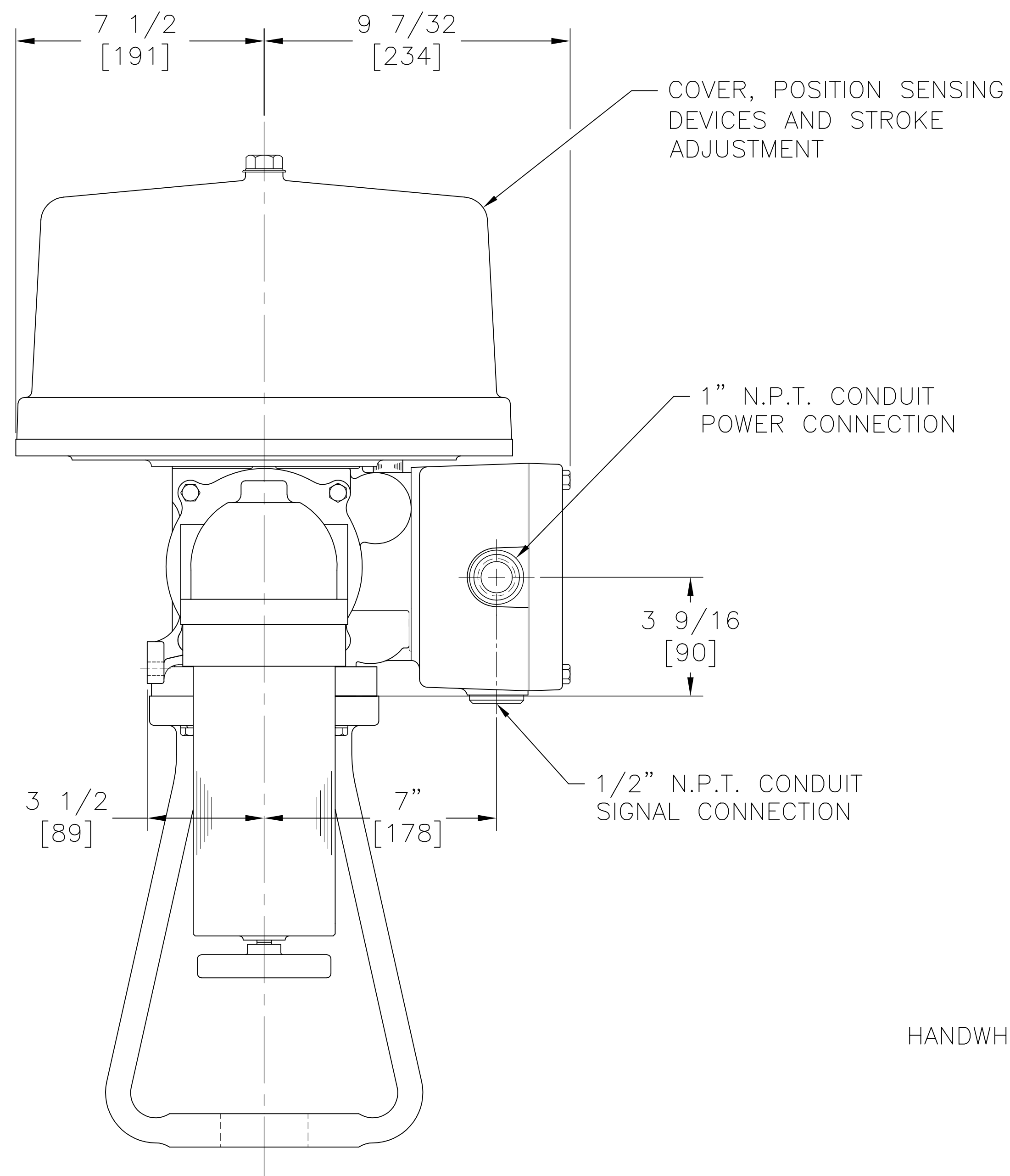

BECK DRIVE MODEL NO.	DRIVE SHAFT TRAVEL RANGE	MAX. VALVE STEM EXTENSION (STEM RETRACTED)	APPROX WEIGHT
<input type="checkbox"/> 14-200	5/16 - 1 3/4 [8 - 44]	9" [229]	105 LBS. 48 KGS.
<input type="checkbox"/> 14-200	3/4 - 2 1/8 [19 - 54]	9" [229]	105 LBS. 48 KGS.

TOLERANCE:
ALL DIMENSIONS ±1/4 [±6]

THE ORIENTATION BETWEEN THE DRIVE AND MOUNTING YOKE MAY BE ROTATED.

ALL DIMENSIONS ARE IN INCHES AND [MM] UNLESS OTHERWISE SPECIFIED.
THREADS AND TAPPED HOLES ARE SPECIFIED AS UNIFIED THREAD SIZES ONLY.
CONDUIT PIPE THREADS PER AMERICAN NATIONAL STANDARD TAPER PIPE THREADS (N.P.T.)

18-0142-010



HAROLD BECK & SONS INC
NEWTOWN INDUSTRIAL COMMONS NEWTOWN, PENNSYLVANIA 18940 USA

TITLE:
OUTLINE DIMENSIONS BECK 14-200 DRIVE
 5/16" TO 2 1/8" [8mm TO 54mm] TRAVEL

DRAWN: GMD 11/8/07	SCALE: NONE	DRAWING NO: 18-0142-010	REV: B
CHECKED: DMS 11/9/07			
APPROVED: JHM 11/12/07		SHEET NO. 1 OF 1	

SIZE: D