

THIS DOCUMENT IS A COPY AND IS NOT THE SOURCE DOCUMENT. INFORMATION IS SUBJECT TO CHANGE WITHOUT NOTICE. THE INFORMATION CONTAINED HEREIN IS COPYRIGHTED BY HAROLD BECK AND SONS, INC. CHANGES TO THE DOCUMENT ARE PROHIBITED. CONTACT A BECK SALES ENGINEER IF A CERTIFIED DRAWING IS REQUIRED.

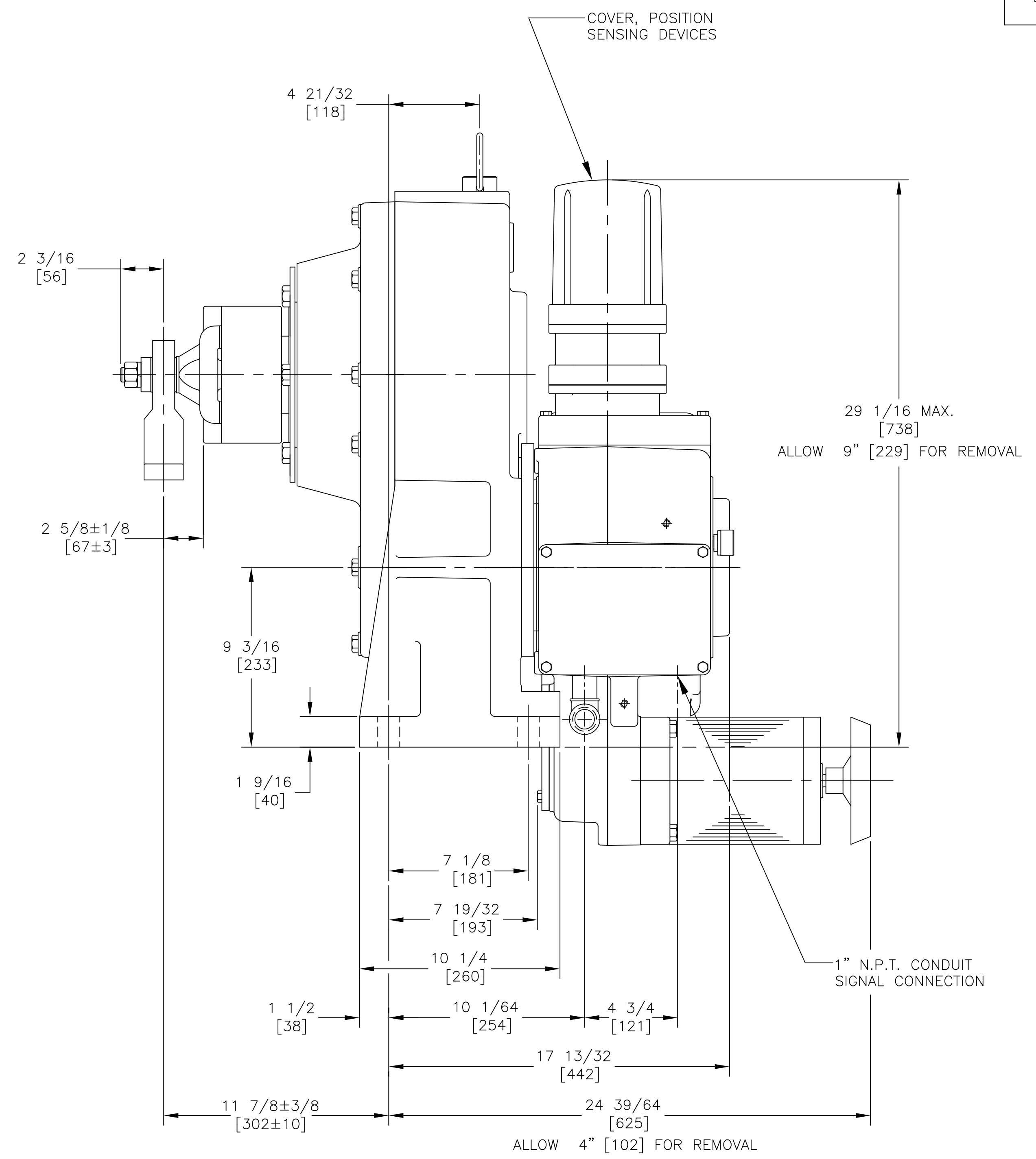
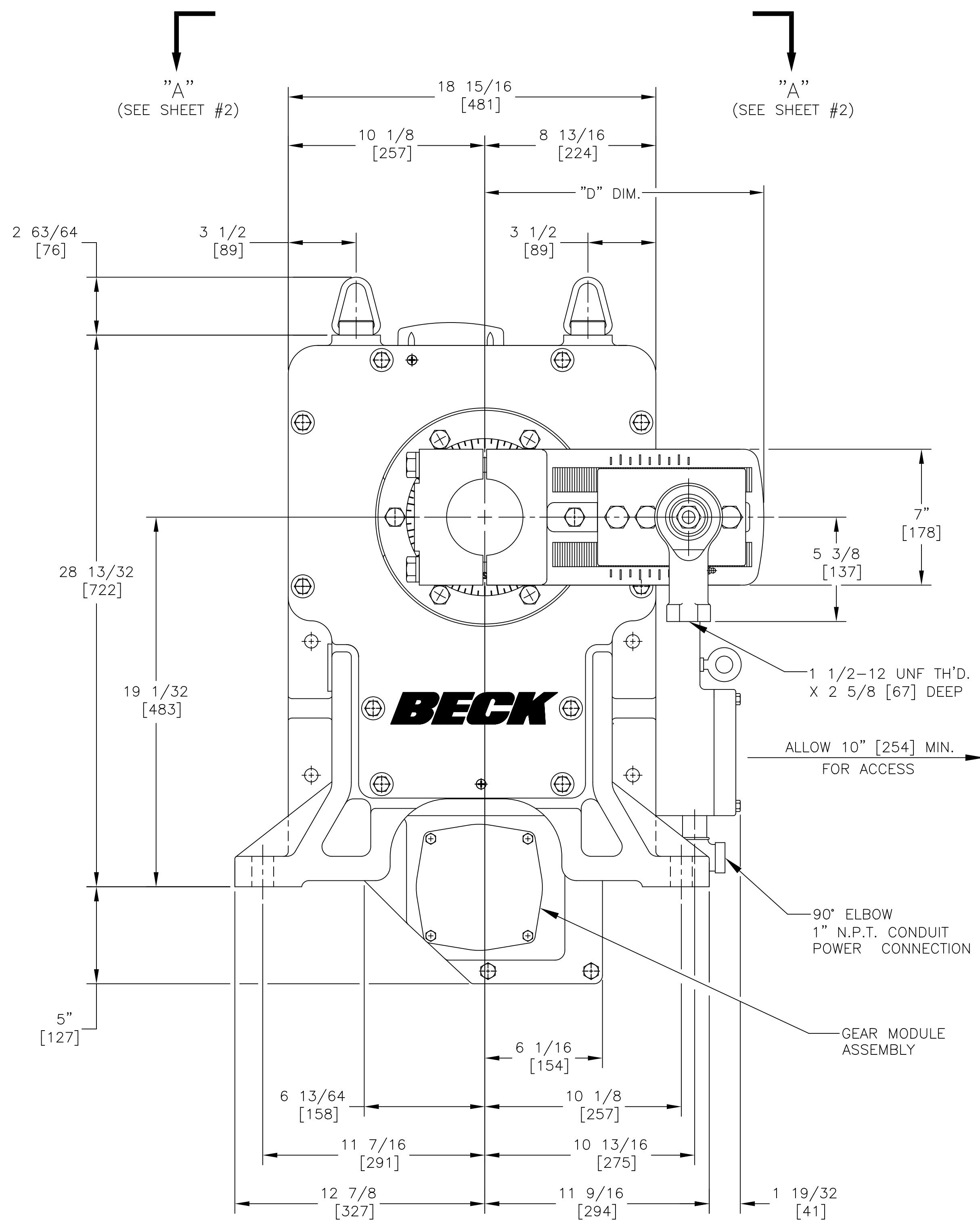

NOTE:
1. BECK DRIVE ROTATION IS ADJUSTABLE BETWEEN 60° AND 100° BY CALIBRATION OF THE ELECTRONIC COMPONENTS.

**ALL DIMENSIONS ARE IN INCHES AND [MM] UNLESS OTHERWISE SPECIFIED.
THREADS AND TAPPED HOLES ARE SPECIFIED AS UNIFIED THREAD SIZES ONLY.
CONDUIT PIPE THREADS PER AMERICAN NATIONAL STANDARD TAPER PIPE THREADS (N.P.T.)**

BECK DRIVE MODEL NO.	TORQUE	APPROX. WEIGHT	OUTPUT SHAFT DIA.	CRANKARM SUPPLIED AS STANDARD			MAXIMUM OVERHUNG LOAD LBS. (KGS.)
				CRANKARM PART NO.	CRANKARM RADIUS (ADJUSTABLE)	CRANKARM LENGTH "D" DIM.	
11-430	2900, 5200 LB.-FT. 3932, 7050 Nm	790 LBS. 358 KGS.	3 15/16 [100]	14-8022-42	6-1/2 TO 10-1/2 [165 TO 267]	14 3/8 [365]	20,000 LBS. (9072 KGS.)
				14-8022-44	9" TO 15" [229 TO 381]	19" [483]	15,000 LBS. (6804 KGS.)

TOLERANCES:
OUTLINE DIMENSIONS ±1/4 [±6]
MOUNTING DIMENSIONS ±1/16 [±2]

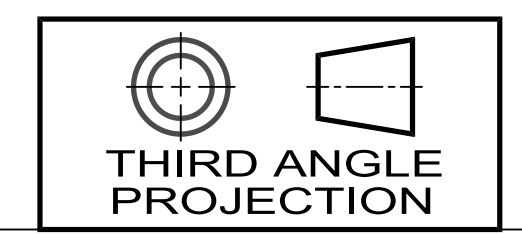

18-0430-01o

HAROLD BECK & SONS INC
NEWTOWN INDUSTRIAL COMMONS NEWTOWN, PENNSYLVANIA 18940 USA

TITLE: **OUTLINE DIMENSIONS BECK 11-430 DRIVE ORIENTATION OPTION "A"**

DRAWN: DWK 10-30-07
CHECKED: DMS 11-6-07
APPROVED: JHM 11-7-07

SCALE: NONE

DRAWING NO: **18-0430-01o**

REV: **J**

SHEET NO. 1 OF 2

SIZE: D