



INSTRUCTION MANUAL

For actuators manufactured
after 10/01/17.



INTRODUCTION

This manual contains the information needed to install, operate, and maintain the Beck 14-100 & 14-200 linear electric actuators, manufactured by Harold Beck & Sons, Inc. of Newtown, Pennsylvania.

The Group 14 actuator is a powerful control package designed to provide precise position control of globe valves and other devices requiring up to 4,000 lbs (17 800 N) of thrust.



NOTICE: This manual includes information that will make installation simple, efficient, and trouble-free. Please read and understand the appropriate sections in this manual before attempting to install or operate the Group 14 actuator.



Group 11 quarter-turn actuators ... are designed specifically for use with ball, plug, and butterfly valves. Direct-coupled, factory-mounted assemblies are available from Beck for easy installation.



Group 11 rotary actuators ... provide precise position control of dampers, quarter-turn valves, fluid couplings, and other devices requiring up to 1,800 lb-ft (2440 N·m) actuator torque.



Group 31 rotary actuators ... are particularly suited for coupling to ball, plug, and butterfly valves up to 4" (102 mm) diameter, and small dampers.

TABLE OF CONTENTS

Product Description	4
General Specifications	5
Outline Dimension Drawings.....	6
Control Options	8
Installation	9
Wiring.....	11
Wiring Options.....	15
Start-up	17
Operation	18
Calibration	
Switches.....	21
Stroke Change	23
Changing Direction of Travel.....	24
Feedback Signal	25
Demand Signal.....	29
Maintenance	
Routine.....	32
Component Replacement	33
Troubleshooting	36
Appendix	
Spare Parts & Components	39
Control Assembly	40
CPS-5 Data.....	44
CPS-5 Functional Block Diagram.....	44
Schematics.....	45
Index	46
Services	47

PRODUCT DESCRIPTION

Beck Group 14 linear actuators are engineered for precise, reliable operation of globe valves requiring up to 4,000 lbs (17 800 N) of thrust. The cool, stable operation of Beck's control motors coupled with the powerful gear train provide the tight, responsive control required by modern control loops to keep operating costs low. The motor can withstand occasional accidental stalls of up to four days without failure, and will resume instant response to control signals immediately upon removal of the condition. Mechanical stops on the output shaft prevent over-travel.

An easy-to-turn, spoke-free Handwheel is incorporated into the Group 14 design to allow manual operation during installation or power outages. The Handwheel can be used to open and close valves smoothly and easily under full load conditions.

The Beck Tight-Seater™ coupling is a part of the Group 14 actuator. This preloaded disk coupling is mounted on the actuator output shaft and provides positive seating of the valve plug up to the rated thrust of the drive. It eliminates high-pressure leakage, which can cause erosion of the valve seat. A patented self-locking mechanism holds the actuator output shaft in position when the motor is deenergized.

A Calibar index allows simple, single-point adjustment of the length of the stroke to match valve requirements. When this adjustment is made, the position feedback signal, end-of-travel limit switches, and any auxiliary switches are all automatically adapted to the new stroke setting.

Valves may also be operated at their individual locations with a built-in electric Handswitch.

Beck's ESR-5 Electronic Signal Receiver provides precise actuator control from either conventional analog or computer-based control systems.

Beck's CPS-5 Contactless Position Sensor provides accurate position feedback in demanding environmental conditions, with no contacting or wiping surfaces to wear or intermittently lose contact.

Beck Group 14 electric actuators are designed with individual weatherproof enclosures to protect the main components.

Although the Group 14 actuator is normally installed in the upright position, the actuators may be installed in any orientation. For installations where the piping will not support the weight of the actuator, holes are provided for mounting hardware.

TYPICAL APPLICATIONS

Beck Group 14 electric actuators are suitable for steam flow control, combustion gas control, and any other application that requires precise valve position control. An actuator may be applied to any globe, cage, or diaphragm valve with a rising stem that has a stroke within the capability of the actuator. An integral mounting yoke is part of each actuator.

Beck Group 14 actuators are available in stroke ranges from 5/16" (7.9 mm) to 4 1/2" (114.3 mm), and in a variety of thrust and timing combinations. See Table 1 for thrust and timing options.

**TABLE 1:
GROUP 14 MECHANICAL AND ELECTRICAL SPECIFICATIONS**

Basic Model	Thrust (lbs. / N)	Timing -- sec./in. (sec./cm.)				Dimensional Data
		@ 60 Hz		@ 50 Hz		
14-100	340 / 1513	4	(1.6)	5	(2)	Pages 6 & 7
	425 / 1891	11	(4.3)	13	(5.1)	
	600 / 2670	16	(6.3)	19	(7.5)	
	650 / 2893	8	(3.1)	10	(3.9)	
	800 / 3560	11	(4.3)	13	(5.1)	
	1,000 / 4450	27	(10.6)	32	(12.6)	
	1,100 / 4895	16	(6.3)	19	(7.5)	
	1,620 / 7209	48	(18.9)	57	(22.4)	
	1,800 / 8010	27	(10.6)	32	(12.6)	
14-200	2,700 / 12015	16	(6.3)	20	(7.9)	
	4,000 / 17800	24	(9.4)	29	(11.4)	

PRODUCT DESCRIPTION *General Specifications*

Input Power	120 V ac single phase 50 or 60 Hz; 48, 72 or 180 watts 240 V ac single phase 50 or 60 Hz		Allowable Tolerance +10%, -15%
	Model	120 V ac	240 V ac
Max. Current and Power	14-100 14-200	.56 A 72 W 1.5 A 180 W	.33 A 80 W .86 A 210 W
Operating Temperature	-40 to 85°C. (-40 to 185°F.) 0 to 100% relative humidity, non-condensing		Feedback Contactless Position Sensor (CPS-5) Feedback Signal 1-5 mA 4-20 mA 10-50 mA 1-5 V dc 0-16 V dc -10 to 10 V dc
Demand Signal Electronic Signal Receiver (ESR-5)	0-5 mA 1-5 mA 4-20 mA 10-50 mA 1-5 V dc -10 to 10 V dc		Output Stability for V ac Input Power 0.25% of span from 102 to 132 V ac
Demand Signal Span Adj.	2 to 18 V dc		Output Stability for Temperature Change $\pm 0.03\%/^{\circ}\text{C.}$ of span for 0 to 50° C. $\pm 0.05\%/^{\circ}\text{C.}$ of span for -40 to 85° C.
Demand Signal Zero Adj.	-100 to 275% of span (except -10 to 10 V dc) Split Signal Range 4-12 mA 12-20 mA		Linearity $\pm 1\%$ of span *
Deadband	0.6% of span		Hysteresis 0.25% of span at any point
Sensitivity	25% of deadband		Isolation Max. leakage of 10 μ A at 60 V rms, 60 Hz from output to ground
Direct AC Control	120 V ac for 2-position, multi- position or modulating V ac control.		Film Potentiometer 1,000 ohms
			Max. Voltage 40 V
			Wattage 2 watts max.
			Linearity $\pm 0.5\%$ *
			Max. Wiper Current 1 mA

* Electrical linearity. Actual feedback relative to output shaft position varies with shaft position up to 15% at the center of stroke range. Consult factory for details.

Action on Loss of Power	Stays in place.
Action on Loss of Input Signal (Power On)	Stays in place or moves to full travel or zero position. actuators to any preset position with optional switch assembly on Models 14-_07 and 14-_08. Field adjustable.
Stall Protection and Annunciation (14-200 standard, 14-100 optional)	If the motor tries to run in one direction for more than 300 seconds, the Stall Protection Module shuts off power to the motor and a solid state relay will change state. The relay is rated for 120 V ac or dc, 10 VA.
Limit Switches	Two SPDT, one for fully retracted and one for fully extended limit of travel (rated 6A, 120 V ac; .5A, 125 V dc; .25A, 250 V dc).
Auxiliary Switches	Up to four switches available (rated 6A, 120 V ac; .5A, 125 V dc; .25A, 250 V dc). Switches are labeled S1 to S4 and are cam operated, field adjustable. S1 and S4 are set to operate just before reaching fully extended travel limit. S2 and S3 are set to operate just before reaching fully retracted travel limit.
Handswitch	Permits local electrical operation, independent of controller signal. Standard on all units. An optional auxiliary contact can be used to indicate that the Handswitch is in AUTO mode. Contact rated at 2.5A, 125 V ac; 2.0A at 28 V dc.
Handwheel	Provides manual operation without electrical power.
Motor	120 V ac, single phase, no burnout, non-coasting motor has instant magnetic braking. Requires no contacts or moving parts. Can remain stalled for 4 days without failure of motor or gearing.
Gear Train	High efficiency, precision cut steel and ductile iron gears and bronze nut. Interchangeable gear modules permit field change of timing.
Mechanical Stops	Prevent overtravel during automatic or manual operation.
Enclosure	Precision machined aluminum alloy castings, painted with corrosion resistant polyurethane paint, provides a rugged, dust-tight and weatherproof enclosure. Type 4; IP66.
Stroke Adjustment	Calibar simultaneously adjusts the stroke length, position feedback signal, limit switches and auxiliary switches. The new stroke displacement is produced by the full demand signal.
Standards*	CSA Labeled (US & Canada); CE Compliant; UKCA Compliant

*NOTE: May not be available with all options and models. For more information, please call Beck at 215-968-4600.

PRODUCT DESCRIPTION Outline Dimensions

OUTLINE DRAWING -- 5/16 [8] to 2 1/8 [54] travel (Dimensions in inches & [mm])

MODEL 14-100

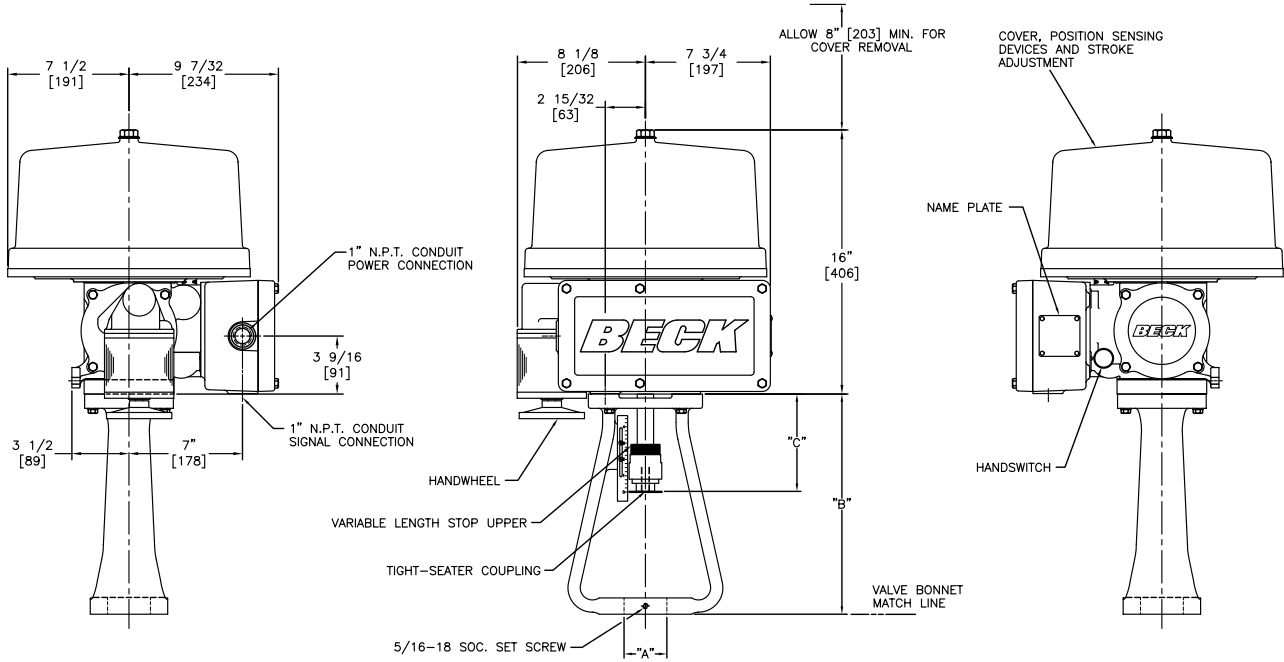

MODEL 14-200

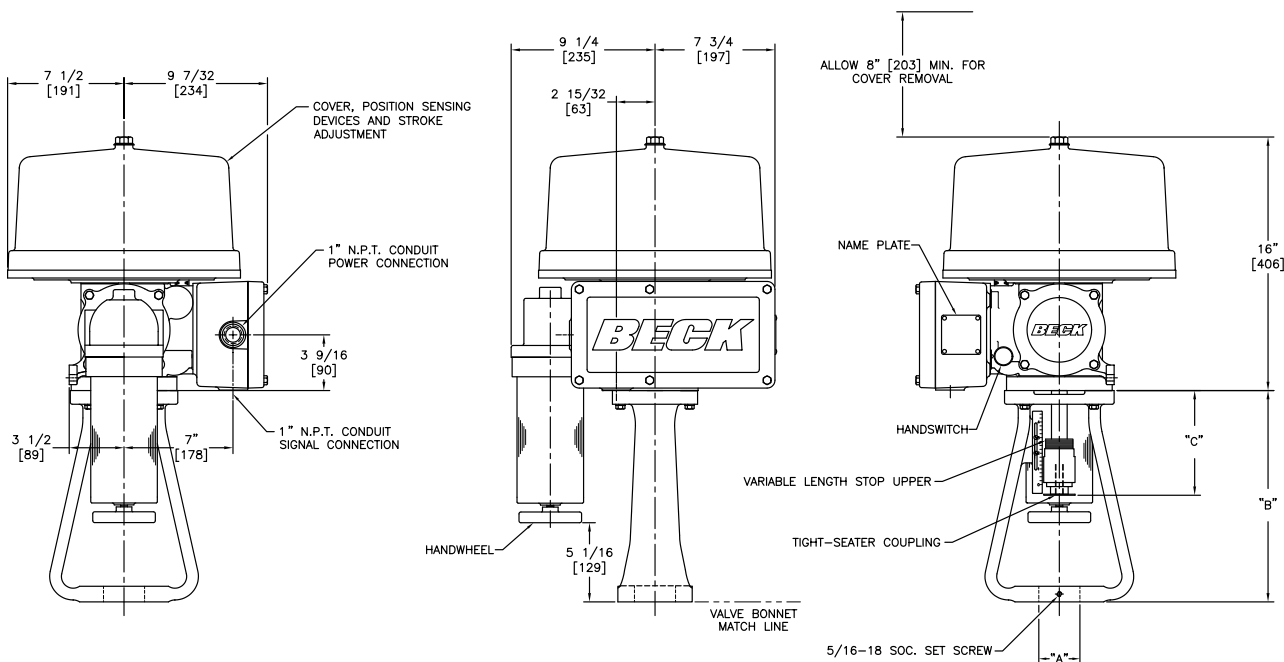

NOTE: Actuators may be mounted in any orientation.

Beck Model 14-100 & -200

Beck Model No.	Drive Shaft Travel Range (in) [mm]	"A" Valve Boss Dia. Range (in) [mm]	"B" Yoke Height (in) [mm]	"C" Nominal Drive Shaft Extension (in) [mm]	Max. Valve Stem Extension (Valve Stem Retracted) (in) [mm]	Approx. Weight (lb) [kg]
14-100	5/16-1 3/4 [8-44]	1-2 5/8 [25-67]	8 [203]	4 3/16 [106]	5 1/2 [140]	80 [36]
	3/4-2 1/8 [19-54]	1 3/8-3 3/4 [35-95]	13 1/2 [343]	6 [152]	9 1/4 [235]	92 [42]
14-200	5/16-1 3/4 [8-44]	1 3/8-3 3/4 [35-95]	13 1/2 [343]	6 11/16 [170]	9 [229]	105 [48]
	3/4-2 1/8 [19-54]					

OUTLINE DRAWING -- 3/4 [19] to 4 1/2 [114] travel (Dimensions in inches & [mm])

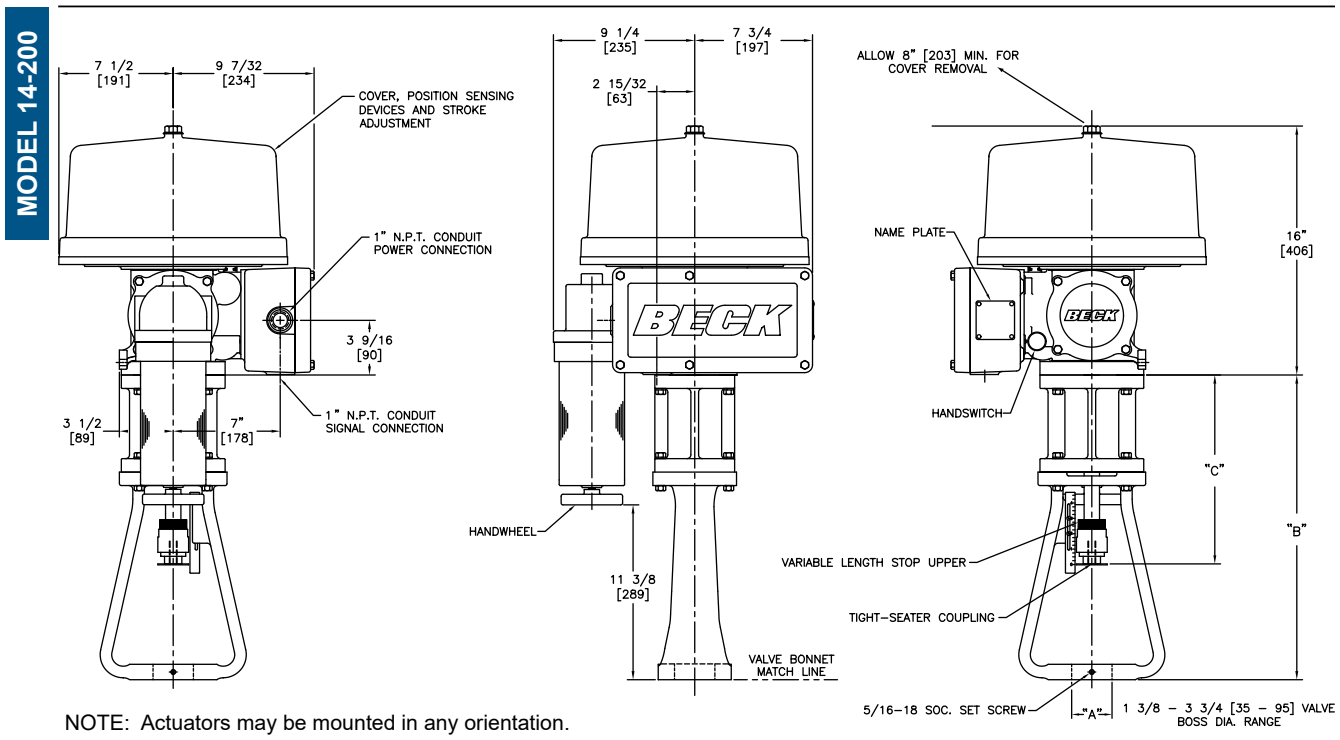
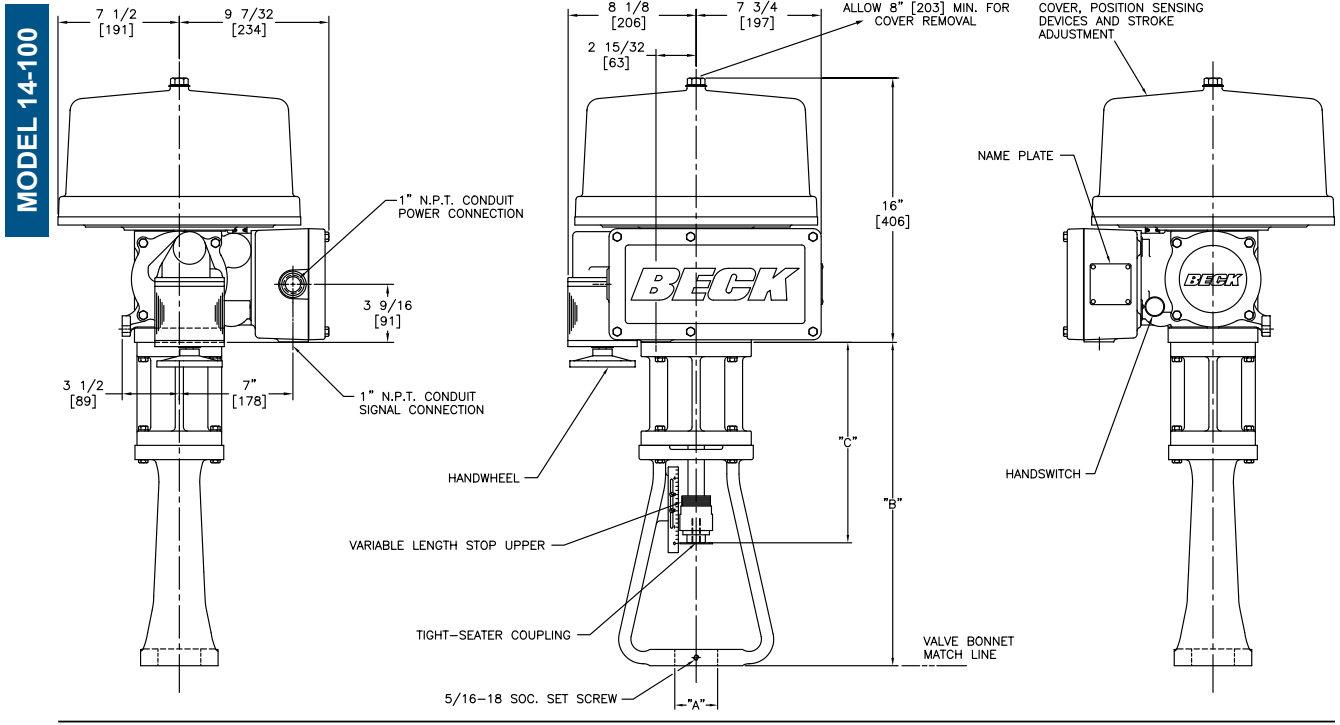

NOTE: Actuators may be mounted in any orientation.

Beck Model 14-100 & -200

Beck Model No.	Drive Shaft Travel Range (in) [mm]	"A" Valve Boss Dia. Range (in) [mm]	"B" Yoke Height (in) [mm]	"C" Nominal Drive Shaft Extension (in) [mm]	Max. Valve Stem Extension (Valve Stem Retracted) (in) [mm]	Approx. Weight (lb) [kg]
14-100	3/4-3 1/2 [19-89]	1 3/8-3 3/4 [35-95]	19 13/16 [503]	12 5/16 [313]	9 1/4 [235]	100 [45]
	1 3/4-4 1/2 [44-114]		19 13/16 [503]	12 5/16 [313]	9 1/4 [235]	100 [45]
14-200	3/4-3 1/2 [19-89]	1 3/8-3 3/4 [35-95]	19 13/16 [503]	13 [330]	9 1/4 [235]	113 [51]
	1 3/4-4 1/2 [44-114]		19 13/16 [503]	13 [330]	9 1/4 [235]	113 [51]

PRODUCT DESCRIPTION *Control Options*

**TABLE 2:
SUMMARY OF GROUP 14 CONTROL OPTIONS**

MODEL NO.	CONTROL TYPE	INPUT SIGNAL	ESR-5 PART NO.*	FEEDBACK DEVICE	EXTERNAL OUTPUT SIGNAL	CPS-5 PART NO.*	AUXILIARY SWITCH OPTIONS
14-__8	Electronic Modulating	0-5 or 1-5 mA	13-2246-02	CPS-5 Contactless Position Sensor (with Monitor)	4-20 mA	20-4400-12	None 2 4 2+INTLOS
		4-20 mA	13-2246-03		1-5 V dc 16 V dc 50 mA max.	20-4400-13	
		10-50 mA	13-2246-04				
		0-10 V dc	13-2246-07				
		1-5 V dc	13-2246-05				
		-10-10 V dc	13-2246-08				
14-__7	Electronic Modulating	0-5 or 1-5 mA	13-2246-02	1000 ohm Potentiometer 20-3060-03	None, 1000 ohm Aux. Pot.	n/a	None 2 4 2+INTLOS
		4-20 mA	13-2246-03				
		10-50 mA	13-2246-04				
		0-10 V dc	13-2246-07				
		1-5 V dc	13-2246-05				
		-10-10 V dc	13-2246-08				
14-__6	Direct AC Control (Modulating)	120 V ac	None	CPS-5 Contactless Position Sensor (without Monitor)	4-20 mA	20-4400-02	None 2 4
		Low Power 120 V ac	13-2246-50 (Relay Board)		1-5 V dc 16 V dc or 50 mA max.	20-4400-03	
		Low Power dc	13-2246-51 (Relay Board)				
14-__5	Direct AC Control (Modulating)	120 V ac	None	1000 ohm Potentiometer 20-3060-03	1000 ohm Pot.	n/a	None 2 4
		Low Power 120 V ac	13-2246-50 (Relay Board)				
		Low Power dc	13-2246-51 (Relay Board)				
14-__4	5 Position	120 V ac	n/a	None	None	n/a	None
	4 Position						None 2
	3 Position						
14-__3	2 Position Open/Close	120 V ac	n/a	None	None	n/a	None 2 4

*ESR-5 series 13-2246-XX boards replace 13-2245-XX series boards, except for the Relay Boards, as noted.
CPS-5 series 20-4400-XX boards replace 20-3400-XX series boards.

INSTALLATION

SAFETY PRECAUTIONS



WARNING

Installation and service instructions are for use by qualified personnel only. To avoid injury and electric shock, do not perform any servicing other than that contained in this manual. Please read and understand the appropriate sections in this manual before attempting to install or operate your actuator.

STORAGE INFORMATION

The actuator should be stored in its shipping carton in a clean, dry area.

If it is necessary to store the actuator outdoors for a long period of time, it should be removed from its shipping carton and stored above ground. A waterproof cover should be securely fastened over it. Do not stack actuators on top of one another. Stored actuators should be periodically checked to make sure no condensation has formed in the control compartments. Damage due to moisture while in storage is not covered by warranty.

UNPACKING

Group 14 actuators are packed in standardized cardboard shipping containers. actuators mounted on valves may be packed in cardboard containers or strapped to a skid and crated, depending on size. After unpacking, the wooden platform may be used to transport the actuator to the installation site.

INSTALLATION—MECHANICAL

Beck actuators can be furnished with valves mounted as unitized assemblies ready for pipeline installation.



CAUTION

Working with valves installed in a pipeline can be dangerous. Take appropriate precautions when mounting to installed valves.

Mounting the Actuator on a Valve

Refer to Figure 1, below, to identify the mounting parts and the steps to install the actuator onto the valve.

1. Prepare the valve. It may be necessary to remove parts that are no longer used or to replace or adjust packing. Refer to the valve maintenance manual for specific instructions. Consult the Beck Valve Mounting Specification sheet that was shipped with the actuator for any instructions regarding modifications to the valve stem that may be necessary.
2. Push the valve stem (11) into the valve body to the fully seated or stem down position.
3. Move the G-14 output shaft (5) up into the actuator body until the upper mechanical stop (3) is tight against the lower bearing plate (1).
4. Remove the four lower bearing plate bolts (2) that hold the bottom plate to the actuator body (1/2" bolt heads). Pressure from the mechanical stop will hold the plate in place when the bolts are removed. Bolt the yoke (9) to the lower bearing plate using the longer bolts supplied with the yoke. Torque bolts to 10 lb-ft (14 N•m).

Continued

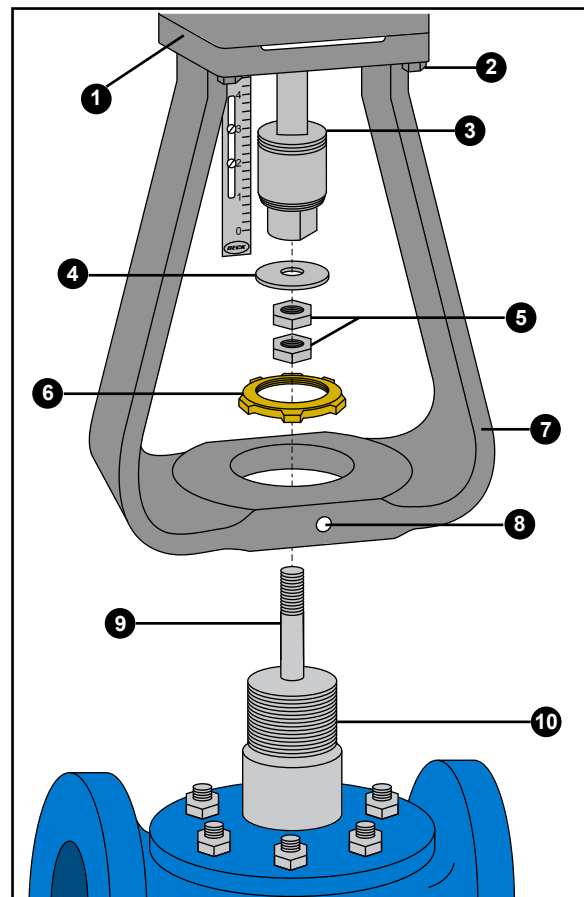

Figure 1

INSTALLATION

MOUNTING THE ACTUATOR, CONT'D.

- Place the jam nut (7) and travel index (6) over the valve stem (11) before mounting the actuator on the valve.
- Remove the boss nut (8) from the valve and place the actuator and yoke over the stem and onto the boss (12). Secure the yoke with the boss nut, finger-tight.
- Using the actuator Handwheel, lower the actuator output shaft to contact the valve stem. Thread the valve stem into the end of the actuator output shaft. HINT: Rotate the whole yoke /drive assembly to get the valve stem started into the actuator output shaft. Continue lowering the actuator output shaft and threading the valve stem until the actuator output shaft is fully down on the mechanical stop.
- Tighten the boss nut to secure the yoke and tighten the yoke set screw (10).
- Follow the valve seating adjustment procedure on page 17 to complete the mounting.

Removing the Actuator from a Valve

- Move the Group 14 output shaft up into the actuator body until the mechanical stop (3) is tight against the lower bearing plate (1).
- Turn off all electrical power and disconnect all electrical wiring from the drive.
- Loosen the valve stem jam nut (7). Loosen the boss nut (8) on the yoke and leave it finger tight. Loosen the yoke set screw (10).
- Unthread the valve stem from the actuator output shaft by turning the whole yoke / actuator assembly.

Valve Installation

The Beck control actuator can be mounted in any convenient orientation. There is no preferred operating position.

Inspect the valve body to be sure that it is clean. Be certain that other pipelines in the area are free from pipe scale or welding slag that could damage the gasket surfaces.

Tighten the flange bolts and ensure that all bolts are evenly torqued. Refer to the gasket manufacturer's instructions for specific information on tightening flange bolts.

NOTE: The valve may have experienced temperature variations in shipment. This could result in seepage past the stem seals. Refer to the valve manufacturer's maintenance instructions for packing adjustments.

INSTALLATION—ELECTRICAL

Two conduit connections are provided in every Beck Group 14 actuator for supplying power and signal wiring to the unit. Temporary plugs are installed in the conduit entrances at the factory for shipping only and are not intended for permanent use.

Conduits should be routed from below the actuator so that condensation and other contaminants flow away from the conduit. Prior to actuator operation, all conduit entrances must be properly sealed in accordance with National Standards or Regulatory Authorities.

To maintain signal integrity and meet most electrical codes, power and signal wires must be routed to the actuator separately. The signal wiring should be either shielded cables or be installed in conductive conduit and/or cable trays.

A large, clearly labeled terminal block on the side of the actuator is enclosed in a gasketed metal enclosure. Terminals will accommodate up to 12 AWG (3.31 mm²) wiring (see Figure 2, page 11).



CAUTION

Always close covers immediately after installation or service to prevent moisture or other foreign matter from entering the actuator.

Refer to the wiring diagram furnished with your Beck actuator for proper AC power and signal connections. It is advisable to provide normal short circuit protection on the AC power line. A copy of the wiring diagram is shipped with each actuator and is fastened to the inside of the terminal block cover. If there is no wiring diagram available, you may obtain a copy from Beck by providing the serial number of your drive.

Your Beck actuator has been supplied to match the signal source in your control loop. If it does not match, refer to the Demand Signal Options section of this manual, page 15, for information on how to change the demand signal.

For maximum safety, the Beck actuator body should be grounded. Normally, the electrical conduit provides adequate ground protection. If not, a separate ground conductor should be connected to the actuator body.

INSTALLATION Wiring

The Group 14 actuator is available with six separate control configurations which are provided to match the control requirements for your system. Typical functional wiring connections for each control option are described in the following paragraphs and diagrams. The wiring diagram specific to each actuator is attached to the inside of the wiring terminal cover.

Feedback connections for actuators incorporating the Contactless Position Sensor (CPS-5) for control options 6 and 8 are described on pages 13 and 14.

A Group 14 actuator can be ordered with up to four optional auxiliary switches. Wiring connections for these are described on page 22.

To enable full Handswitch operation, connect a 120 V ac line to terminal C (jumper between terminals A and C).

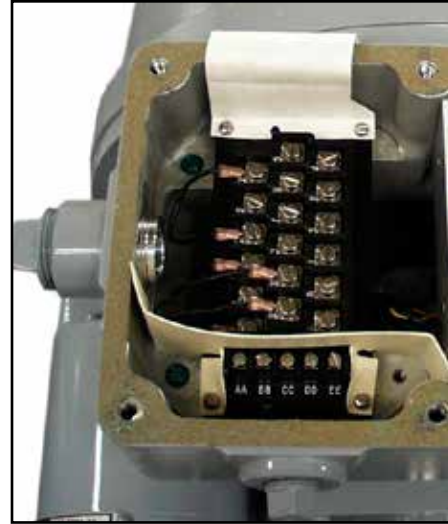
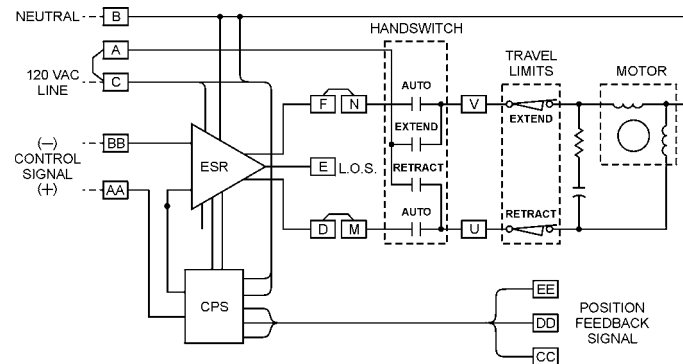

Figure 2

Option 8, Modulating Analog Position Control with Contactless Position Sensing

Customer must supply two wires to power the drive: One 120 V ac line (terminal C), and one neutral (terminal B). Customer must supply two wires for the modulating analog control signal: Connect to terminal AA (+) and to terminal BB(-). Customer may supply two additional wires to monitor the analog position feedback signal (see pages 13 and 14 for connections). The actuator's feedback circuit power supply is derived from the 120 V ac line, therefore the feedback signal must be wired to a "4-wire" type non-powered analog input.



The wiring diagram at right is a typical example of an Option 8 actuator with a Stall Protection Module installed.

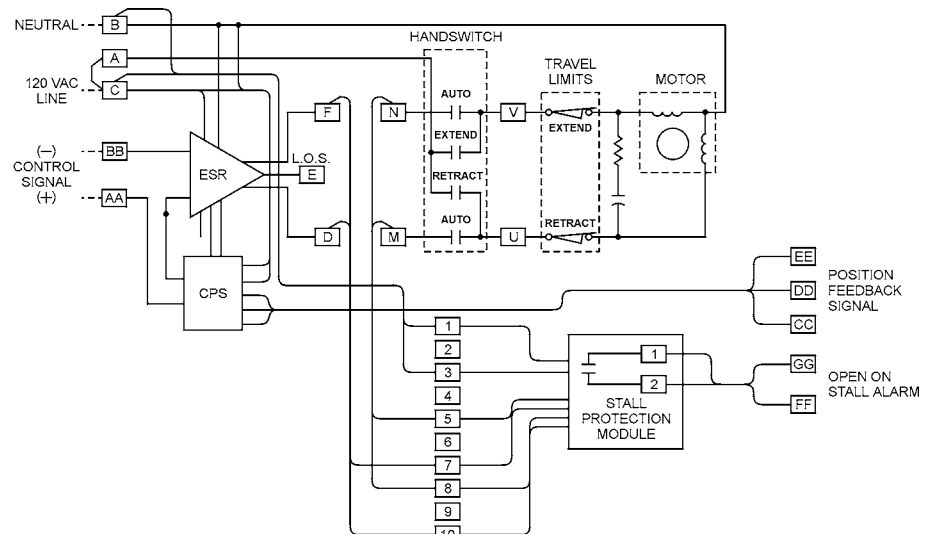

INSTALLATION Wiring

Option 8, Modulating without External Feedback Signal

Analog Position Control with Contactless Position Sensing

Customer must supply two wires to power the drive: One 120 V ac line (terminal C), and one neutral (terminal B). Customer must supply two wires for the modulating analog control signal: Connect to terminal AA (+) and to terminal BB(-).

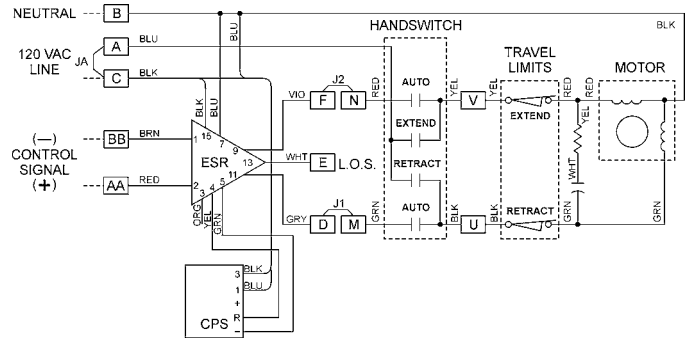

Option 7, Modulating

Analog Position Control with Potentiometer Position Sensing

Customer must supply two wires to power the drive: One 120 V ac line (terminal C), and one neutral (terminal B). Customer must supply two wires for the modulating analog control signal: Connect to terminal AA (+) and to terminal BB (-). If position feedback monitoring is required, an optional auxiliary potentiometer can be ordered. The optional auxiliary potentiometer connects to terminals CC (Reverse), DD (Wiper), and EE (Forward) and is compatible with standard "slidewire" style inputs.

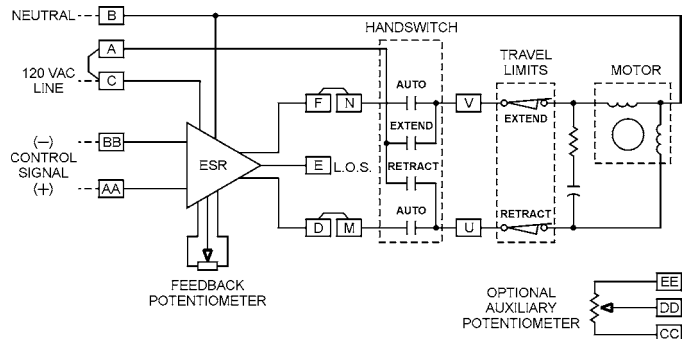

Option 6, Modulating

Direct AC Control with Contactless Position Sensing

Customer must supply three wires to directly control the actuator motor direction: One 120 V ac line for Retraction (terminal M), one 120 V ac line for Extension (terminal N), and one neutral (terminal B). Customer may supply two additional wires to monitor the analog position feedback signal (see pages 13 and 14 for connections). If position feedback monitoring is desired, a 120 V ac line must be connected to terminal C. The actuator's feedback circuit power supply is derived from this 120 V ac line, so the feedback signal must be wired to a "4-wire" type, non-powered analog input.

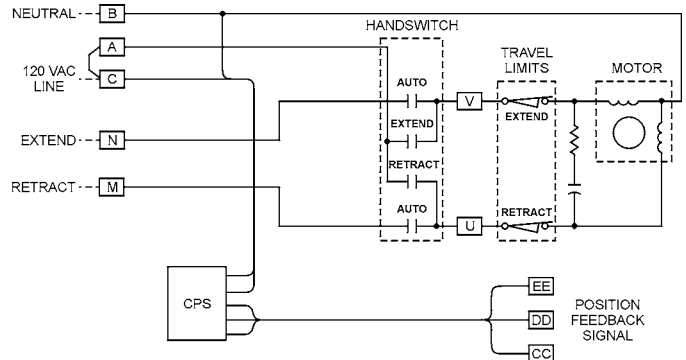

Option 5, Modulating

Direct AC Control with Potentiometer Position Sensing

Customer must supply three wires to directly control the actuator motor direction: One 120 V ac line for Retraction (terminal M), one 120 V ac line for Extension (terminal N), and one neutral (terminal B). The position feedback potentiometer connections are available at terminals CC (Reverse), DD (Wiper), and EE (Forward).

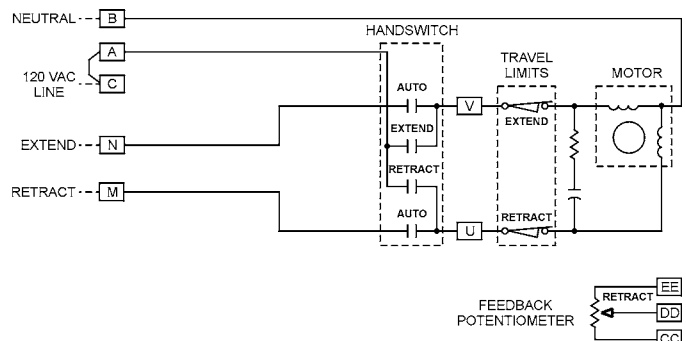

Option 4, Multi-Position

Direct AC Control with Cam-Operated Switches to Stop actuator Travel

Customer must supply three wires to directly control the actuator motor direction: One 120 V ac line for Retraction (terminal M), one 120 V ac line for Extension (terminal N), and one neutral (terminal B). Up to five intermediate stop positions may be specified, each requiring an additional 120 V ac line.

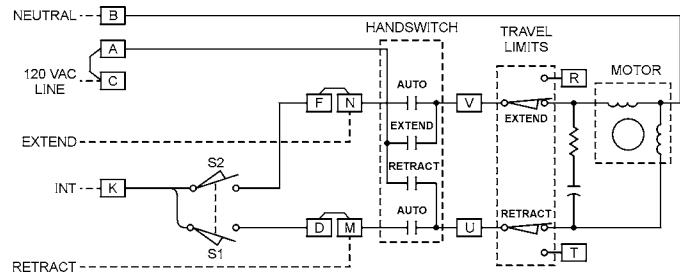

Option 3, Open / Close

Direct AC Control

Customer must supply three wires to directly control the actuator motor direction: One 120 V ac line for Retraction (terminal M), one 120 V ac line for Extension (terminal N), and one neutral (terminal B).

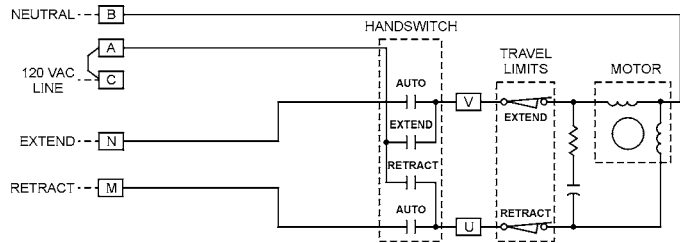

240 V ac Operation

All of the options described above are available for 240 V ac operation instead of 120 V ac operation. In all cases, the power neutral is

replaced with Line 2 of the 240 V ac, and the 120 V ac line is replaced with Line 1 of the 240 V ac.

CPS-5 SIGNAL CONNECTIONS

Beck Group 14 actuators equipped with the Contactless Position Sensor (CPS-5) are shipped ready for installation. They are engineered to match the mA or V dc feedback range in your system.

Customer connections for feedback signal wiring on each CPS-5 model are described in the following diagrams and paragraphs. Refer to Table 11, page 44, for output signal ranges, output terminals, range changing resistance values, and terminals to which the ranging resistor or jumper is connected.

To verify that the feedback signal range is correct for your drive, connect a mA / V dc multimeter across the appropriate terminals (check model number on CPS-5 transformer and Table 11, page 44, for correct terminals CC, DD, or EE). Use the Handswitch to operate the actuator throughout its full travel.

NOTE: Ranging resistors must be connected to the control actuator output terminals. If a ranging resistor change is required, it may be obtained locally. If resistors with $\pm 1\%$ tolerance are not available, they can be ordered from Beck.

CPS-5 Model 20-4400-02, -12 Terminal Connections

1. A single 4–20 mA current output is available between terminals EE (+) and CC (-) when driving into an external load between 250 and 800 ohms. No ranging resistor is required.
2. 4–20 mA output is also available across EE (+) and DD (-); 500 ohms is the maximum external load (for larger loads see Item 1 above).

4-20 mA Signal Output

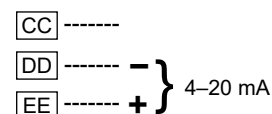
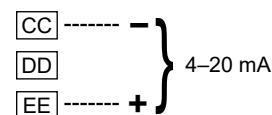

INSTALLATION Wiring

CPS-5 Model 20-4400-03, -13

Current Feedback

Terminal Connections

The universal model has current sensing terminals, which allow for various current signal ranges. Current output is available between terminals DD (+) and CC (-) with the proper ranging resistor connected across terminals DD and EE.

Units are factory-calibrated for specified signal ranges and are provided with proper resistors installed.

The ranging resistor value is given in Table 10, page 44, or can be calculated using the following equation:

$$R = \frac{4}{(I - .004)} \Omega$$

Where R = Resistor (Ohms) Connected from DD to EE

I = Output Current Span (Amp)

If converting to a zero-based range (a range that includes zero as an end point), refer to "Adjusting the Zero Potentiometer" section, page 27.

Current Output

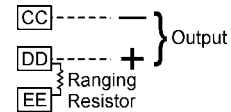

CPS-5 Model 20-4400-03, -13

Voltage Feedback

Terminal Connections

The universal model has a voltage divider network which allows for various voltage signal ranges. Voltage output ranges are available across terminals EE (+) and CC (-) with the proper ranging resistor connected across terminals CC and DD.

Units are factory-calibrated for specified signal ranges and are provided with proper ranging resistors installed. Other voltage ranges are attainable by adding a ranging resistor across terminals CC and DD.

The ranging resistor value is given in Table 11, page 44, or can be calculated using the equation:

$$R = \left(\frac{V}{4} - 1 \right) K \Omega$$

Where R = Resistor connected from CC to DD

V = Output voltage span

If converting to a zero-based range (a range that includes zero as an end point), refer to "Adjusting the Zero Potentiometer" Section, page 27.

Voltage Output

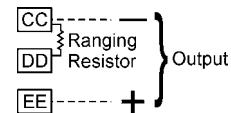

INSTALLATION Wiring Options

DEMAND SIGNAL OPTIONS

Beck Group 14 actuators configured for milliamp or dc analog modulating applications include an Electronic Signal Receiver (ESR-5). Several control options are available with the ESR-5, such as operating more than one actuator with a single signal source.

The instructions below apply to applications that require a signal change or to situations calling for operation of multiple actuators from a common demand signal.

Demand Signal Range Change

If it is necessary to change the range of an ESR-5 board to receive a different demand signal current, the "R-in" resistor must be changed. See Table 3, below, for the proper value, and Figure 11 on page 31 for its location on the board. It is mounted on turrets to facilitate the change. After soldering the new resistor in place, recalibrate in accordance with the instructions on page 29. If a proper resistor with $\pm 1\%$ tolerance cannot be obtained locally, it can be ordered from Beck.

Series Operation

Beck actuators can be connected in series from the same signal for concurrent operation. Care must be taken to keep the polarity correct in each actuator's input terminals. Two or three actuators may usually be connected in series.

The number of actuators that may be connected in series is limited only by the controller's (signal source) capability to feed current into the total resistance of the circuit involved. Consult the controller manufacturer's recommendations.

No change is required to the actuator's calibration for series operation. An interruption in the circuit will actuate loss of demand signal (L.O.S.) on the actuators in the circuit.

Parallel Operation

Beck actuators can be connected in parallel to the same Demand signal for concurrent operation. Up to four actuators may be connected in parallel.

For parallel operation on a 4–20 mA Demand signal, use ESR-5 board no. 13-2246-05 in each actuator and add a resistor across input terminals AA and BB on one of the Beck actuators. The resistor value* should be as follows:

2 actuators = 261 Ω resistor

3 actuators = 270 Ω resistor

4 actuators = 280 Ω resistor

*Resistor values will vary for other Demand signals, please consult the factory.

Note that a minor span adjustment is required for each actuator in parallel. An interruption in the circuit to one actuator will not prevent the other actuators from functioning, but there will be a slight calibration shift.

TABLE 3
ESR-5 MODELS*

INPUT SIGNAL	ESR-5 PART NO.	CHANGE FROM 13-2246-03	EFFECTIVE ESR-5 R-IN (Ω)
1–5 mA	13-2246-02	Remove J10	1 K
4–20 mA**	13-2246-03	None	250
10–50 mA	13-2246-04	Remove J11, add Rin4 (100 Ω)	100
1–5 V dc**	13-2246-05	Remove J9	10 K
0–10 V dc	13-2246-07	Remove J1 and J9	10 K
-10–10 V dc	13-2246-08	Remove J1,J2,J7,J8,J9 and R34	50.0 K

SPECIAL DEADBANDS MODEL					
INPUT SIGNAL	ESR-5 PART NO.	CHANGE FROM 13-2246-03			DEADBAND %
		J3	R42 (M Ω)	RESISTOR PART NO.	
4–20 mA	13-2246-99	REMOVED	4.99	13-2512-12	1
	13-2246-99	Consult factory for other available options			

SPECIAL INPUT RANGE MODEL	
ESR-5 PART NO.	
13-2246-97	Consult factory for available options

SPECIAL LOS FUNCTIONS MODEL	
ESR-5 PART NO.	
13-2246-98	Consult factory for available options

*ESR-5 series 13-2246-XX boards replace 13-2245-XX series boards.

**Standard ISA range (ANSI/ISA-50.1-1982 (R1992))

INSTALLATION *Wiring Options*

Split Range Operation

Two or three Beck actuators may be operated over their full range by a portion of the controller's output signal range. The most common arrangement involves the parallel operation of two actuators operating on equal halves of the Demand signal range. See the following example:

If a 4–20 mA control signal is used, the first actuator would move 100% of its stroke on a signal range of 4–12 mA, while the second operates on the 12–20 mA portion of the signal. In this case, the ESR-5 boards are the same as would be used for parallel operation (13-2246-05), but calibrated to the range required for each actuator. A resistor must be added across input terminals AA and BB on one of the Beck actuators to produce a span between 2 and 6 volts across each board for its active portion of the range; for this example, use a 487 Ω resistor.*

Follow the steps for calibrating the Demand signal, page 29, for each actuator unit, using half span values for the Demand signal. Use the proper starting point for each half-range when setting the zero; 4 mA and 12 mA. Before setting the zero on the second actuator (12 mA), cut R35. See the figure on page 31 for its location on the board.

When three actuators are to be operated on equal portions of the Demand signal, the 4–20 mA range would split into 4–9.33 mA, 9.33–14.67 mA, and 14.67–20 mA signals. A 487 Ω resistor* may be used. Proceed as in the case of the 2-way split, first setting the span, then the zero. When setting the ESR-5 board in the first actuator, set the zero at 4 mA. Then, on the second actuator cut R35 and set its zero at 9.33 mA. Before setting zero in the board of the third actuator, short out R34 by adding a jumper, adjust its zero at 14.67 mA, cut resistors R35 & R36, then remove the jumper from R34. Check operation of all actuators by running the Demand signal through its complete range.

In a split range configuration, connect terminals E and F (L.O.S. wire) to prevent undesired "stay-in-place" operation of the second and, if applicable, third actuator due to fast downward signal changes.

*Resistor values will vary for other Demand signals, please consult the factory.

INSTALLATION Start-Up

START-UP INSTRUCTIONS

After the actuator is mounted and its wiring connections are made, it is ready to be tested for proper operation.

Turn on the power supply. Operate the actuator with the Handswitch and run it through its full stroke, both directions. Observe that the driven device travels through its desired stroke. If satisfactory, set Handswitch at the "auto" position.

If the actuator is to be operated with automatic control, turn on the controller and operate the actuator by varying the control signal. Check that the valve strokes in the proper direction for a change in control signal. An increasing control signal retracts the shaft and opens the valve. With a 100% signal, the actuator is fully retracted. If the valve does not stroke in the proper direction, first check for proper wiring connections and verify the control signal at the drive. If the wiring is correct, then reverse the direction of travel (see page 24).

If the actuator is to be push-button actuated, (options 3, 4, 5 or 6) operate the actuator using the Handswitch and observe that direction of travel is correct. When travel of the driven device is satisfactory with reference to the control signal or the push-buttons, the unit is ready for operation.

Valve Seating Adjustment

The actuator has a Tight-Seater™ attached to its output shaft. The Tight-Seater™ allows tight seating of the valve plug. It is a pre-loaded coupling that allows the valve plug to seat before the actuator reaches its lower limit. The additional amount of travel compresses the thrust discs inside the Tight-Seater™, causing a controlled amount of thrust to hold the valve plug on its seat when the actuator stem reaches its lower limit. The Tight-Seater™ is factory-set to produce a thrust matched to the valve and should never be disassembled. Control of the amount of valve stem threaded into the Tight-Seater™ may be used to adjust the valve seating.

If readjustment of valve seating is necessary, proceed as follows:

1. With the Handswitch, run the actuator to a position above the 0% or lower limit position.
2. Loosen the lock nut on the valve stem and thread the valve stem into the Tight-Seater™.
3. Run the actuator to the 0% position, using the Handswitch.
4. Thread the valve stem out of the Tight-Seater™ until the plug seats in the valve.

5. Raise the actuator shaft using the Handswitch until the plug is clear of the seat and there is sufficient clearance to make the following adjustment.
6. Thread the valve stem out of the Tight-Seater™ a fraction of a turn according to the valve stem thread as listed (1/32" travel):

Thread	Turn
3/8-24	3/4
7/16-18	5/8
1/2-20	5/8
3/4-16	1/2

7. Tighten the lock nut and index disc on the valve stem.
8. Run the actuator to its lower limit using the Handswitch. The valve stem should stop before the actuator shaft stops.
9. Reposition the travel index.



CAUTION

If the valve stem is threaded directly into the actuator shaft without a Tight-Seater™, the valve stem should be at least 1/4 turn from the seated plug position when the actuator shaft reaches the lower limit. This will prevent damage to the valve stem or seat. Do not attempt to obtain tight shut-off without a Tight-Seater™ as serious valve damage may result.

OPERATION

HOUSING

All models of the Beck Group 14 electric actuator have individual, cast aluminum compartments for the main components: The control motor, wiring terminal board, actuator train, electronic signal receiver, and feedback section. Gasketed covers and sealed shafts make this product ideally suited to outdoor and high-humidity environments.

CONTROL MOTOR

The Beck control motor is a synchronous inductor motor that operates at a constant speed of 72 RPM in synchronism with the line frequency.

Motors are able to reach full speed within 25 milliseconds and stop within 20 milliseconds; actual starting and stopping times will vary with load.

Beck motors have double grease-sealed bearings and require no maintenance for the life of the motor.

DRIVE TRAIN

The Group 14 drive train consists of a control motor, SLM, Handwheel, reduction gears, main gear, and power screw output shaft. The ductile iron main gear and the bronze nut and stainless steel power screw output shaft are common to units of a particular range of thrust and timing. The steel reduction gears are part of the field changeable gear housing assembly. Different combinations of output gear, housing assemblies, and motors determine the actuator's output thrust and timing.

The output shaft travel is limited by mechanical stops. The mechanical stop for the fully extended or lower limit of the output shaft travel is not adjustable. The position of the retracted or upward travel mechanical stop is determined by the number of washers on the output shaft between the Tight-Seater™ and the lower bearing plate. This is factory-set for the amount of travel specified at the time of the order and is generally not changed in the field.

Output shaft travel is determined by the setting of the Calibar. Moving the Calibar block away from the output shaft increases the radius where the ball bearing contacts the sector gear lever. The longer the radius the longer the vertical stroke of the output shaft for the same amount of rotation of the control end shaft. Therefore, the Calibar changes the output shaft travel but makes it unnecessary to change the switch cams, film potentiometer, or CPS-5. Field Calibar adjustment is generally used to shorten the travel. Consult the factory if a longer stroke is required.

SELF-LOCKING MECHANISM (SLM)

An integral part of every Group 14 control motor is the self-locking mechanism. This mechanical device couples the motor to the gear train and transmits full motor torque when rotated in either direction. When the motor is de-energized, it instantaneously locks and holds the output shaft in position.

TIGHT-SEATER™

The Beck Tight-Seater™ assembly is a pre-loaded coupling that is installed between the actuator output shaft and the valve stem. It produces a controlled positive pressure against the valve seat, independent of actuator thrust.

The Tight-Seater™ consists of four parts: A housing attached to the output shaft, linear thrust discs contained in the housing, a flanged coupling attached to the valve stem, and a threaded ring to contain the flanged coupling in the housing and to allow adjustment of the pre-load on linear thrust discs.

The factory pre-load, by a threaded ring, ensures that no relative motion occurs between the flanged coupling and housing during normal valve operation until the pre-load thrust is exceeded in the seated plug position of the valve.

When the seated plug position of the valve is reached, the flanged coupling on the valve stem is stationary, and the output shaft exceeds the pre-load pressure of the Tight-Seater™. When the pre-loaded pressure is exceeded, the housing will compress the linear thrust discs, maintaining a controlled pressure on the valve seat, with the shaft stationary.

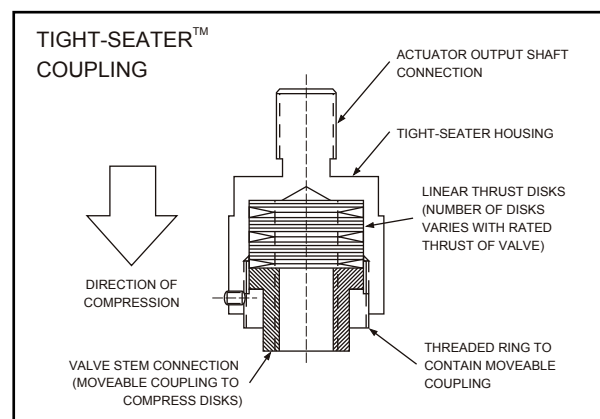

Figure 3



Figure 4: Tight-Seater™

HANDWHEEL

Every Beck Group 14 linear actuator is furnished with a Handwheel for operation of the valve without electrical power. Its solid construction design includes no spokes or projections, and turns at a safe, slow speed. The Handwheel is located at the bottom of the control motor housing. The Handwheel is coupled directly to the motor shaft and rotates when the motor runs. Manual operation of the Handwheel (with electric Handswitch in STOP position) turns the motor and the rest of the actuator train without incorporating a clutch.

HANDSWITCH

A local electric Handswitch is provided on Beck actuators to permit operation at the valve, independent of the controller. As a safety feature, the Handswitch is designed so that the controller can operate the actuator only when it is in the AUTO position. The sequence of the Handswitch is: AUTO, STOP, RETRACT, STOP, EXTEND.

In the AUTO position, two contacts are closed and the ESR-5 or external controller contact completes the control circuit.

In the RETRACT or EXTEND positions, contacts are closed to operate the actuator independently of the controller.

In the STOP position, all contacts remain open.

SWITCHES

Two end-of-travel switches and up to four optional auxiliary switches are provided on Group 14 drives. Switch cams are clamped onto the control shaft, which rotates in relation to the output shaft. Cam position is field-adjustable. Switches are enclosed in high-impact thermoplastic. Switches are rated 6A, 120 V ac; .5A, 125 V dc; .25A, 250 V dc. All auxiliary switch connections are made on the terminal board.

CONTROL OPTIONS

Two basic types of control are available: 120 V ac contact closure (options 3, 4, 5, and 6) and milliamp or dc analog modulating (options 7 and 8). Each option is described below.

Open / close option 3: For simple 2-position control using manual push-buttons or an automatic controller. Preset travel limit switches provide open / close operation upon closure of an automatic controller or manually operated switch. Travel limits are adjustable over the full range of travel and have a repeatability of 0.1°.

Multi-position option 4: Adjustable, cam operated switches provide up to five discrete stop positions upon closure of an automatic controller or manually operated switch. Three, four, and five predetermined position settings are possible, with positioning repeatability of 1° over the range of operation.

Direct ac control option 5: Operated in forward / reverse from a remote location; includes a 1,000 ohm film potentiometer for remote feedback.

Direct ac control option 6: Provides continuous positioning capability over the full range of actuator travel by direct ac from either an automatic controller or manually operated switches. Includes Contactless Position Sensor (CPS-5) for feedback and position indication.

Modulating option 7: For automatic operation in response to milliamp or V dc analog control; includes a film potentiometer for position sensing and feedback to the Electronic Signal Receiver (ESR-5).

Modulating option 8: For automatic operation, as in option 7, above; includes Contactless Position Sensor (CPS-5) for position sensing and feedback to the ESR-5.

OPERATION

INPUT: ELECTRONIC SIGNAL RECEIVER (ESR-5)

Beck modulating actuators are equipped with precision electronic control modules (ESR-5) to receive conventional 4–20 mA or 1–5 V dc control signals directly, eliminating the need for contact protection devices, relays, switches, and reversing starters.

The ESR-5 provides for actuator control with analog control systems, and is designed to operate continuously in temperatures up to 185°F.

A feedback signal from either the CPS-5 or a film potentiometer is compared to the demand signal. The difference between these signals—the error—is amplified and used to actuate either of two electronic motor power switches. These switches drive the motor in the proper direction to force the error to zero. The demand signal is adjustable from 50% to 400% of the 4 volt span, with the zero adjustable from -100 to +275% of span.

The ESR-5 permits two or more Beck actuators to be operated by a single signal source, for series, parallel, or split range operation. See page 15 for details on these control options.

The ESR-5 board requires a feedback signal source. Either the Contactless Position Sensor (CPS-5) or a Film Potentiometer can be provided for this purpose. The CPS-5, with a monitor / isolator board, produces an isolated position feedback signal for the ESR-5 board. The Monitor function monitors the CPS-5 position signal and compares it to established limits. If the output exceeds normal signal conditions, the monitor relay contact opens. This relay may be used for either a remote signal indication or activation of Loss of Signal operation of the drive.

POSITION FEEDBACK: CONTACTLESS POSITION SENSOR (CPS-5)

The CPS-5 provides a continuous feedback signal proportional to the position of the actuator's output shaft. It is used for remote position indication as well as for automatic control loop feedback to the Electronic Signal Receiver (ESR-5). When used with the ESR-5, the CPS-5 includes a monitor / isolator board that delivers an isolated position feedback signal to the Electronic Signal Receiver (ESR-5). The Monitor function monitors the CPS-5 position signal and compares it to established limits. If the output exceeds normal signal conditions, the monitor relay contact opens. This relay may be used for

either a remote signal indication or activation of Loss-of-Signal operation of the drive.

The position sensing function of the CPS-5 is provided by a ferrite magnetic sensing element consisting of two parts: A ferrite stator mounted on the CPS-5 circuit board and a ferrite rotor mounted on the control shaft, driven by the Beck actuator's output shaft through the Calibar assembly. The electronic circuit translates the signal from the ferrite magnetic sensor into an analog position feedback signal designed to interface with electronic control systems and indicating instruments.

POSITION FEEDBACK: FILM POTENTIOMETER

The film potentiometer produces a voltage that is some fraction of the voltage applied across its resistive element. That voltage fraction is determined by the position of the wiper on the resistive element. The potentiometer assembly also includes two fixed resistors, one on each end of the resistive element. These resistors permit suppressed ranges as well as zero-based position feedback voltages. If position feedback is desired on actuators equipped with an ESR-5 board, two film potentiometers are required: One for position feedback and the second to supply a feedback signal to the ESR-5.

LOSS OF CONTROL SIGNAL (L.O.S.)

Beck actuators equipped with the ESR-5 have the ability to move to a predetermined position upon loss of input control signal. When the demand signal drops to 13% of span below the zero setting, the ESR-5 provides an annunciating signal with one of the following options:

1. STALOS = Stay in place, lock in last position (triac output available for remote alarm 0.12 to 5A, 120V, 50 or 60 HZ).
2. REVLOS = Extend to the end-of-travel limit switch position. Connect terminal E to F.
3. FWDLOS = Retract to the end-of-travel limit switch position. Connect terminal E to D.
4. INTLOS = Move to predetermined intermediate auxiliary switch position. Consult factory.

When the demand signal is lost but the power remains on, the L.O.S. switch on the ESR-5 board is energized, a red LED on the board lights and the directional switches are turned off. The output of the L.O.S. switch is connected to terminal E which is wired for one of the predetermined operating modes listed above.

CALIBRATION Switches

SWITCH ADJUSTMENTS

All Group 14 control actuators are shipped with end-of-travel limit switches and all auxiliary switches factory adjusted for 100% of travel unless otherwise specified at time of order. Limit switches must be set inside the range of the built-in mechanical stops to prevent stalling of the motor.

Although the switches may be reset through adjustment of the cam position, it is usually advisable to change the valve travel by using the Calibar index feature described on page 23.

Each switch should open the motor circuit before the mechanical stop is reached. Use the travel index on the output shaft to check the setting. Three percent or more between the mechanical and electrical limits is satisfactory. To check, actuator to the electrical limit using the

Handswitch, and then turn the Handwheel until the mechanical stop is reached.

All switches are SPDT and are rated at 6 A, 120 V ac. Switches are operated by cams which are clamped on to the control shaft. Setting a switch involves loosening the cam, moving the output shaft to the desired position, and positioning the cam so that it just operates the switch at that point. In the following procedure, the use of a continuity meter is recommended to determine when the switch opens or closes. If such a meter is not available, it is possible to hear the switch click as the contacts open and close.



CAUTION

Do not attach the meter or attempt to move the switch cams until the actuator is disconnected from the line voltage and auxiliary switches are disconnected from external power sources.

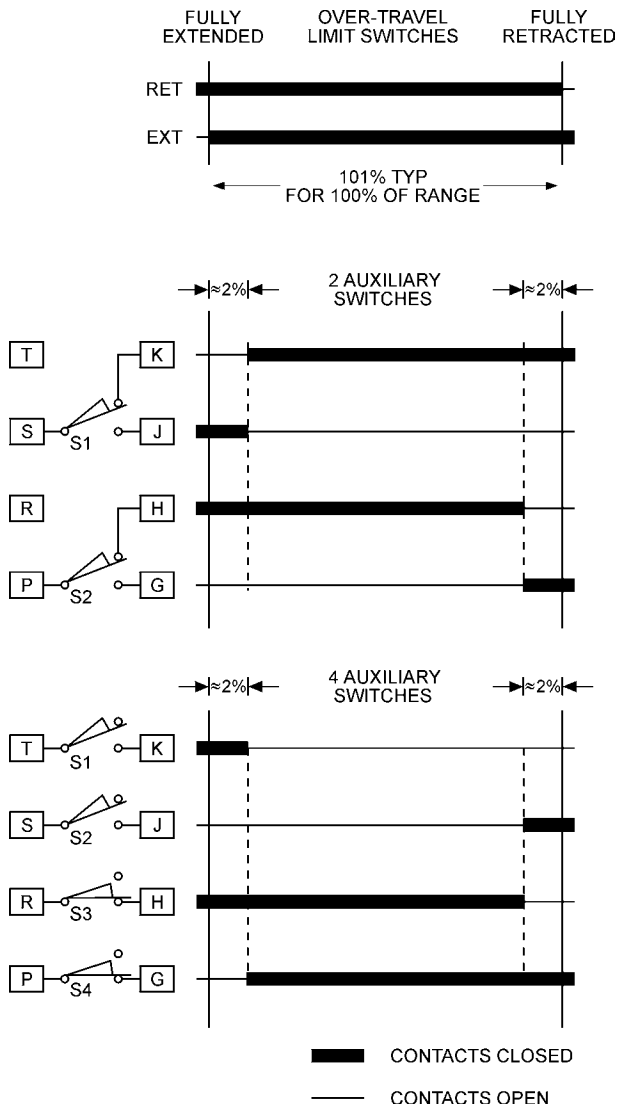

Standard Over-travel Limit and Auxiliary Switch Settings

Setting Travel Limit Switches RET and EXT

This procedure should be used if the factory end of travel switch settings must be changed in the field. It is advisable to operate the actuator fully each direction, using the electric Handswitch to check switch settings before attempting to change them. Follow these instructions if they require adjustment.

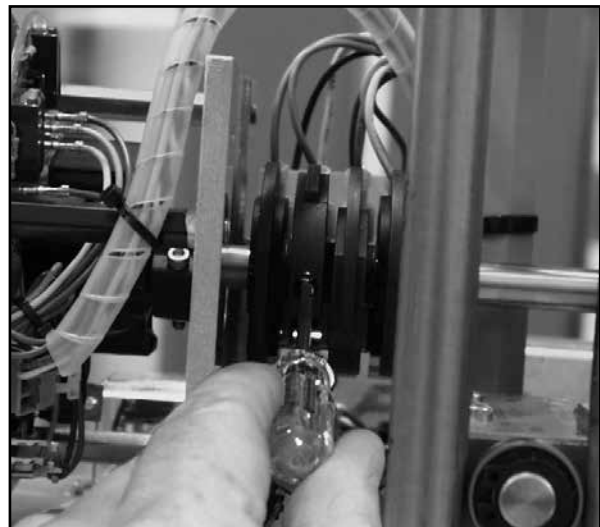

Figure 5

1. Remove the top cover (15/16" bolt head). The O-ring seal will remain in the rim of the top cover when removed. Open the terminal block cover (1/2" bolt head).

Continued

CALIBRATION Switches

SETTING TRAVEL LIMIT SWITCHES, CONT'D.

2. Use the electric Handswitch to drive the control shaft so that the EXT switch cam is accessible. Using a 7/64" hex wrench, loosen the screw so that the cam is just snug to the shaft. See Figure 5, page 21.
3. Use the Handwheel to position the control shaft so that the lever of the sector-lever gear assembly is parallel with the upper bearing plate. See Figure 6, below, for location of lever and bearing plate.



Figure 6

4. Disconnect power from the drive.
5. Connect the continuity meter across terminals B and V. Rotate the cam until the meter shows no continuity (a switch contact opens; switch clicks).
6. Tighten the cam locking screw to 5 lb-in (0.56 N•m) torque.
7. Disconnect the meter and reconnect switch wires and actuator power.
8. Using the Handswitch, drive the output shaft to the fully retracted position. Note the direction of rotation of the lobe of the cam. The correct cam lobe motion is away from the switch lever with the switch lever on the lower part of the cam. If this is not correct, return to step 2 and reset the cam to the proper orientation.
9. Drive the output shaft again to the fully extended travel limit. If the correct stopping point is reached (lever parallel with the upper bearing plate), the switch is properly set.
10. Manually position the control shaft position indicator dial to zero.
11. With the Handswitch, move the control shaft until the position indicator dial reaches the 150° position.
12. Repeat the instructions for setting the RET travel limit except that the direction of motion is opposite to that used for the EXT switch setting. Connect the continuity meter across terminals B and U.

13. Close the covers and tighten the terminal cover bolt to 10 lb-ft (14 N•m). Tighten the top cover bolt just enough to compress the O-ring seal.

Setting Auxiliary Switches

Standard switch settings for actuators with 2 or 4 auxiliary switches are shown on the diagram on page 21. The operating point of all auxiliary switches is defined as a percentage of output shaft travel. 100% is defined as the retracted limit of shaft travel. The heavy line indicates a closed circuit. Follow these instructions to change the operating point of auxiliary switches:

NOTE: In the following procedure, it is assumed that switch settings are to be adjusted so that contacts are open when the desired position is achieved. If they are to be adjusted to close, it may be necessary to reverse the operating mode of the switch by reversing the leads on the switch itself. Be sure to disconnect power from the switch terminals first.

1. Remove the top cover (15/16" bolt head). The O-ring seal will remain in the rim of the cover when removed. Open the terminal block cover (1/2" bolt heads).
2. Use the electric Handswitch to drive the shaft so that the switch cam is accessible. Using a 7/64" hex wrench, loosen the screw so that the cam is just snug on the shaft.
3. Move the output shaft to the desired position.
4. Disconnect power from the drive.
5. Connect the continuity meter across the appropriate terminals. See the chart on page 21 or the actuator wiring diagram. Rotate the cam until the meter shows no continuity (switch contacts open, switch clicks).
6. Tighten the cam locking screw to 5 lb-in (0.56 N•m) torque.
7. Disconnect the meter and reconnect power.
8. Move the actuator's output shaft in the desired direction so that the cam lobe moves away from the switch lever. If not correct, return to step 2 and reset the cam to the proper orientation.
9. Reconnect the meter.
10. Move the output shaft again toward the desired switch position. If the contacts open, the switch is properly set.
11. Close covers and tighten the terminal cover bolts to 10 lb-ft (14 N•m) torque. Tighten the top cover just enough to compress the O-ring seal.

CALIBRATION Stroke Change

STROKE CHANGE—CALIBAR

Adjustment of the total actuator stroke within the factory-set travel range is easily accomplished by the use of the Beck Calibar, Figure 7. The switches and feedback device are simultaneously adjusted to maintain full input span when the Calibar setting is changed. For stroke lengths longer than the factory-set travel limits material modifications are necessary—consult the factory.

Adjust the actuator stroke as follows:

1. Remove the top cover. The protective O-ring seal will remain in the rim of the top cover when removed.
2. The Calibar index is graduated directly in inches, which corresponds to the actuator travel span.
3. Loosen the two locking screws on the Calibar block with an 1/8" hex wrench (See Figure 7, this page).
4. Slide the Calibar block, aligning the notch with the desired travel span on the Calibar index. Tighten the set screws.
5. Use the Handswitch to operate the actuator and check the stroke on the travel index of the valve yoke.
6. Replace the top cover after making adjustments. Tighten the top cover just enough to compress the O-ring seal.

NOTE: The limit switches and feedback device are adjusted automatically when the Calibar setting is changed. Do not adjust the limit switch cams to change the actuator stroke.

STROKE AND SPAN ADJUSTMENTS

The Calibar adjustment is designed to allow field changes of the total actuator stroke with the same maximum demand signal applied (e.g., a change from 1 1/2" (38 mm) stroke with 20 mA demand signal to a 1" (25.4 mm) stroke with 20 mA demand signal).

The span adjustment on the ESR-5 board is used to maintain the actuator stroke when a change

in demand signal (or span) is required (e.g., a change from 3/4" (19 mm) stroke with a 20 mA maximum demand signal applied to 3/4" (19 mm) stroke with an 18 mA maximum demand signal applied).



Figure 7

CALIBRATION Changing Direction of Travel

CHANGING DIRECTION OF TRAVEL

Direction of travel is defined as the direction of output shaft motion produced by an increasing signal. Unless otherwise specified at the time of order, the output shaft is factory set to retract in response to an increasing signal to open the valve.

The procedure to change the direction of travel of the output shaft varies by model number. The model number is listed on the actuator name plate. Determine the model number and refer to one of the following procedures.



CAUTION

Be sure the actuator is disconnected from the line voltage and that all auxiliary switches are disconnected from the external power sources before beginning the direction change procedure.

Models 14-_03 and 14-_04

1. Remove the top cover (15/16" bolt head). The O-ring seal will remain in the rim of the top cover when removed.
2. Interchange the yellow and black wires on the common terminals of the RET and EXT travel limit switches.
3. Replace the top cover. Tighten the cover bolt just enough to compress the O-ring seal.

Models 14-_05 and 14-_07

NOTE: On model 14-107 units equipped with an auxiliary film potentiometer, the auxiliary potentiometer is mounted closest to the sector gear end of the control shaft.

1. Remove the top cover (15/16" bolt head). The O-ring seal will remain in the rim of the top cover when removed.
2. For model 14-_07, interchange the wire jumpers connected to terminals M and N.
3. Interchange the wires connected to the ends of the potentiometer. The wire on terminal 1 or 5 should be moved to the opposite terminal. Also move the wire on terminal 2 or 4 to the opposite terminal. The wire to terminal 3 remains unchanged.

Auxiliary Potentiometer Only

4. Reverse the wires connected to the ends of the potentiometer. Move the wire on terminal 1 or 5 or on terminal 2 or 4 to the opposite terminal.
5. Replace the top cover. Tighten the cover bolt just enough to compress the O-ring seal.

Models 14-_06 and 14-_08

1. Open the terminal compartment (1/2" bolt heads) and remove the top cover (15/16" bolt head). The O-ring seal will remain in the rim of the top cover when removed.
2. For model 14-_08, interchange the wire jumpers connected to terminals M and N.
3. Install a mA meter in series with a 200 ohm load resistor for current outputs or a voltmeter across the CPS-5 output terminals for voltage outputs (see Table 11, page 44).
4. Reconnect actuator power.
5. Drive the output shaft until the CPS-5 output is 50% of the range (e.g. for 4–20 mA signal range, set output to 12 mA).
6. Set Handswitch to STOP position.
7. Using a 7/64" hex wrench, loosen the CPS-5 rotor clamp.
8. Rotate the CPS-5 rotor 180° and set the output back to the mid-range (e.g. 12 mA).
9. Tighten rotor clamp (see Figure 8, page 28).
10. Run the actuator to the retract and extend limits with the Handswitch. Record CPS-5 output at limits.
11. Subtract outputs recorded at the two limits and compare with the desired output signal span (e.g., 16 mA or 4 V dc).
12. Move the actuator to the retract limit.
13. Divide the difference between the measured span, step 11, and the desired span by 2. Adjust the Span Potentiometer by this amount (see Figure 9, page 28). NOTE: CW movement of the Span Potentiometer moves the ends of the signal range away from each other, while CCW movement moves the ends of the signal range toward each other.
14. Loosen the rotor clamp and adjust the rotor position to achieve the desired value of maximum output signal (e.g. 10 mA or 5 V dc). NOTE: Rotor adjustment moves the entire signal span up or down.
15. Tighten rotor clamp and run output shaft to retract and extend limits to check CPS-5 signal for desired span. If incorrect, repeat step 11.
16. Tighten rotor clamp to 5 lb-in (0.56 N•m) torque. Maintain 0.031" (0.79 mm) clearance between rotor clamp and stator.
17. Remove meter and resistor and reconnect output wiring.
18. Close covers and tighten the terminal cover bolts to 10 lb-ft (14 N•m) torque. Tighten the top cover just enough to compress the O-ring seal.
19. Model 14-_08: Recalibrate ESR-5 Board.

CALIBRATION Feedback Signal

FEEDBACK SIGNAL CALIBRATION

Feedback signal calibration is necessary to ensure that signal current or voltage correctly corresponds to the actuator's output shaft position. All Group 14 actuators are shipped with the feedback calibrated for full retraction of the output shaft unless otherwise specified at time of order.

The procedure to check and set feedback calibration varies by model number. The model number is listed on the actuator name plate. Determine the model number and refer to the proper procedure below.

NOTE: The shaft travel limit switches must be properly adjusted before the feedback signal is calibrated. The feedback signal must be calibrated before the demand signal can be calibrated.

Film Potentiometer Calibration Models 14-_05 and 14-_07

NOTE: On Model 14-_07 units equipped with an auxiliary film potentiometer, the auxiliary potentiometer is mounted closest to the sector gear end of the control shaft.

When properly adjusted, the auxiliary potentiometer feedback signal should be maximum with the actuator shaft in the fully retracted (maximum demand signal) position. At 50% of travel, the signal should be mid-span. At full extension, the signal should be minimum.

On option 7 units, potentiometer feedback to the ESR-5 board should read 0.54 V dc at the minimum demand signal position and 2.66 V dc at the maximum demand signal.

If either the auxiliary or main potentiometers on option 7 units is out of calibration, or if the feedback potentiometer on option 5 units is out of calibration, the procedure to recalibrate is the same:

1. Open the terminal block cover (1/2" bolt heads) and remove the top cover (15/16" bolt head).
2. Loosen the clamping screw (use 9/64" hex wrench) on the potentiometer wiper so that it is just snug on the shaft.
3. Operate the actuator to the electrical limit corresponding to maximum demand signal.

4. Set the wiper on the potentiometer so that the voltage reaches its maximum value. Auxiliary feedback signals are read by a multimeter at the terminal block (CC, DD, EE). Feedback signals to the ESR-5 board are read on the board at TP3 and TP2 (see Figure 11, page 31, for location).

NOTE: Be sure that the wiper spans the resistor and collector elements equally, and does not touch the areas of low resistance at either end of the film element.

5. Tighten the clamping screw to 5 lb-in (0.56 N•m) torque.
6. Operate actuator between electrical limits. Verify the feedback signal is properly adjusted.

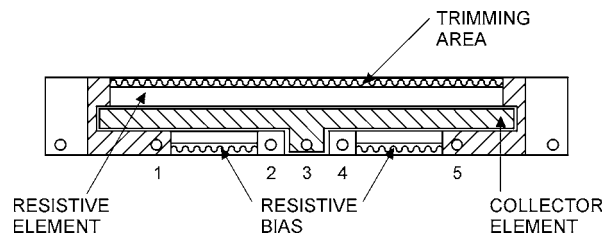

7. Use the manual Handwheel to run the actuator to the mechanical limit; do not overtorque, as damage may result.
8. Check that the wiper does not come off the resistive element or output voltage does not fall from maximum value. If not correct, return to step 2.
9. Replace the top cover and close the terminal block cover. Torque the terminal cover bolts to 10 lb-ft (14 N•m). Tighten the top cover bolt just enough to compress the O-ring seal.

STANDARD FILM POTENTIOMETER CONNECTIONS FOR THE ESR

Model	Output Shaft Movement Increasing Signal	Wire Connections To Potentiometer Terminals*				
		1	2	3	4	5
107, 207	Retract		GRN	YEL		ORG
	Extend	ORG		YEL	GRN	

*ORG wire is ESR pin 3; YEL wire is ESR pin 4; GRN wire is ESR pin 5.

CALIBRATION Feedback Signal

CPS-5 Calibration

Model 14-_06 and 14-_08

These models are equipped with a Contactless Position Sensor (CPS-5) for position sensing and feedback. On model 14-_08, the CPS-5 also delivers a feedback signal to the Electronic Signal Receiver (ESR-5). Adjusting the remote feedback signal also automatically adjusts the ESR-5 signal.

CPS-5 units are designed to provide position feedback without contacting or wiping surfaces. On option 8 units, the CPS-5 includes a Monitor / Isolator board which detects high and low out-of-limit conditions. The Monitor function monitors the CPS-5 position signal and compares it to established limits. If the output exceeds normal signal conditions, the monitor relay contact opens. This relay may be used for a remote signal indication or activation of Loss-of-Signal operation.

The CPS-5 provides infinite resolution by means of a ferrite rotor on the control shaft and a ferrite stator on the CPS-5 board. To make feedback signal adjustments, adjust the span, then change the position of the rotor on the control shaft to adjust the zero.

Checking Feedback Signal Calibration

To check CPS-5 calibration:

Tools required:

- mA / V dc Multimeter
- 1/2" Combination Wrench
- 15/16" Combination Wrench
- 200 ohm Resistor

1. Put electric Handswitch in STOP position.
2. Open the terminal block cover (1/2" bolt heads) and top cover (15/16" bolt head).
3. Determine the correct feedback terminals from the wiring diagram supplied with your actuator (CC, DD, EE).
4. Install a mA meter in series with a 200 ohm load resistor for current outputs, or a voltmeter across the CPS-5 output terminals for voltage outputs (see Table 11, page 44).
5. Drive the output shaft through its full range and check the feedback signal.

When properly adjusted, the feedback signal should be maximum with the actuator's output shaft in the fully retracted (maximum demand signal) position. At 50% travel, the signal should be mid-span. At full extension, the signal should be minimum. If not correct, proceed with the calibration procedure.

Calibration Procedure

Adjustment of the CPS-5 is necessary if the signal range requires an increase or decrease in value relative to the actuator's output shaft stroke. Calibrate by turning the Span Potentiometer CW to increase the gain of the CPS-5. This has the effect of increasing the output at the high end and lowering the output at the low end equally.

Signal Span is determined by the CPS-5 model and ranging resistor selected.



CAUTION

Do not adjust the zero potentiometer to shift the span.

To adjust the span, turn the Span Potentiometer on the CPS-5 circuit board. The Span Potentiometer adjusts the CPS-5 so that the actuator output shaft motion produces the specified output signal range.

Tools required for calibration:

- mA / V dc Multimeter
- 3/32" Screwdriver
- 7/64" Hex Wrench
- 5/16" Open End Wrench
- 1/2" Combination Wrench
- 15/16" Combination Wrench
- 1/32" Thickness Feeler Gauge
- 200 ohm Resistor

1. Put electric Handswitch in STOP position.
2. Open the terminal block cover (1/2" bolt heads) and top cover (15/16" bolt head). The O-ring seal will remain in the rim of the top cover when removed.
3. Determine the correct feedback terminals from the wiring diagram supplied with your actuator (CC, DD, EE).
4. Install a mA meter in series with a 200 ohm load resistor for current outputs or a voltmeter across the CPS-5 output terminals for voltage outputs (see Table 11, page 44).
5. Move the actuator to the fully extended position and record the signal voltage or current.
6. Move the actuator to the fully retracted position and record the signal voltage or current.
7. Subtract the two signal readings and compare to the desired output signal span. For example, 16 mA for 4–20 mA signal range. Divide the difference between the measured and desired span by 2. Adjust the Span Potentiometer by this amount with the actuator at the 100% position. CW movement of the Potentiometer increases the span equally at both

ends. CCW movement of the Potentiometer decreases the span equally at both ends (see Figure 9, page 28, for location of Span Potentiometer).

8. Loosen the rotor clamp and reset its position (use the thickness gauge; see Figure 8, page 28) to achieve the desired value of maximum output signal. For example, 20 mA. NOTE: Rotor adjustment moves the entire span up or down. Also observe the meter as you rotate the rotor to ensure that the signal is changing in the proper direction.
9. Tighten the rotor clamp to 5 lb-in (0.56 N•m) torque.
10. Move the output shaft to the fully extended and fully retracted positions and check the output signal for desired span. If not correct, repeat the procedure from step 5.
11. Remove the meter and resistor, reconnect feedback wires, and replace covers.
12. Torque the terminal cover bolts to 10 lb-ft (14 N•m). Tighten the top cover bolt just enough to compress the O-ring seal.
13. Return electric Handswitch to AUTO position and process controller to automatic mode.
14. On Model 14-108, recalibrate the ESR-5 board.

Adjusting the Zero Potentiometer

The Zero Potentiometer is provided on CPS-5 models 20-3400/4400-03 and -13 to change from a suppressed zero to a zero-based range (e.g. from 1–5 V dc to 0–16 V dc). The zero is adjustable from -5% to +30% of span.



CAUTION

The zero is factory sealed on all CPS-5 units except 20-4400-03 and -13. Do not attempt to adjust the zero on other models as misadjustment of feedback signal and monitor/ isolator functions will result.

NOTE: Do not adjust the zero potentiometer to shift calibration. Adjust the rotor position only to shift calibration.

The following example is given to illustrate how the zero is adjusted to effect a range change from 1–5 V dc to 0–16 V dc:

1. Install the 1–5 V dc unit as a 1–5 V dc range. Do not make any adjustments other than setting the rotor position.

2. Remove jumper from terminals CC to DD and replace with a 3.01K ohm resistor (see Table 11, page 44). This shifts the range to 4–20 V dc.
3. Using a voltmeter at the appropriate output terminals, adjust the Zero Potentiometer with the actuator at minimum demand signal position so that output reads 0 V dc. This changes the range to 0–16 V dc.

FEEDBACK SIGNAL MONITOR / ISOLATOR

CPS-5 models 20-3400/4400-12, -13, -14, and -15 are provided with a Monitor / Isolator board which delivers an isolated position feedback signal to the Electronic Signal Receiver (ESR-5). The Monitor function monitors the CPS-5 position signal and compares it to established limits. If the output is outside normal signal conditions, the monitor relay contact opens. This relay may be used for either a remote signal indication or activation of Loss of Signal operation of the drive.

No adjustments should be made on the Monitor / Isolator board.

Signal Monitor Sensing Operation

A red LED indicator and an SPST relay are mounted on the Monitor / Isolator board to indicate that power is on and that the CPS-5 output signal is within normal range. Normal operating range is -1% to +101% (contacts closed) and -4% to +104% (contacts open).

The SPST relay is rated for 0.1 amp resistive at 100 V dc and can be used for remote monitoring of the actuator's power or to signal a system failure.

Loss of Signal Operation

Group 14 actuators equipped with Electronic Signal Receivers (ESR-5) are configured so that the input control signal is connected through the relay on the monitor board of the CPS-5. The Loss of Signal (L.O.S.) function of the ESR-5 may therefore be activated when the CPS-5 signals are outside the normal range (see above). To have an out-of-range CPS-5 signal trigger the L.O.S. mode, remove the jumper across the relay contacts on the monitor board. See the schematic on page 45 for jumper location. For details on L.O.S. function, review the following section on Demand Signal Calibration.

CALIBRATION Feedback Signal

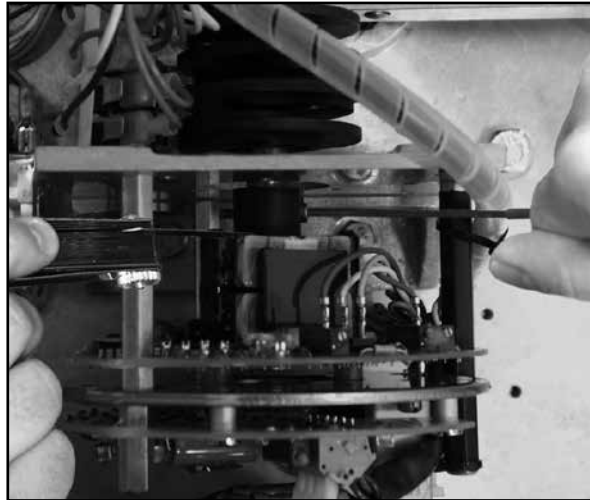

Figure 8

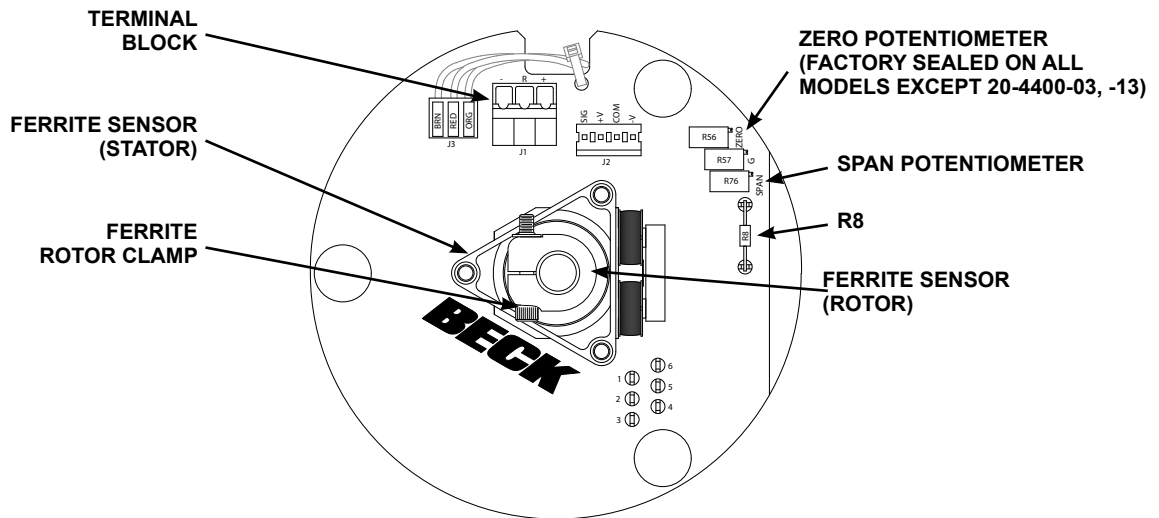

Figure 9: CPS-5 Position Sensor

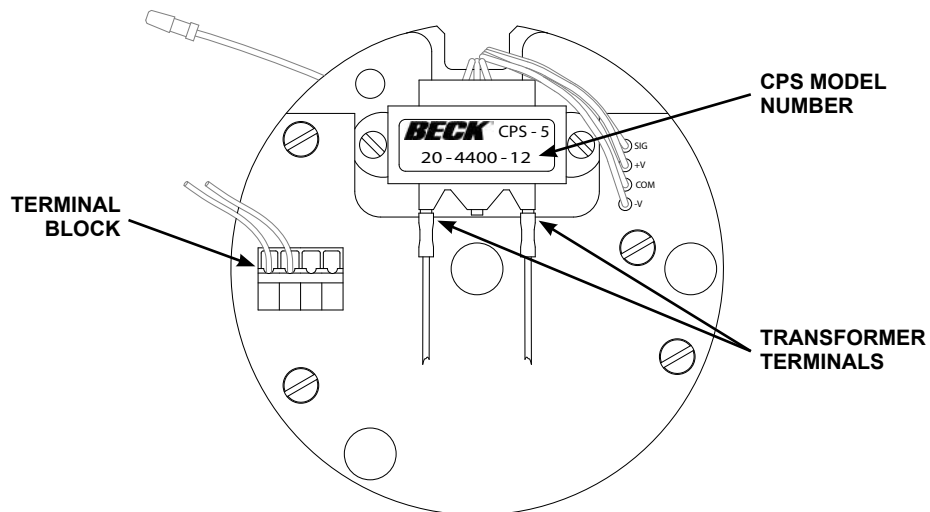

Figure 10: CPS-5 Monitor/Isolator Assembly

CALIBRATION Demand Signal

DEMAND SIGNAL CALIBRATION

All Group 14 actuators equipped for milliamp or dc analog modulating applications include a fourth generation Electronic Signal Receiver (ESR-5). The ESR-5 board consists of a voltage regulator, a signal amplifier, an error amplifier, and three solid state output switches.

The ESR-5 board controls the position of the Beck actuator according to the demand signal it receives. A feedback signal is delivered to the board from either a potentiometer or the CPS-5, which is then compared with the demand signal. The error signal is amplified and used to actuate either of two switches to retract or extend the output shaft until the signals balance and the error is zero.

The third output switch is energized when the signal falls below a given setting. This L.O.S. can be used to drive the output shaft to a predetermined position. See section on L.O.S., page 27, for further details.

NOTE: The demand signal is calibrated relative to the output (feedback) signal. Therefore, the shaft travel limit switches must be properly adjusted and the feedback signal calibrated before the demand signal can be calibrated.

Checking Calibration

Using the input control signal, drive the output shaft through its complete range. Check the position feedback signal to confirm that a 10% demand signal delivers a 10% position, a 50% signal delivers a 50% position, and a 90% signal delivers a 90% position. If the feedback signals do not correspond to the appropriate demand signals, then the ESR-5 must be calibrated. The tolerance on factory calibration is $\pm 0.5\%$ of span.



CAUTION

The signal circuit on ESR-5 units is not grounded. If grounding is required, connect terminal BB in the terminal compartment to ground, either on the actuator body or externally.

Calibration Tips

The demand signal can be varied by the automatic controller, but if that is impractical, a test box may be used. Connect the test box to positive terminal AA and negative terminal BB of the terminal block in place of the controller input.

Span and zero adjustments are located near the edge of the ESR-5 board (see Figure 11, page 31). Monitor the "FWD" and "REV" LEDs to make

adjustments. When the actuator is balanced (with Handswitch in "AUTO" and not at an over-travel limit) both direction LEDs are off; when in L.O.S. mode, direction LEDs are off, but the L.O.S. LED is lit. When the output shaft is moving, the LED designating its direction of travel is lit and the other LED is off. When the actuator reaches its end of travel before balance is achieved, the LED will stay lit. Trim the adjustment so that the actuator just reaches the limit and the motor does not run. Clockwise rotation of either span or zero adjustment causes the output shaft to drive toward the zero (minimum demand signal) position.

Calibration Procedures

NOTE: Two calibration procedures are described below. The first procedure is to be followed if the span is in error by less than 15%. If the span is in error by more than 15% follow the second procedure.



CAUTION

Actuator will run during the following procedures.

Tools required:

- 3/32" Screwdriver
- 1/2" Combination Wrench
- 1/4" Screwdriver
- mA / V dc Multimeter
- 200 Ohm Resistor

If the span is in error by less than 15%:

1. Turn the Handswitch to the "STOP" position.
2. Remove the ESR cover and the terminal block cover (5/16" bolt heads).
3. Determine the correct external Feedback signal terminals from the wiring diagram supplied with the actuator (located on the inside of the terminal block cover). Connect a meter (if applicable) to monitor the Feedback signal:
 FOR CURRENT FEEDBACK APPLICATIONS:
 Record the color and location of the Feedback signal wires (for reconnection later). Remove the two Feedback wires. Connect a mA meter in series with a 200 ohm load resistor.
 FOR VOLTAGE FEEDBACK APPLICATIONS:
 Connect a voltmeter across the Feedback terminals. DO NOT remove the Feedback signal wires. See your actuator instruction manual for appropriate Feedback terminals. Note: For actuators equipped with control option 7 without an auxiliary potentiometer, it is not possible to use terminals CC, DD and EE for signal measurements during calibration;

Continued

CALIBRATION Demand Signal

CALIBRATION PROCEDURES, CONT'D.

instead, an external reference must be used to determine the output shaft position.

4. Connect a signal source to the Demand signal terminals, AA (+) and BB (-).
5. Turn the Handswitch to the "AUTO" position.
6. Apply the desired 0% Demand signal to the actuator (e.g., 4 mA for a 4–20 mA input).
7. Using a 3/32" screwdriver, adjust the zero potentiometer CCW until the motor runs and the output shaft position is at least 2° from the desired 0% position. Both the "REV" & "FWD" LED will be off.
8. Adjust the zero potentiometer CW in small increments until the output shaft is at the 0% position. For actuators equipped with external Feedback, the Feedback signal reads 0% (e.g., 4 mA for a 4–20 mA signal). Once at the 0% position, both LEDs should be off.
9. Apply the desired 100% Demand signal to the actuator (e.g., 20 mA for a 4–20 mA signal).
10. Using a 3/32" screwdriver, adjust the span potentiometer CW until the motor runs and the output shaft position is at least 2° from the desired 100% position. The "FWD" LED will light and remain lit.
11. Adjust the span potentiometer CCW in small increments until the output shaft is at the 100% position. For actuators equipped with external Feedback, the Feedback signal reads 100% (e.g., 20 mA for a 4–20 mA signal). The "REV" LED will light and the "FWD" LED deactivate. Once at the 100% position, both LEDs should be off.
12. Apply the desired 0% Demand signal and confirm that the output shaft is at the 0% position (the Feedback signal reads 0%). If not, adjust the zero potentiometer.
13. Apply the desired 100% Demand signal and confirm that the output shaft is at the 100% position (the Feedback signal reads 100%). If not, adjust the span potentiometer.
14. Repeat steps 12 and 13 until the meter readings stay within an acceptable range.
15. Remove the meter and any local signal sources and reinstall the Demand signal and Feedback signal wiring. Replace the compartment covers and tighten the bolts to 10 lb-ft (14 N•m).

For a span error greater than 15%:

1. Turn the Handswitch to the "STOP" position.
2. Remove the ESR cover and the terminal block cover (5/16" bolt heads).
3. Determine the correct external feedback signal terminals from the wiring diagram

supplied with the actuator (located on the inside of the terminal block cover). Note: For actuators equipped with control option 7 without an auxiliary potentiometer, it is not possible to use terminals CC, DD and EE for signal measurements during calibration. Instead, an external reference must be used to determine the actuator output shaft position.

4. Connect a meter (if applicable) to monitor the feedback signal.
5. Turn the Handswitch to the "AUTO" position.
6. Short the demand signal terminals AA and BB.
7. Short resistor R35 temporarily with a clip lead. Note: The board has conformal coating; take extra care to ensure proper connection.
8. Using a 3/32" screwdriver, adjust the zero potentiometer CW in small increments until the output shaft is at the 0% position. For actuators equipped with external feedback, the feedback signal reads 0% (e.g., 4 mA for a 4–20 mA signal).
9. Remove the short on the demand signal terminals and apply a demand signal equal to the span (e.g., 16 mA for a 4–20 mA signal). If the actuator has not been wired, the demand signal is connected at terminals AA (+) and BB (-).
10. Using a 3/32" screwdriver, adjust the span potentiometer CCW in small increments until the output shaft is at the 100% position. For actuators equipped with external feedback, the feedback signal reads 100% (e.g., 20 mA for a 4–20 mA signal).
11. Remove the clip lead from R35. Apply the desired 100% demand signal (e.g., 20 mA for a 4–20 mA signal).
12. Adjust the zero potentiometer CCW (may require 10–15 turns) until the output shaft is at the 100% position (the feedback signal reads 100%).
13. Apply the desired 0% demand signal and confirm that the output shaft is at the 0% position (the feedback signal reads 0%). If not, adjust the zero potentiometer.
14. Apply the desired 100% demand signal and confirm that the output shaft is at the 100% position (the feedback signal reads 100%). If not, adjust the span potentiometer.
15. Repeat steps 13 and 14 until satisfied with the adjustment.
16. Remove the meter and any local signal sources and reinstall the demand signal and feedback signal wiring. Replace the compartment covers and tighten the bolts to 10 lb-ft (14 N•m).

Span

The basic span adjustment of the ESR-5 is 2–6 volts dc. This is adjustable with the 20-turn span potentiometer. To make the span adjustable from 2–9 volts dc, remove jumper J2. To make the span adjustable from 9–12 volts dc, remove jumper J1. To make the span adjustable from 12–16 V dc, remove J1 and J2. See Figure 11, this page for location of jumpers on the ESR-5 board.

Zero (Supp.)

The basic zero adjustment is -20% to 100% of span. This is adjustable with the zero potentiometer. For 2-way split range applications, remove resistor R35 to shift the zero adjustment to 20% to 150% of span. For 3-way split range operation, remove resistors R35 and R36 to shift the zero adjustment to 150% to 275%. For other split range applications, consult factory for adjustment. See Figure 11, this page, for location of R35 and R36.

Filter Adjustment

The input filter is adjusted at the factory for maximum attenuation of disturbances on the demand signal (fully CW). This introduces a 1% drift (with 4" (102 mm) travel at 16 sec./in. (0.63 sec./mm) timing) in response to a loss of demand signal when stay-in-place is selected. If this is objectionable or if livelier response is desired, the filter action can be reduced by turning the filter adjustment potentiometer CCW a sufficient amount. Full CCW takes the filtering out completely, but in some cases may lead to undesirable cycling. If this happens, turn the adjustment CW until the cycling is damped out.

Deadband Adjustment

The deadband values of 0.6% for CPS-5 or film potentiometer operation are chosen to satisfy the requirements of most control systems. If excessive process and / or signal noise is present, the actuator may be subject to unnecessary cycling. It is recommended that excessive noise be reduced at the source in order to prevent unnecessary cycling. This will improve process control and prolong component life.

If it is not possible to eliminate the excessive noise, the actuator's deadband can be widened; however, this will reduce the resolution of the actuator. Widening the deadband to 1% can be accomplished by removing jumper J3 on the ESR-5 board. Further change of the deadband is possible by changing the value of R42, but only after J3 is removed. See following table.

DEADBAND/RESISTOR VALUES

J3	R42	Deadband
Remove	4.99 MΩ	1.0%
Remove	3.30 MΩ	1.6%
Remove	2.20 MΩ	2.4%
Remove	1.50 MΩ	3.5%

L.O.S. TRIP POINT

If the Demand signal drops below a predetermined value, the L.O.S. feature is activated. For example, if the Demand signal is 4–20 mA, the L.O.S. trip point would be approx. 1.92 mA, with normal operation resuming before the signal reaches 4.0 mA. If the Demand signal is 1–5 V, the L.O.S. trip point would be 0.48 V, with normal operation resuming before the signal reaches 1 V.

If it is necessary to change the L.O.S. trip point, resistors R20 and R21 must be replaced. See the applicable table below.

The L.O.S. function may be disabled by removing R19.

L.O.S. TRIP POINT/RESISTOR VALUES (FOR CPS EQUIPPED ACTUATORS)

L.O.S. Trip Point mA	% of Span	L.O.S. Reset Point, mA	% of Span	Resistor Values	
				R20 KΩ	R21 KΩ
2.1	12	3.6	2.5	30.1	4.42
1.6	15	3.6	2.5	37.4	7.32
0.8	20	3.6	2.5	38.3	11.3

L.O.S. TRIP POINT/RESISTOR VALUES (FOR FILM POT. EQUIPPED ACTUATORS)

L.O.S. Trip Point mA	% of Span	L.O.S. Reset Point, mA	% of Span	Resistor Values	
				R20 KΩ	R21 KΩ
2.1	12	3.6	2.5	30.1	4.42
1.4	16	3.6	2.5	35.7	8.25
0.8	20	3.6	2.5	36.5	11.3

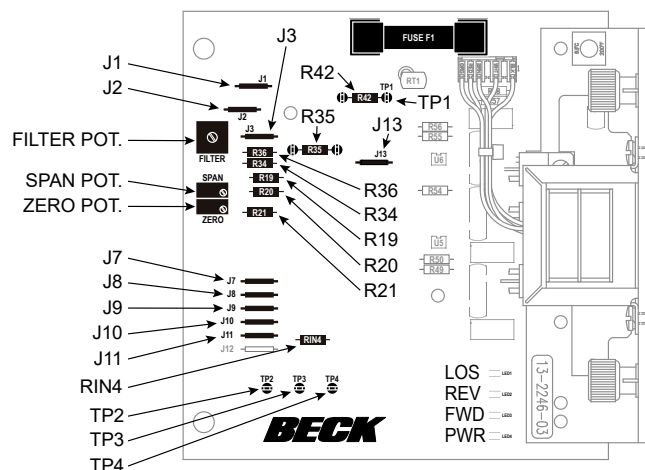

Figure 11: ESR-5 Components (13-2246-03 shown)

MAINTENANCE Routine

The Beck Group 14 actuator requires only minimal routine maintenance. Periodic visual inspections are recommended to verify that the connection to the valve is intact and operating normally. If vibration is present, check the electrical terminal connections and other hardware for tightness.

LUBRICATION

Periodic lubrication is not required on Beck actuators. However, during major maintenance outages, it is recommended that older actuators should be inspected to ensure that the gearing is not worn or damaged.



CAUTION

Before removing the gear housing assembly, block the valve stem to prevent the gear train from moving when the housing assembly is removed.

To inspect or lubricate the output gear only, remove the cover plate (1/2" bolt heads) on the side opposite the motor. The output gear is not field replaceable.

To inspect all the gears, first remove the motor from the housing, following the instructions on page 33. Then, remove the housing assembly from the body (1/2" bolt heads). Clean all parts thoroughly, removing as much old lubrication as possible. Examine the gear teeth for signs of excessive wear, scoring, or other damage. Check for excessive free play of gears on shafts. The assembly is not field repairable and should be returned to the factory if excessive wear is noted.

Before reassembly, recoat the teeth with a heavy layer of Fiske Lubriplate GR-132 or equivalent. GR-132 is an E.P. grease with polymer additives. To reinstall the gear housing, carefully position the housing on the body's alignment pins. Replace the bolts and tighten to 10 lb-ft (14 N•m).

Reattach the motor per the instructions on page 33.

MAINTENANCE *Component Replacement*

This section covers replacement of many components of the Group 14 drive. Note that some components are not field repairable.

If it should ever be necessary to replace the output gear, shaft, or output shaft bearings, a major overhaul is required and the actuator should be returned to the factory.

GASKETS

During routine service, inspect the gaskets and O-rings for wear or damage. In order to protect internal components, worn or damaged gaskets and O-rings should be replaced.

To remove the main gear cover, terminal compartment, or the motor gaskets, scrape all of the old adhesive and gasket material from the body housing and cover. Cement the new gasket to the actuator body using a gasket cement such as 3M #847 Rubber and Gasket Adhesive, or equivalent.

O-ring seals are used between the body and the top and bottom bearing plates. Before installing a new O-ring, lubricate it with light machine oil.

The large top cover is sealed with rubber foam gasket material, 5/16" (8 mm) in diameter. To replace this material, scrape the old gasket material and cement from the groove. Cement the new foam gasket into the groove with 3M #847 Rubber and Gasket Adhesive, or equivalent. Cut the ends of the material on an angle and cement them together with this same adhesive.

SEALS

Worn or damaged output shaft and motor shaft seals should be replaced to prevent damage to internal bearings and actuator train parts.

To remove the shaft seal, push the blade of a small screwdriver along the shaft and under the seal lip. **CAUTION:** The seal is approximately 1/4" (6.4 mm) wide. Do not force the screwdriver blade beyond the width of the seal; damage to the shaft bearing could result. Pry up on the seal and force it out of the housing. Clean the shaft and housing and press in the replacement seal with the closed side facing outward.

BEARINGS

There are some field replaceable bearings in the Group 14 drive. Consult the factory for details.

MOTOR

The control motor is not field-repairable. Disassembly of the motor will result in a loss of torque that can only be restored by returning the motor to the factory for remagnetizing.



CAUTION

Before removing the motor assembly, while the process is running, block the valve stem to prevent the gear train from moving when the motor is removed.

To remove the motor, first disconnect the motor wires in the terminal compartment of the control drive. The wiring is under the terminal board. Remove the black wire from the terminal post, cut the green motor wire near the green-yellow-red butt joint and disconnect the red wire from the re-green-blue butt connection. Remove the hardware that secures the motor (model 14-10_ has three 10-32 socket head cap screws and model 14-20_ has four 1/4-20 hex head bolts). Carefully slide the motor out of the actuator body.

To install the motor, insert the three-wire sleeve through the wire hole in the motor mount and into the terminal compartment. Carefully slide the motor into the actuator body, rotate the motor shaft if necessary to engage the pinion with the first combination gear. Install motor mounting hardware and torque to appropriate values (10-32 socket head cap screws (20 lb-in) (2.26 N•m) or 1/4-20 hex bolts (6 lb-ft) (8.13 N•m)). Reconnect the motor wires.

NOTE: 14-100 models with 4 and 8 second timing have a spacer between the motor and gear module.

MOTOR RESISTOR AND CAPACITOR

The motor resistor assembly and capacitor are located in the top compartment beside the Calibar. To replace a resistor or capacitor, remove the top cover (15/16" bolt head). Remove the existing part and transfer the wires one at a time to the replacement part. Inspect the top cover gasket and replace if necessary. Replace the top cover. Tighten the top cover bolt just enough to compress the O-ring seal.

MAINTENANCE Component Replacement

LIMIT AND AUXILIARY SWITCHES

Complete switch assemblies may be replaced. It is not possible to replace individual switches. To replace switch assemblies, remove the top cover (15/16" bolt head). Remove the #6-32 socket head cap screws holding the switch assembly to the plate.

Transfer the wires one at a time to the replacement assembly using the push-on lugs provided. Install the replacement assembly and note that it rotates around one screw to permit an adjustment of the cam-to-roller spacing and switch operating point. To properly set the switch, use a .030" (.75 mm) shim between the cam and switch lever and loosely position the switch assembly so that the switch is just actuated. The switch lever should be on the low or minimum radius portion of the cam when setting the switches. DO NOT overstress the switch lever. Tighten both screws to 10 lb-in (1 N•m) torque and remove the shim. When properly adjusted, the switch lever should remain in contact with the cam throughout the control actuator travel.

ADDING SWITCHES

It is possible to add up to four switches to a control actuator in the field. Consult the factory, giving the control actuator model and serial number so that a correct list of parts required may be supplied to you.

Remove the top cover (15/16" bolt head). Install wiring onto the switch push-on lugs and route the wires into the control actuator terminal area. Remove the terminal cover and solder wires to the underside of the terminal assembly according to the wiring diagram included with the new switch assembly. Install the new switch assembly and adjust according to the instructions above. See Table 5, page 39, for switch assembly part numbers.

SELF-LOCKING MECHANISM (SLM)

In normal service, the SLM friction surface should not require replacement; however, a combination of excessive modulation and load can cause wear to the SLM mechanism. If the SLM has been damaged, rebuild kits are available (see table below).

SLM Rebuild Kits typically consist of a spring, spring pin, thrust bearing, pinion, steel balls, locking disc, steel shims, control motor gasket, terminal joints, friction material liner and instruction sheet.

See the figure below for identification of typical SLM components.

TABLE 4

Motor Part Number	SLM Rebuild Kit		Instruction Sheet
	NF-119	GL181-134	
20-2702-31	n/a	12-8067-19	80-0016-09
20-2703-31	n/a	12-8067-19	80-0016-09
20-2703-34	n/a	12-8067-20	80-0016-09
20-2703-35	12-8060-22	n/a	80-0016-14

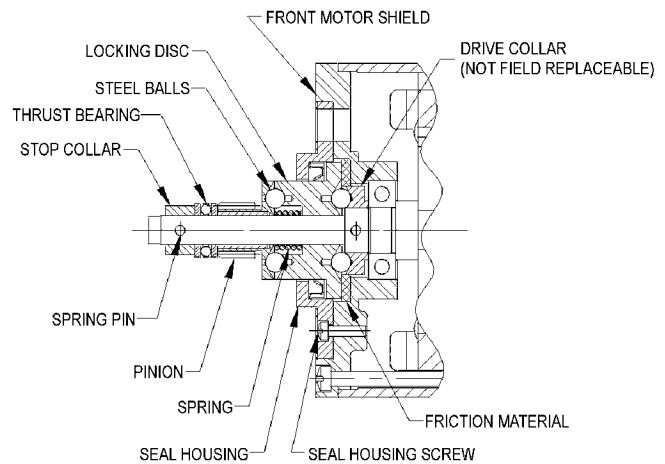

Figure 12

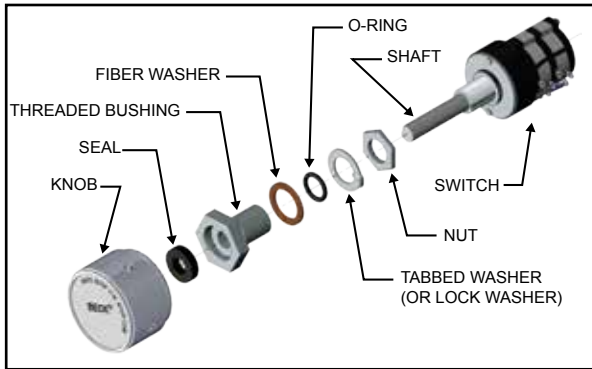

Figure 13

Handswitch

To replace the Handswitch, remove the terminal cover, ESR-5 board and ESR-5 bracket. Clip the five wires from the old Handswitch. Remove the knob and the nut under the knob to remove the switch. Install the new Handswitch as shown in Figure 13, above. Splice the wires color for color. Replace the ESR-5 bracket, board and the terminal cover. Torque bolts to 10 lb-ft (14 N•m).

NOTE: The AUTO position on the Handswitch knob must be straight up when the switch is fully clockwise. Handswitch part number 20-3300-27.

ESR-5 Board

Field service of the ESR-5 board is not recommended. The factory maintains a stock of replacement boards for immediate shipment. To replace the ESR-5 board, open the terminal compartment cover (1/2" bolt heads). Loosen the four captive screws holding the board to its mounting pads. Note the "L" shape mounting bracket on the end of the board; to remove, pull the mounting bracket away from its mating surface.

To install an ESR-5 board, lightly press the board connector into its receptacle until the mounting bracket is flush with its mounting surface. Tighten the four captive screws and close the compartment cover. Torque the cover bolts to 10 lb-ft (14 N•m).

CPS-5

Field repair of the CPS-5 assembly is not recommended. The factory maintains a stock of replacement assemblies for immediate shipment. If it is necessary to replace the CPS-5, replace both the rotor and stator / circuit board assembly.

When returning the CPS-5 to the factory for service, please include the rotor and stator / circuit board assembly. Do not separate the stator or circuit boards from their mounting plate.

It is recommended that the rotor be held inside the stator with rubber bands and the hex studs be reattached to the mounting plate for protection during shipment.

To remove the CPS-5, remove the top cover and run the actuator to the 0% position. Note direction of shaft rotation. Turn the Handswitch to STOP and turn off all AC power to the drive. Disconnect the wires from transformer and spring clamp terminals. See Figure 10, page 28. Note wire colors and locations. Pull wires through the mounting plate hole. Loosen the rotor coupling and remove the three hex stud nuts supporting the CPS-5 assembly. Support the inboard hex stud when removing nuts. Remove the CPS-5 stator / circuit board assembly and rotor.

To install the CPS-5, slide the rotor onto the control shaft (clamp end toward the limit switches). Leave the clamp loose. Assemble CPS-5 over the rotor and mounting studs, transformer out and at approximately 4 o'clock. Secure assembly with three hex nuts. Torque to 60 lb-in (6.77 N•m). Reconnect wires.

To set CPS-5 rotor position, open the terminal cover (1/2" bolt heads) and connect a mA / V dc multimeter to the feedback terminals. See wiring diagram supplied with actuator or Table 11, page 44, for correct terminals. Run actuator to 0% position (100% for model 20-4400-04 & -14 if used for 0–15 V dc signal). Note direction of control shaft rotation. Put Handswitch in STOP. Insert .031" (0.79 mm) thickness gauge between rotor clamp and stator. See Figure 8, page 28. Position the rotor so that the slot in the rotor is aligned with the wire holes and transformer on CPS-5 board.

Set 0% rotor position by rotating the rotor 15 degrees in the direction that the control shaft moves when the output shaft moves toward the 100% position on increasing signal (CPS-5 models 20-4400-04 & 14 rotate rotor 15 degrees in direction control shaft moves when the output shaft moves toward 0% position on decreasing signal).

While reading the meter, position the rotor for the exact specified 0% output from the CPS-5. Tighten the rotor clamp to 5 lb-in (0.56 N•m) torque and remove the thickness gauge.

Run the actuator and check the CPS-5 output signal span. If it is acceptable, no further adjustments are necessary. If not, refer to page 26, CPS-5 Calibration Procedure, for further instructions. On units equipped with an ESR-5, check demand signal calibration.

Remove the meter and replace the top cover. Tighten the cover bolt just enough to compress the O-ring seal. Close the terminal cover and torque bolt to 10 lb-ft (14 N•m).

TROUBLESHOOTING

If your unit contains a Stall Protection Module (SPM) refer to publication 80-0017-03, "Troubleshooting".

CONDITIONS	POSSIBLE CAUSES	CORRECTIONS
1. Actuator will not run in either direction with demand signal applied to ESR-5. No LEDs lit on ESR-5.	<ul style="list-style-type: none"> a. Handswitch left in wrong position. b. No 120 V ac line supply. c. Fuse F1 open. d. External auto/man switch in wrong position (Position-All). e. ESR-5 failure. f. Jumpers between terminals F–N and D–M are not connected. 	<ul style="list-style-type: none"> a. Return Handswitch to AUTO position. b. Check fuses and switches in power panel. c. Check for possible shorts, then replace fuse. Use only Beck part no. 13-2230-03 for proper protection of triacs. d. Return switch to AUTO position. e. Replace ESR-5. f. Connect jumpers.
2. Actuator will not run in either direction with demand signal applied to ESR-5 board. CPS-5 LED light out and jumper removed from monitor board relay.	<ul style="list-style-type: none"> a. No power. b. Actuator positioned beyond calibrated limits. c. CPS-5 rotor position not properly set. d. CPS-5 not calibrated correctly. e. CPS-5 failure. 	<ul style="list-style-type: none"> a. Check power source. Check CPS-5 power supply voltage. Check CPS-5 power transformer. b. Position actuator with Handwheel and check limit switch settings. c. Set CPS-5 rotor position. d. Calibrate CPS-5. e. Replace CPS-5.
3. Actuator runs in only one direction in AUTO and both directions with Handswitch in RET and EXT.	<ul style="list-style-type: none"> a. ESR-5 zero adjustment incorrect. b. Handswitch failure. c. Loss of Demand signal with "Drive to Zero" or "Drive to full travel" selected. d. ESR-5 circuit board failure. e. Loss of feedback signal. 	<ul style="list-style-type: none"> a. Readjust ESR-5 zero. See Demand Signal Calibration. b. Check continuity from terminal N to V and M to U with Handswitch in AUTO position. See wiring diagram. c. Check Demand signal. d. Replace ESR-5. e. Check signal from CPS-5 or potentiometer at TP3 on ESR-5.
4. Loss of ESR-5 signal LED lights (red LED) with Demand signal applied.	<ul style="list-style-type: none"> a. ESR-5 zero adjustment incorrect. b. Demand signal reversed. c. ESR-5 failure. d. Slidewire equipped actuator with ESR-5 calibrated for CPS-5. e. Incorrect film potentiometer setting. f. Control signal wired through CPS-5 monitor relay. Monitor LED is out. 	<ul style="list-style-type: none"> a. Readjust ESR-5 zero. See Demand Signal Calibration. b. Check polarity of Demand signal. Terminal AA(+), Terminal BB(–). c. Replace ESR-5. d. Cut J3 and J13 resistors and recalibrate ESR-5. e. Reset film potentiometer. f. Actuator position beyond calibrated range. Use Handswitch or Handwheel to put actuator within normal operating range.
5. Actuator runs in the wrong direction with Demand signal applied.	<ul style="list-style-type: none"> a. Demand signal reversed. b. Actuator configured for wrong direction of travel. 	<ul style="list-style-type: none"> a. Check polarity of Demand signal. Terminal AA(+), terminal BB(–). b. Change direction of rotation.
6. Actuator does not follow Demand signal until maximum or minimum signal is reached, then drives uncontrollably to limit.	<ul style="list-style-type: none"> a. Yellow and black wires on RET and EXT limit switches reversed or potentiometer end connections reversed. b. CPS-5 feedback out of phase with control motor. 	<ul style="list-style-type: none"> a. Change direction of shaft rotation. Check correct film potentiometer connections. b. Restore proper phasing of CPS-5 feedback with control motor.

CONDITIONS	POSSIBLE CAUSES	CORRECTIONS
7. Actuator motor oscillates in AUTO mode.	<ul style="list-style-type: none"> a. Feedback potentiometer dirty. b. Excessive noise on Demand signal. c. Physical obstruction (e.g., valve jammed or load greatly exceeds rating of actuator). d. ESR-5 failure. e. Excessive wear in gear train or bearings. 	<ul style="list-style-type: none"> a. Clean or replace potentiometer. b. Check setting of input filter. May require lower gain setting if oscillation remains with maximum filter setting. c. Check operation with Handswitch and remove obstruction if present. Handswitch bypasses ESR-5. d. Replace ESR-5. e. Replace worn drive train parts.
8. Actuator motor erratic or runs in wrong direction in automatic or manual operation.	<ul style="list-style-type: none"> a. Control motor winding open. b. Control motor capacitor shorted or open. c. Control motor resistor open. 	<ul style="list-style-type: none"> a. Replace control motor. b. Replace capacitor. c. Replace resistor.
9. Actuator will not run in either direction or one direction in automatic or manual operation.	<ul style="list-style-type: none"> a. Limit switch failure. b. Handswitch failure. 	<ul style="list-style-type: none"> a. Replace limit switch. b. Replace Handswitch.
10. Actuator runs erratic from 100° to 0° and runs normally from 0° to 100° in AUTO.	<ul style="list-style-type: none"> a. Feedback potentiometer dirty. Loss of feedback voltage drives the unit towards the 100% limit. 	<ul style="list-style-type: none"> a. Clean feedback potentiometer with mild soap and water.
11. Actuator runs uncontrollably to some position, then oscillates.	<ul style="list-style-type: none"> a. Feedback potentiometer open. 	<ul style="list-style-type: none"> a. Replace feedback potentiometer.
12. Actuator does not stop at normal or desired limit of shaft travel.	<ul style="list-style-type: none"> a. ESR-5 span or zero adjusted incorrectly. b. Limit switches adjusted incorrectly. c. Loss of Demand signal. Check LED on ESR-5 . d. Limit switch failure. e. CPS-5 calibration incorrect. 	<ul style="list-style-type: none"> a. Recalibrate the ESR-5 board. b. Readjust limit switches. c. Restore Demand signal to actuator. d. Replace limit switch. e. Calibrate CPS-5.
13. Loss of Demand signal feature does not function.	<ul style="list-style-type: none"> a. Incorrectly set potentiometer. b. CPS-5 calibration incorrect. 	<ul style="list-style-type: none"> a. Reset potentiometer. b. Calibrate CPS-5.
14. Actuator drives to 100% limit with small change in Demand signal.	<ul style="list-style-type: none"> a. Feedback potentiometer power supply shorted. b. ESR-5 failure of 2.7V power supply (feedback potentiometer only). c. Wiper and low end of feedback potentiometer reversed. d. Open potentiometer element. e. CPS-5 feedback out of phase with motor control. 	<ul style="list-style-type: none"> a. Check potentiometer and wiring for shorts. b. Replace ESR-5. c. Check wiring on feedback potentiometer for proper connections. d. Replace potentiometer. e. Restore proper phasing of CPS-5 feedback with motor control.
15. Actuator drives to 100% and stays.	<ul style="list-style-type: none"> a. Handswitch left in RET/EXT position. b. Potentiometer open or complete loss of contact with wiper. c. Loss of Demand signal when FWDLOS is selected. ESR-5 LED on. d. ESR-5 zero adjustment incorrect. e. ESR-5 failure. f. CPS-5 feedback out of phase with motor control. g. Jumper between terminal F-N (F-M) not connected. h. Limit switch failure. 	<ul style="list-style-type: none"> a. Return Handswitch to AUTO position. b. Check potentiometer and replace if necessary. c. Restore Demand signal to actuator. d. Readjust ESR-5 zero. See Demand Signal Calibration. e. Replace ESR-5. f. Restore proper phasing of CPS-5 feedback with motor control. g. Connect jumper. h. Replace limit switch.

TROUBLESHOOTING

CONDITIONS	POSSIBLE CAUSES	CORRECTIONS
16. Actuator travel very non-linear: a. e.g., 4–19 mA change on input causes actuator to drive from 0% to 30%; 19–20 mA change drives 30% to 100%. b. Response normal from zero to mid-range, then runs to 100%. c. Output is 25% with 50% Demand signal, but OK at 0% and 100% inputs.	a. Wiper and high end of feedback potentiometer reversed. b. CPS-5 power supply failure. c. Actuator has square function ESR-5.	a. Check feedback potentiometer for proper connections. b. Check CPS-5 power supply voltage. See 21.b. on this chart. c. Replace with appropriate ESR-5.
17. L.O.S. operates at too high a signal level.	a. Special requirement.	a. Change L.O.S. trip point.
18. CPS-5 LED goes out during normal travel.	a. CPS-5 not correctly calibrated.	a. Calibrate CPS-5.
19. Potentiometer or CPS-5 output decreases when it should increase.	a. CPS-5 rotor position not set for proper rotation. b. End connections on potentiometer reversed.	a. Reset CPS-5 rotor position. b. Calibrate potentiometer.
20. CPS-5 output non-linear.	a. CPS-5 rotor position not set properly. b. CPS-5 zero potentiometer improperly adjusted.	a. Reset CPS-5 rotor position. b. Refer to factory.
21. CPS-5 output does not reach maximum signal, but low end calibration is correct.	a. Output is overloaded: <ul style="list-style-type: none"> • load resistance is too low for voltage range. • load resistance is too high for current range. b. Low voltage: <ul style="list-style-type: none"> • CPS-5 power failure. c. CPS-5 rotor not properly set. d. CPS-5 zero potentiometer not properly adjusted.	a. Check load resistance against suggested feedback signal terminal hook-up b. Check line voltage at CPS-5 transformer terminals 1 and 3. Check CPS-5 voltage at resistor. Check CPS-5 power supply voltage across capacitors C8 (13 V, except -05.15 V), C9 (15 V), C10 and C11 (28 V). c. Reset CPS-5 rotor position. d. Refer to factory.
22. CPS-5 out of calibration.	a. CPS-5 zero potentiometer inadvertently reset.	a. Refer to factory.
23. CPS-5 signal will not calibrate down to 4 mA.	a. Not enough load on meter circuit. b. Unit being calibrated for less than 80° rotation.	a. Connect 200 ohm resistor in series with meter. b. Remove R8.
24. Actuator does not stay in place with power off.	a. SLM friction surface worn.	a. Replace SLM friction surface.
25. Control motor runs but output shaft does not move in one or both directions.	a. SLM failure.	a. Replace control motor.
26. Actuator equipped with modulating option 5 or 6 and an optional relay board does not run reliably in one or both directions while in AUTO.	a. Controller output requires a greater holding current than the relay board draws.	a. Check the controller output required AC holding current. If greater than 10 mA, additional load must be provided.

APPENDIX Spare Parts & Components

RECOMMENDED SPARE PARTS

It is recommended that certain replacement parts be stocked for quick availability in the event that service of your Beck control actuator is required. The types of parts are listed in Table 5, below.

HOW TO ORDER SPARE PARTS

Select the needed spare parts from Table 5, below. Specify the actuator's model / serial number (example: 14-108-031891-01-02) given on the nameplate to allow the factory to verify the part selection. Parts may be ordered by mail, telephone or fax, with the confirming order sent to the factory (see back cover).

TABLE 5: COMMON RECOMMENDED SPARE PARTS

Description	Part Number	Description	Part Number
ESR-5 board (option 7 & 8 only)	See Table 3, p. 15	Limit switch assy. (RET / EXT)	20-3202-20
Fuse, 6A, 250V	13-2230-03	Auxiliary switch assy. 2 switches (S1-S2)	20-3202-21
Fuse, 0.8A, 250V (14-10_, 240V)	11-1370-16	4 switches (S1-S4)	20-3202-22
Fuse, 2.5A, 250V (14-20_, 240V)	11-1370-17	SLM Rebuild Kit	See Table 4, p. 34
CPS-5 assembly (option 6 & 8 only)	See Table 2, p. 8	Film potentiometer (option 5 & 7 only)	20-3060-03
Control motor	See Table 6, below	Stall Protection Module	20-2901-06
Motor resistor	See Table 6, below	Gasket kit	20-3110-13
Motor capacitor	See Table 6, below		

TABLE 6: MOTORS, CAPACITORS AND RESISTORS

Model No.	Motor					Capacitor		Resistor		Use Only With Timing ...
	Part No.	Current (Amps at 120 V ac, 60 Hz ^c)	Torque (N•m)	RPM	Freq. (Hz)	Part No.	Value (µf)	Part No.	Value (Ω)	
14-100	20-2702-31	.44	1.5	72	60	14-2840-16	5	20-1971-13	220	10 sec. or higher
					50	14-2840-19	7	20-1971-13	220	10 sec. or higher
	20-2703-31	.72	3.0	72	60	14-2840-05	8	20-1971-12	110	10 sec. or higher
					50	14-2840-30	13	20-1971-12	110	10 sec. or higher
	20-2703-34*	.72	3.0	72	60	14-2840-05	8	20-1971-12	110	8 sec. or higher
					50	14-2840-30	13	20-1971-12	110	8 sec. or higher
14-200	20-2703-35	1.2	6.0	72	60	14-2840-17	15	20-1971-11	55	All
					50	14-2840-17	15	20-1971-11	55	All
						14-2840-09	6			

*Note: It is necessary to install a gear housing spacer with this module.

TABLE 7: GEARS

MODEL NO.	SPUR GEAR RATIO / 1	NOMINAL SPEED sec./in. (sec./cm)		GEAR HOUSING ASSEMBLY
		60 Hz 72 RPM	50 Hz 60 RPM	
14-100	4.14	4 (1.6)	5 (2.0)	10-6670-36
	7.90	8 (3.1)	10 (3.9)	10-6670-26
	10.65	11 (4.3)	13 (5.1)	10-6670-24
	15.70	16 (6.3)	19 (7.5)	10-6670-13
	25.90	27 (10.6)	31 (12.2)	10-6670-23
	45.80	48 (18.9)	57 (22.4)	10-6670-07
14-200	15.61	16 (6.3)	20 (7.9)	10-6670-54
	22.86	24 (9.4)	29 (11.4)	10-6670-55

APPENDIX Control Assembly

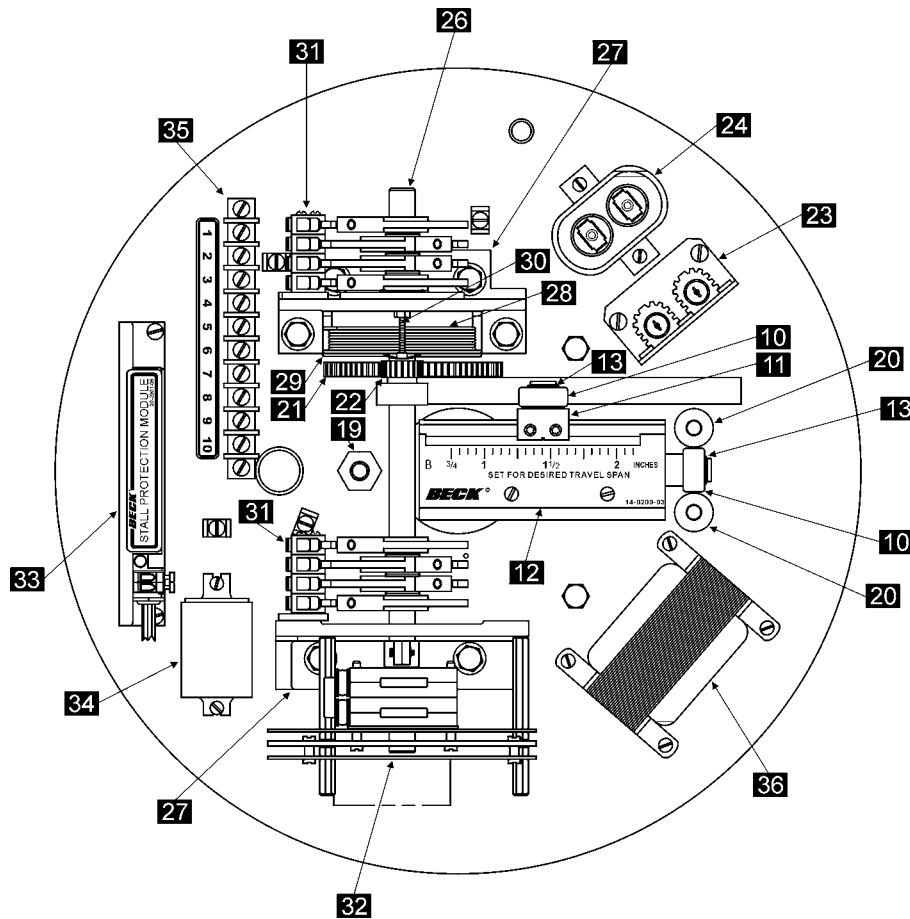

**TABLE 8:
PARTS FOR MODEL 14-100 CONTROL ASSEMBLY AND DRIVE TRAIN**

ITEM NO.	DESCRIPTION	ITEM NO.	DESCRIPTION
1	Top bearing plate with bushing and seals	19	Hex stud
2	Seal for top bearing plate	20	Guide bar (2)
3	Bottom bearing plate with bushing and seals	21	Sector-level gear assembly
4	Seal for bottom bearing plate	22	Pinion
5	Main gear assembly	23	Resistor; select from Table 6
6	Mainshaft bearing	24	Capacitor; select from Table 6
7	Cover plate	25	Tight-sealer
8	Cover plate gasket	26	Shaft
9	Shaft assembly	27	Bracket (2)
10	Ball bearing (2)	28	Spring
11	Calibar slider	29	Mandrel
12	Calibar index	30	Switch shaft indicator
13	Retaining ring (2)	31	Switches; see Table 5
14	Motor assembly; select from Table 6 (sold only as complete assembly)	32	CPS or film potentiometer
15	Gear housing assembly; select from Table 7 (sold only as complete assembly)	33	Stall Protection Module (SPM) (optional)
16	Top cover with gasket	34	Double-pole, double-throw relay (optional)
17	Top cover bolt	35	Auxiliary terminal strip
18	Top bar	36	Transformer (w/ fuse, if 240V model)

Note: To ensure exact replacement parts, include all nameplate data of the Beck actuator with the order.

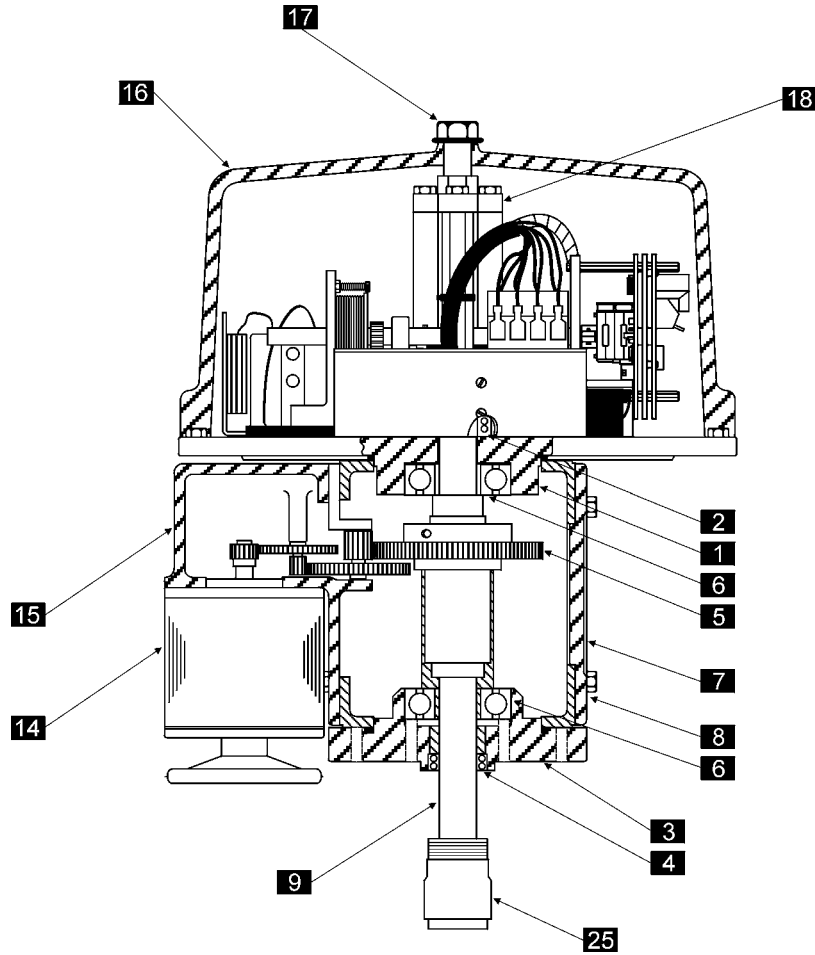

CONTROL ASSEMBLY AND DRIVE TRAIN

APPENDIX Control Assembly

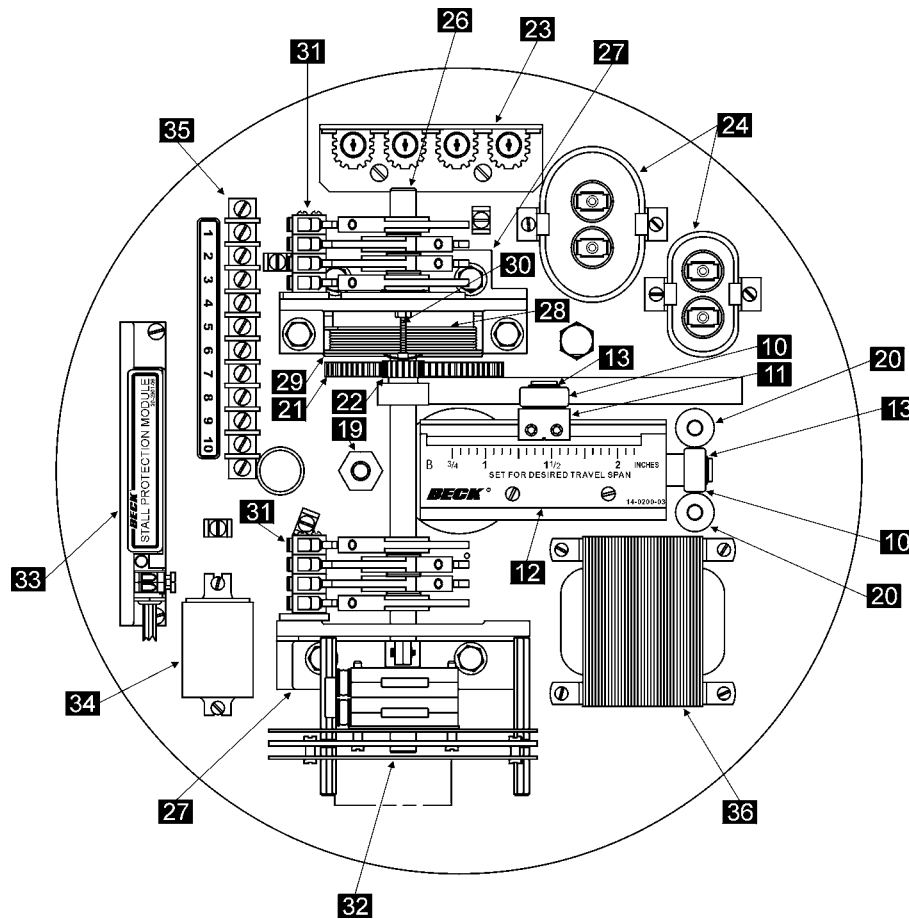

**TABLE 9:
PARTS FOR MODEL 14-200 CONTROL ASSEMBLY AND DRIVE TRAIN**

ITEM NO.	DESCRIPTION	ITEM NO.	DESCRIPTION
1	Top bearing plate with bushing and seals	19	Hex stud
2	Seal for top bearing plate	20	Guide bar (2)
3	Bottom bearing plate with bushing and seals	21	Sector-level gear assembly
4	Seal for bottom bearing plate	22	Pinion
5	Maingear assembly	23	Resistor; select from Table 6
6	Mainshaft bearing	24	Capacitor; select from Table 6
7	Cover plate	25	Tight-sealer
8	Cover plate gasket	26	Shaft
9	Shaft assembly	27	Bracket (2)
10	Ball bearing (2)	28	Spring
11	Calibar slider	29	Mandrel
12	Calibar index	30	Switch shaft indicator
13	Retaining ring (2)	31	Switches; see Table 5
14	Motor assembly; select from Table 6 (sold only as complete assembly)	32	CPS or film potentiometer
15	Gear housing assembly; select from Table 7 (sold only as complete assembly)	33	Stall Protection Module (SPM) (optional)
16	Top cover with gasket	34	Double-pole, double-throw relay (optional)
17	Top cover bolt	35	Auxiliary terminal strip
18	Top bar	36	Transformer (w/ fuse, if 240V model)

Note: To ensure exact replacement parts, include all nameplate data of the Beck actuator with the order.

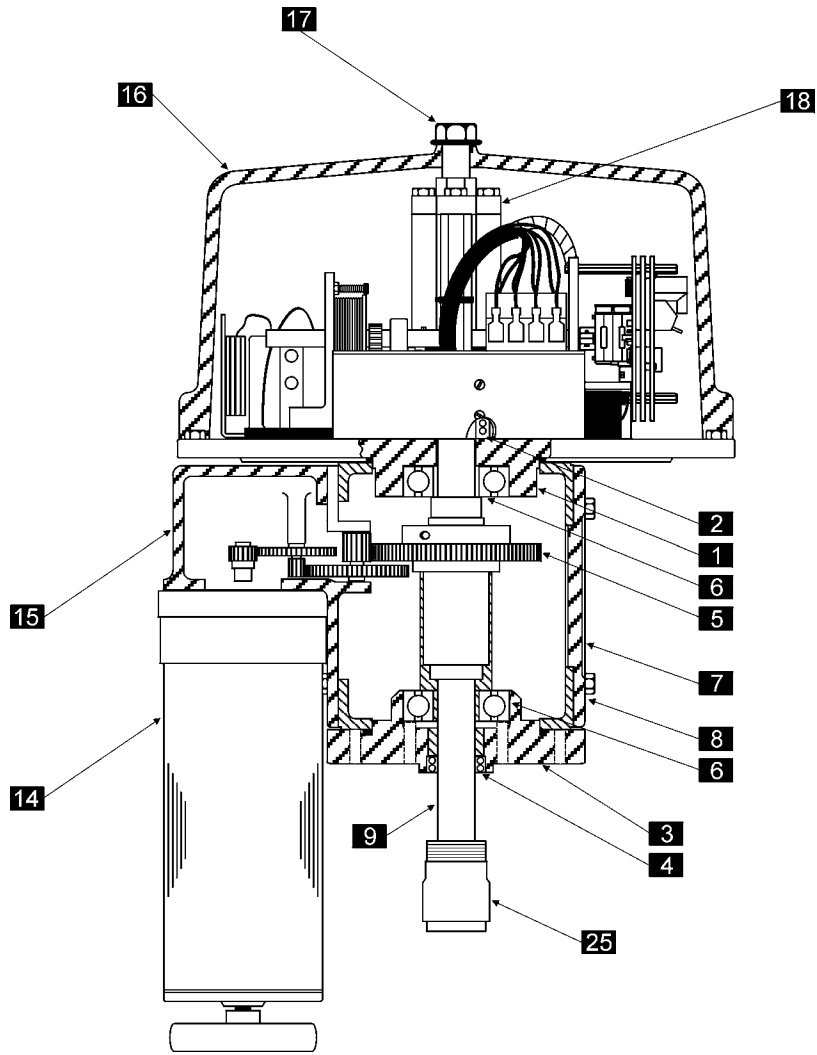

CONTROL ASSEMBLY AND DRIVE TRAIN

APPENDIX CPS-5 Data & Functional Block Diagram

TABLE 10: CPS-5 SYSTEM APPLICATION DATA SUMMARY

FEEDBACK SIGNAL OPTIONS	CPS-5 MODEL NO.	EXTERNAL LOAD RESISTANCE	COMPATIBLE CONTROL SYSTEMS
<u>Current Signals</u>			
4 to 20 mA	20-4400-02 & -12	800Ω (Max.)	Industry Std (ISA)
10 to 50 mA	20-4400-03 & -13†	500Ω (Max.)	Foxboro
1 to 5 mA	20-4400-03 & -13†	2KΩ (Max.)	General Use
<u>Voltage Signals</u>			
1 to 5 V DC	20-4400-03 & -13†	250Ω (Min.)	Industry Std (ISA) Beck Position-All (27-301,-401,-501)
0 to 5 V DC	20-4400-03 & -13†	250Ω (Min.)	Leeds and Northrup
0 to 10 V DC	20-4400-03 & -13†	1KΩ (Min.)	Bailey, Foxboro, & Westinghouse
0 to 16 V DC	20-4400-03 & -13†	1KΩ (Min.)	Leeds and Northrup

†The 20-4400-03 and -13 may be connected for signal ranges so noted. See Wiring Diagrams on pages 13–14.

TABLE 11: CPS-5 SIGNAL OUTPUT TERMINAL CONNECTIONS AND LOADING

SIGNAL RANGE	OUTPUT TERMINALS (+) (-)	RANGING RESISTOR		RESISTOR CONNECTIONS	MAXIMUM EXTERNAL LOAD
		VALUE	BECK PART NO.		
Models 20-4400-02, -12					
4 to 20 mA	EE—CC	Open			800Ω
4 to 20 mA	EE—DD	Open			500Ω
Models 20-4400-03, -13					
<u>Current Output</u>					
0 to 4 mA*	DD—CC	Open			2 KΩ
1 to 5 mA	DD—CC	Open			2 KΩ
4 to 20 mA	DD—CC	332Ω	13-2511-06	DD—EE	500Ω
10 to 50 mA	DD—CC	110Ω	13-2510-25	DD—EE	200Ω
<u>Voltage Output</u>					
0 to 4 V dc*	EE—CC	Jumper			16 mA
0 to 5 V dc*	EE—CC	249Ω	13-2511-08	CC—DD	16 mA
0 to 10 V dc*	EE—CC	1.5 KΩ	13-2512-02	CC—DD	16 mA
0 to 15 V dc*	EE—CC	2.74 KΩ	13-2513-42	CC—DD	16 mA
1 to 5 V dc	EE—CC	Jumper		CC—DD	16 mA
2 to 10 V dc	EE—CC	1.00 KΩ	13-2512-01	CC—DD	16 mA
0 to 16 V dc*	EE—CC	3.01 KΩ	13-2513-26	CC—DD	16 mA

*If factory set for 4–20 mA, zero potentiometer adjustment is required after installation. See page 31.

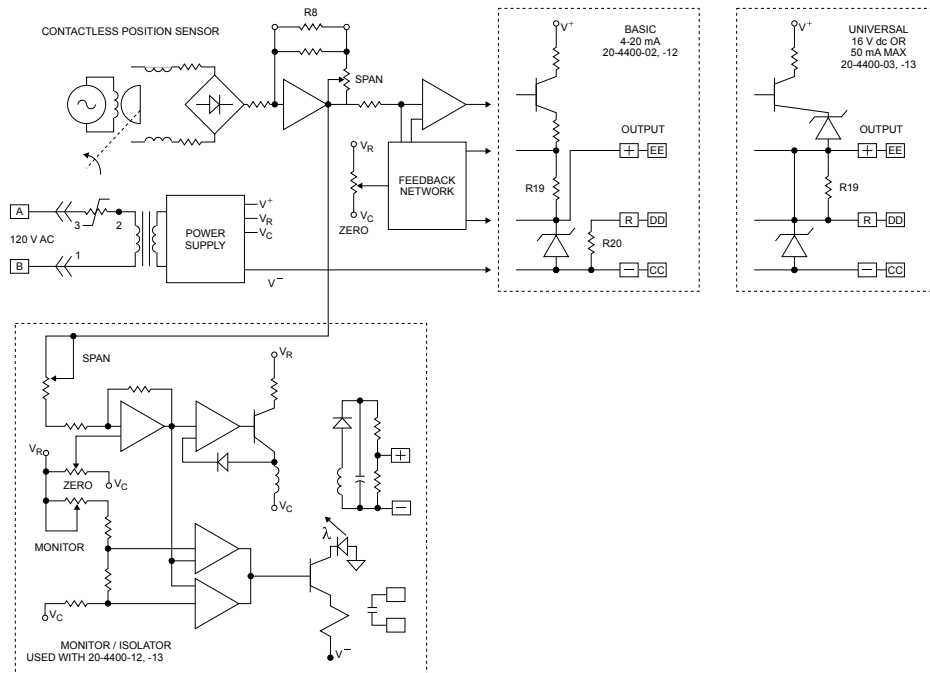

APPENDIX Schematics

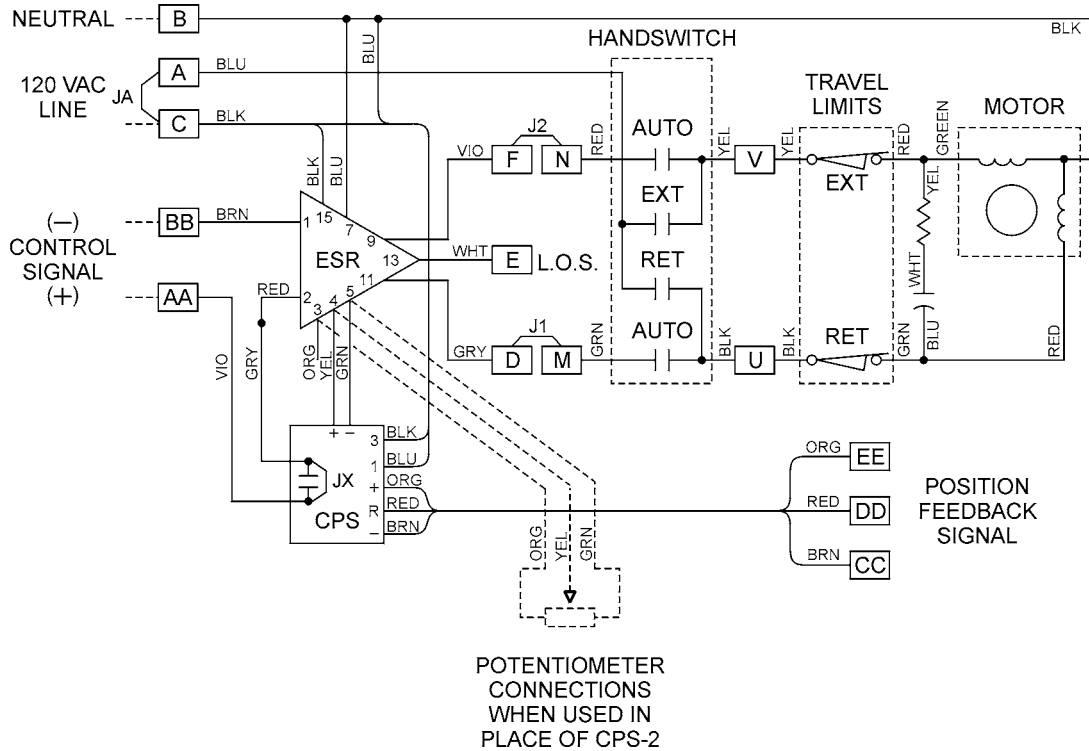

TYPICAL SCHEMATIC FOR CONTROL OPTION 7 OR 8

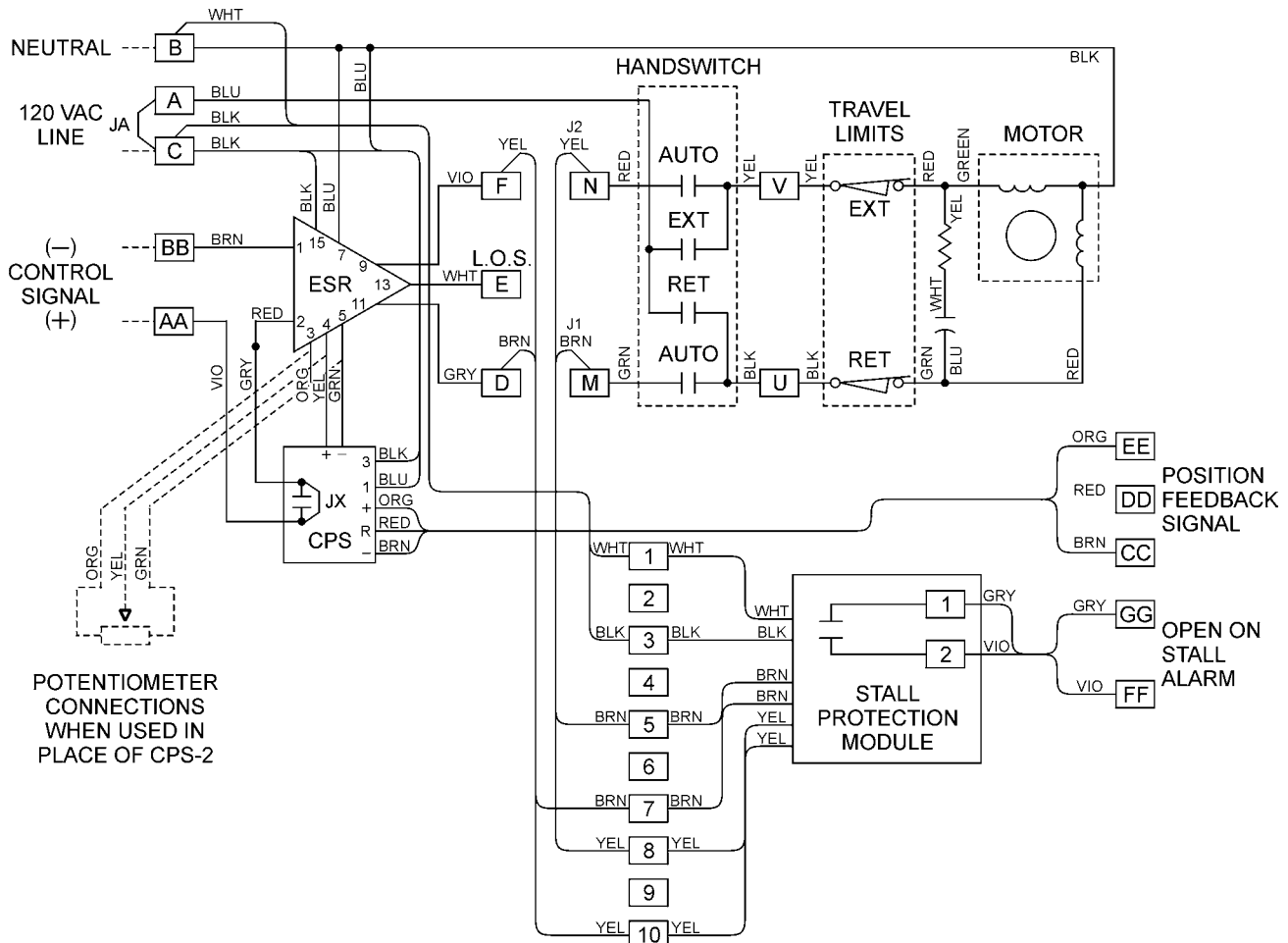

TYPICAL SCHEMATIC FOR CONTROL OPTION 7 OR 8 W/ STALL PROTECTION MODULE

INDEX

Adjusting the zero potentiometer.....	27	Motor, replacement.....	33
Application reviews.....	47	Motor resistor and capacitor, replacement	33
Applications, typical.....	4	Mounting actuator on valve	9
Calibar adjustment.....	23	Outline dimension drawings	6–7
CPS-5 calibration.....	26	Parallel operation.....	15
CPS-5 functional block diagram	44	Patents	47
CPS-5 output terminal connections and loading.....	44	Position feedback	20
CPS-5 replacement	35	Product demonstrations.....	47
CPS-5 system application data summary.....	44	SLM	34
CPS-5 signal connections	13	Safety precautions.....	9
Changing direction of travel.....	24	Seal replacement.....	33
Contactless Position Sensor (CPS-5).....	20	Series operation	15
Control motor.....	18	Service, how to obtain	47
Control options	8, 19	Signal monitor sensing	27
Deadband (gain) adjustment	31	Site surveys	47
Drive train	40–43	Span	31
ESR-5 board replacement.....	35	Spare parts, recommended	39
Feedback signal calibration.....	26	Specification writing.....	47
Feedback signal monitor / isolator.....	27	Split range operation	16
Film potentiometer.....	20	Start-up instructions.....	17
Film potentiometer calibration	25	Storage information	9
Filter adjustment.....	31	Switch adjustments.....	21
Gaskets, replacement.....	33	Switches	19
Gear components	39	Switches, adding / replacement.....	34
General description	4	Table of contents	3
General specifications	5	Tight-Seater™	18
Handswitch.....	19	Troubleshooting.....	36–38
Handswitch, replacement	35	Unpacking.....	9
Handwheel.....	19		
Housing	18		
Demand signal range change	15		
Demand signal calibration	29		
Demand signal options	15		
Installation	9		
Introduction.....	2		
Limit and auxiliary switch replacement.....	34		
Loss of signal.....	20		
Lubrication	32		
Maintenance	32		
Component replacement.....	33		
Routine.....	32		

SERVICES

PRODUCT DEMONSTRATIONS

Each of Beck's Sales Engineers has access to a complete set of actuator models so that he can demonstrate virtually any of their features at your location. In order to arrange to see a Beck actuator in your plant or office, contact Beck's Sales Department.

SITE SURVEYS

Beck Sales Engineers are available to discuss your process control requirements. Often a visit to your location is the best way to gain a thorough understanding of your needs, in order to meet them most accurately and completely.

Mounting hardware, torque requirements, linkage, control signal information, and optional equipment can be analyzed most effectively at the worksite. Beck's analysis at the jobsite can help ensure that specifications are accurate, especially in the case of complex applications.

APPLICATION REVIEWS

By sharing your needs with a Beck Sales Engineer you can take advantage of the best application advice for the type of control you need. This review will yield a better understanding of the versatility of Beck actuators for your installations, as well as complete details on options and accessories to make the process as effective as possible.

SPECIFICATION WRITING

Beck provides specification writing assistance in order to help you specify and order the right actuators for your applications. Beck Sales Engineers will work with you to make it easier for you to obtain the proper equipment and give you confidence that no details are overlooked.

HOW TO OBTAIN SERVICE

Factory repair of actuators or subassemblies is available for both normal and emergency service. To assure prompt processing, identify the material with your company name, billing and shipping addresses, and a purchase order number. If a repair estimation is desired, please send the name and phone number of your contact for service authorization. It is helpful to include a description of the work desired with the shipment or, in the event of a problem, the malfunction being experienced.

WARRANTY STATEMENT*

The Seller warrants that the equipment sold hereunder shall conform to Seller's standard specifications. The Seller warrants said equipment to be free from defects in materials and workmanship. This warranty applies to normal recommended use and service for one year from the date on which the equipment is shipped. The Seller's obligation under this warranty, and Buyer's exclusive remedy, will be the repair or replacement, without charge, at the Seller's factory, of any defective equipment covered by this warranty. In no event will the Seller's liability exceed the contract price for the goods claimed to be defective.

THIS WARRANTY IS EXPRESSLY IN LIEU OF ANY OTHER EXPRESS OR IMPLIED WARRANTY, INCLUDING IMPLIED WARRANTIES OR MERCHANTABILITY AND FITNESS FOR A PARTICULAR PURPOSE, AND ALL OTHER OBLIGATIONS OR LIABILITIES OF THE SELLER INCLUDING INCIDENTAL, SPECIAL, OR CONSEQUENTIAL DAMAGES.

Buyer acknowledges its responsibility under OSHA, related laws and regulations and other safety laws, regulations, standards, practices or recommendations which are principally directed to the use of equipment in its operating environment. Buyer acknowledges that the conditions under which such equipment will be used, its use or combination with, or proximity to, other equipment, and other circumstances of the operation of such equipment are matters beyond Seller's control. BUYER HEREBY AGREES TO INDEMNIFY SELLER AGAINST ALL CLAIMS, DAMAGES, COSTS OR LIABILITIES (INCLUDING, BUT NOT LIMITED TO, ATTORNEYS' FEES AND OTHER LEGAL EXPENSES), WHETHER ON ACCOUNT OF NEGLIGENCE OR OTHERWISE, EXCEPT THOSE CLAIMS BASED SOLELY UPON THE NEGLIGENCE OF SELLER AND THOSE CLAIMS ASSERTED BY SELLER'S EMPLOYEES WHICH ARISE OUT OF OR RESULT FROM THE OPERATION OR USE OF THE EQUIPMENT BY SELLER'S EMPLOYEES.

***Note: Internal water damage is not covered by warranty.**

© Copyright 2013 by Harold Beck & Sons, Inc.

Beck Actuators are covered by the following patents: 6,563,412 and 6,639,375.



BECK[®] **HAROLD BECK & SONS, INC.**

Made in USA 

11 TERRY DRIVE • NEWTOWN, PENNSYLVANIA 18940 • USA
PHONE: 215-968-4600 • FAX: 215-860-6383 • E-MAIL: sales@haroldbeck.com
www.haroldbeck.com