

80-4280-02  
Rev. 04.1

**MODELS 22-309  
22-409  
22-809**

***BECK***<sup>®</sup>

# INSTRUCTION MANUAL

---

---



**CE**<sub>08</sub>



**ELECTRIC ACTUATORS FOR INDUSTRIAL PROCESS CONTROL**

# INTRODUCTION TO THE MANUAL

This manual contains the information needed to install, operate, and maintain Beck Model Group 22 Electronic Control Drives, manufactured by Harold Beck & Sons, Inc. of Newtown, Pennsylvania.

The Group 22 drives are powerful control packages designed to provide precise position control of dampers and other devices requiring up to 8,000 lb-ft (10 846 N•m) drive torque.

**NOTICE:** This manual includes information that will make installation simple, efficient, and trouble-free. Please read and understand the appropriate sections in this manual before attempting to install or operate your drive.



The Group 22 control drive was developed to fulfill an industry need for accurate, reliable, digital control in high torque applications. The drive is ideal for use in large boiler applications, such as ID/FD fan dampers.

The Group 22 offers the excellent performance and maintenance-free design typical of Beck drives; plus the added flexibility and features provided by microprocessor-based electronics. Beck's full product line is shown below. Contact a Beck Sales Engineer for assistance with specific applications.

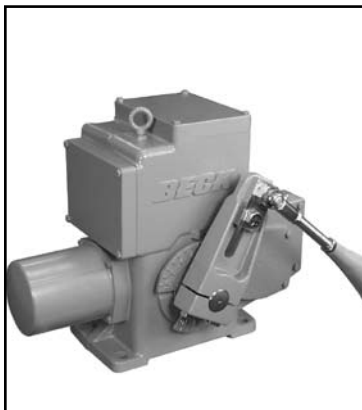

**Group 11 rotary drives ...** provide precise position control of dampers, quarter-turn valves, fluid couplings, and other devices requiring up to 1,800 lb-ft (2 440 N•m) drive torque.



**Group 11 quarter-turn drives ...** are designed specifically for use with ball, plug, and butterfly valves. Direct-coupled, factory-mounted assemblies are available from Beck for easy installation.



**Group 14 linear drives ...** are ideally suited for globe valves from 1" to 8" (25 mm to 203 mm) diameter. Beck's unique "Tight-Seater™" coupling provides positive seating of valves.



**Group 31 rotary drives ...** are particularly suited for coupling to ball, plug, and butterfly valves up to 4" (102 mm) diameter, and small dampers.

# CONTENTS

<b>Product Description</b> .....	4
General Specifications .....	6
<b>Outline Dimension Drawings</b> .....	8
<b>Installation</b> .....	12
Linkage .....	14
Wiring .....	16
Start-up .....	22
<b>Configuration &amp; Setup</b> .....	23
Switches .....	24
<b>Digital Control Module (DCM<sup>®</sup>) Configuration &amp; Setup (General)</b> .....	26
<b>Digital Control Module-HART<sup>®</sup> Compatible (DCM-H) Configuration &amp; Setup (Specific)</b> .....	27
<b>DCM-H Calibration</b> .....	32
Range Selection .....	32
Signals .....	34
<b>DCM-H Communication</b> .....	35
<b>Digital Control Module-Local Customer Interface (DCM-L) Configuration &amp; Setup (Specific)</b> ....	45
<b>DCM-L Calibration</b> .....	48
Demand .....	48
Position .....	50
Direction Change .....	51
<b>Maintenance</b> .....	52
<b>Appendix</b>	
Serial Commands .....	54
<b>Model 275 Handheld Communicator Menu Structure</b> .....	64
<b>Services</b> .....	67

# PRODUCT DESCRIPTION

The Beck Group 22 control drive offers the excellent performance and maintenance-free design typical of Beck drives; plus the added flexibility and features provided by microprocessor-based electronics.

Ideally suited for large fan damper applications, the Group 22 is capable of modulating both static and dynamic loads up to 8,000 lb-ft (10 846 N•m) of torque, even in the harshest of environments. Installation is simplified due to a compact, weatherproof body design, which houses all the components, including the sophisticated control package.

The Beck control motor is specially designed to work with the drive's on-board control electronics. The motor will not coast or over-shoot, and will not overheat, even under continuous modulation. Beck motors have double grease-sealed bearings and require no maintenance.

The Group 22 utilizes a high-efficiency gear train designed for long life and minimal wear. The precision-cut spur gears are fabricated from heat-treated alloy steel and ductile iron.

An easy to turn, spoke-free Handwheel or Handcrank mechanism (model 22-809 only) is

incorporated into the design of the Group 22 drives to allow manual operation during installation or power outages. These devices can be used to precisely modulate dampers, even under full load conditions.

Dampers may also be operated at their individual locations with a built-in electric Handswitch.

For ease of installation on any application, the heavy duty crank arm can be easily positioned to start anywhere in the full 360° rotation of the output shaft. To further facilitate proper installation and setup, the crank arm radius is easily adjustable through a wide range of values.

Beck electronic control drives have individual cast aluminum compartments for each of the main components: The control motor, wiring terminal block(s), Digital Control Module (DCM<sup>®</sup>), and position sensing device. Gasketed covers and sealed shafts make the drives suitable for outdoor and high humidity environments. Drives should only be operated with the covers properly in place and secured.

Heavy, cast mechanical stops built into the housing are designed to prevent over-travel damage.

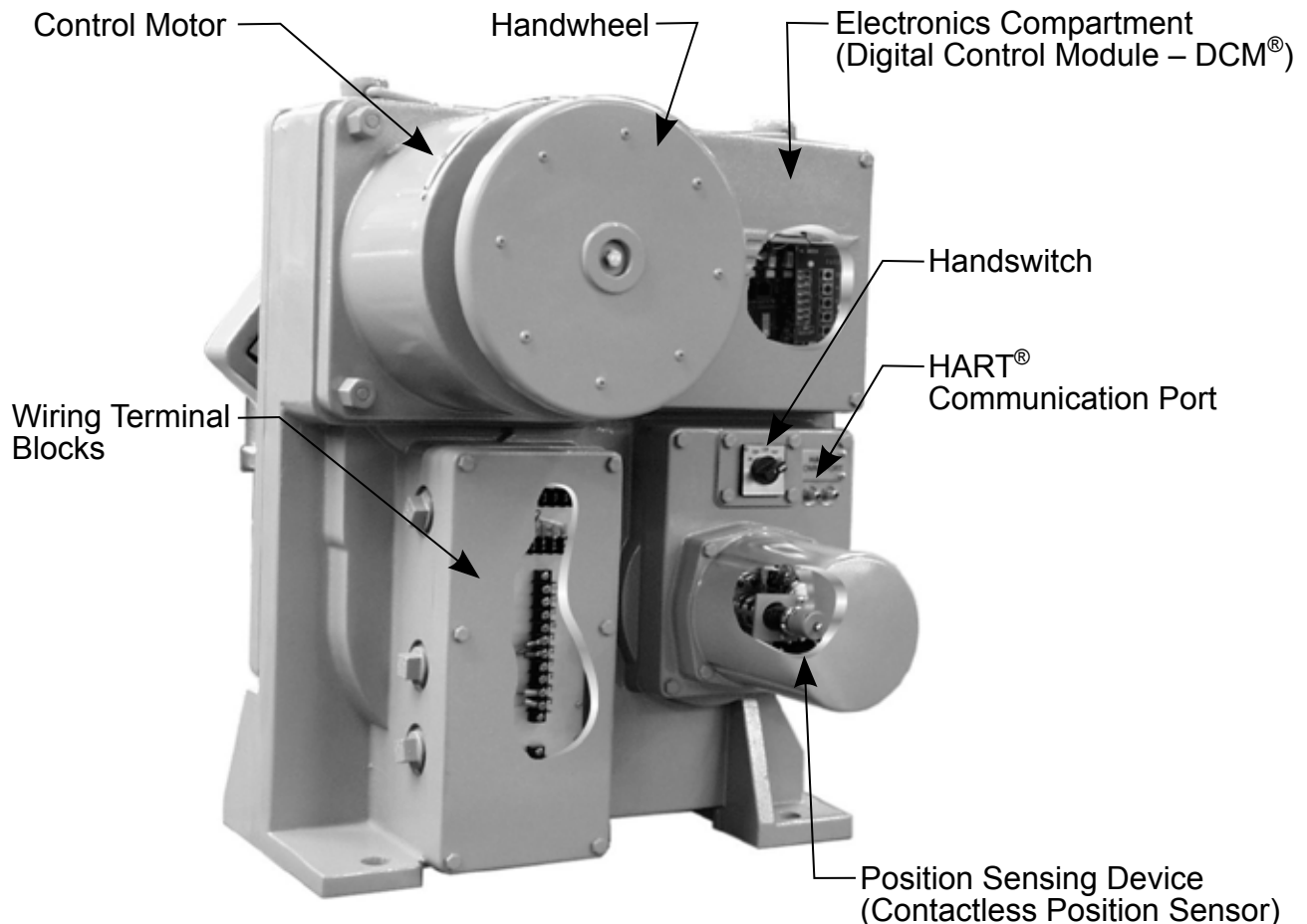

(MODEL 22-309 SHOWN)

## CONTROL & OPERATING FEATURES

In addition to drive control, the microprocessor-based electronics provide a host of features and functions. Some of the advanced features include:

- Error-based variable speed operation for precise positioning performance.
- Compatible with common asset management systems.
- Two-way digital communications via HART® protocol or RS-232 serial connection.
- Simplified calibration without any mechanical or electrical adjustment.
- Drive diagnostics and operating statistics available locally or remotely.
- Easy configuration, setup and documentation of drive operating parameters.
- Live torque measurement and overtorque protection.
- Stall protection with configurable stall time setting.
- The choice of linear or square input signal characterization.
- All operating parameters including temperature can be displayed via HART.
- Configurable action on loss of demand input signal.
- Read/write parameters including tag and descriptor information, last calibration date, and model and serial numbers are saved on board.
- Ability to restore all drive calibration and setup information to the factory “as-built” configuration.

## BECK LINKAGE KITS

Beck pipe linkage kits are available for completing the mechanical connection from the drive crank arm to the load. Through the use of a standardized selection, the linkage can be ordered even if the exact length is not determined until the drive and driven device are installed.

All Beck Group 22 drives are furnished with a crank arm and rod end (see pages 8–11 for dimensions). All rod ends furnished by Beck incorporate bearings to accommodate some lateral misalignment. Once the connection is made, linkage kits can be adjusted  $\pm 1 \frac{1}{2}$ " (38 mm) without removal of the crank arm or load lever, making final mechanical calibration simple.



# PRODUCT DESCRIPTION

## 22-309, 22-409 & 22-809 GENERAL SPECIFICATIONS

### Output Torque and Timing

22-309	3,000 lb-ft (4 067 N•m), 30–300 (configurable) sec./100°
22-409	4,000 lb-ft (5 423 N•m), 15–300 (configurable) sec./100°
22-809	8,000 lb-ft (10 846 N•m), 15–300 (configurable) sec./100°

### Drive Current Rating in Amps (listed by operating voltage)\*

Model No.	Operating Voltage (Volts AC)							
	1 - phase		3 - phase					
	120	240	208	240	380	416	480	575
22-309	6.0	3.0	3.5	3.0	1.9	1.7	1.5	1.3
22-409	N/A	N/A	4.0	3.5	2.2	2.0	1.7	1.4
22-809	N/A	N/A	6.9	6.0	3.8	3.5	3.0	2.5

\*Operating voltage tolerance is +10% to -15%. All models may be operated at 60 Hz or 50 Hz frequency.

= Current rating for the standard operating voltage configuration. Other operating voltages for the 22-309 & 22-409 are available with an optional transformer.

### Weight

22-309	515 lbs. (234 kg), depending on selected options.
22-409	515 lbs. (234 kg)
22-809	1,250 lbs. (567 kg)

### Operating Conditions

-40° to 85°C (-40° to 185°F)  
0 to 99% relative humidity

### Communication Interface

HART protocol or local pushbutton/LED panel and RS-232 Serial commands.

### Demand Input Signal Range

4–20 mA, 1–5 V dc

### Minimum Step

0.1° typical

### Hysteresis

0.25% of span at any point.

### Demand Input Signal Characterization

Linear: Drive output shaft moves proportionally to the input signal.  
Square: Drive output shaft moves proportionally to the square of the input signal.

### Position Feedback Signal

4–20 mA

### Isolation

Demand input and position Feedback signals are isolated from ground and the ac power line. Signal buffering provides 24 V dc isolation between the Demand and Feedback signals.

### Action on Loss of Power

Output shaft stays in last position.

### Action on Loss of Input Signal (Power on)

Stays in place or runs to any preset position (configurable).

Overtorque Protection	If the output torque of the drive exceeds 115% of the drive rating, the motor will shut off (feature can be enabled/disabled).
Stall Protection	If the motor tries to run in one direction for more than 300 seconds (configurable from 30 to 300 seconds), the motor will shut off.
Over-travel Protection Switches	Two SPDT, one for CW and one for CCW limit of output shaft travel. Standard switch setting is for 101° of travel.
Non-Dedicated Switches (Field adjustable)	Two SPDT, rated for 1 A, 250 V ac.
Customer Wiring	Terminals accommodate up to 12 AWG (3.31 mm <sup>2</sup> ).
Handswitch	Permits local electrical operation, independent of Demand Input signal.
Handwheel and Handcrank	Provides manual operation without electrical power (Handcrank mechanism is provided with model 22-809 only).
Motor	Does not coast or overshoot and will not overheat, even under continuous modulation.
Gear Train	High efficiency, precision-cut, heat-treated alloy steel and ductile iron spur gears enclosed in, and permanently lubricated by, a grease-filled housing are designed for long life and minimal wear.
Mechanical Stops	Prevent over-travel during automatic or manual operation.
Enclosure	Precision-machined aluminum alloy castings, painted with corrosion-resistant polyurethane paint, provide a rugged, dust-tight, weatherproof enclosure.
Mounting Orientation	Upright, as depicted in outline dimension drawings on pages 8–11.
Standards**	UL Listed CE Compliant

\*\*NOTE: May not be available with all options and models. For more information or to inquire about standards not specifically listed, please call Beck for more information at 215-968-4600.

# OUTLINE DIMENSION DRAWINGS

MODEL 22-309 & 22-409 SPECIFICATIONS  
*All Dimensions in Inches and [mm]*

Mounting orientation  
 should be upright,  
 as depicted.

FRONT VIEW

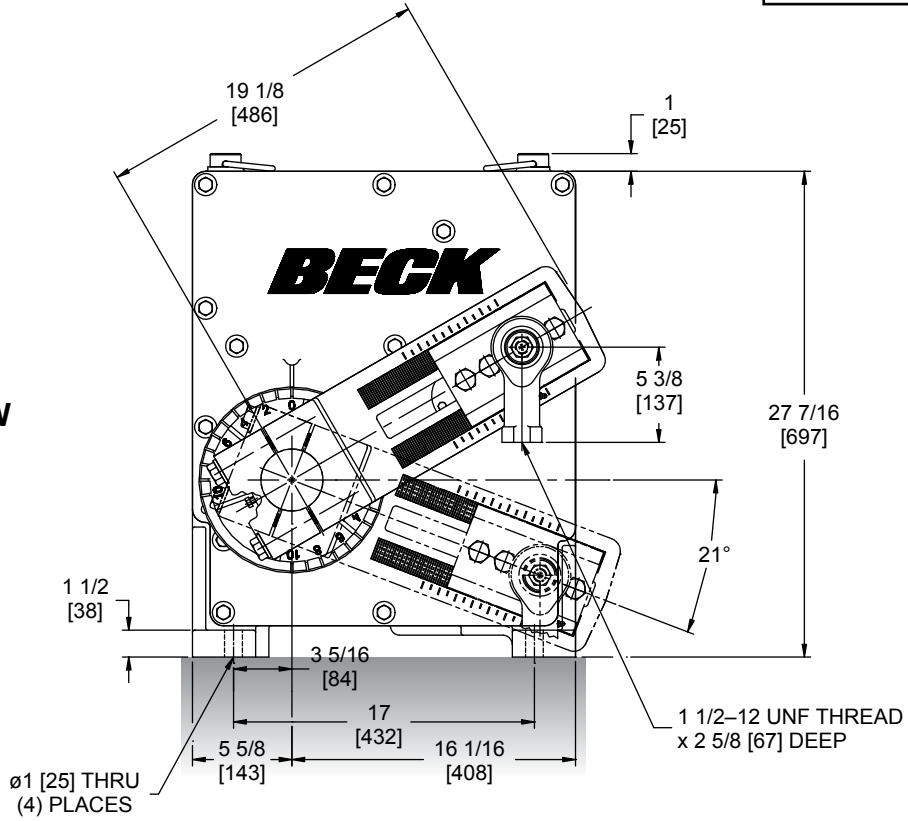

REAR VIEW

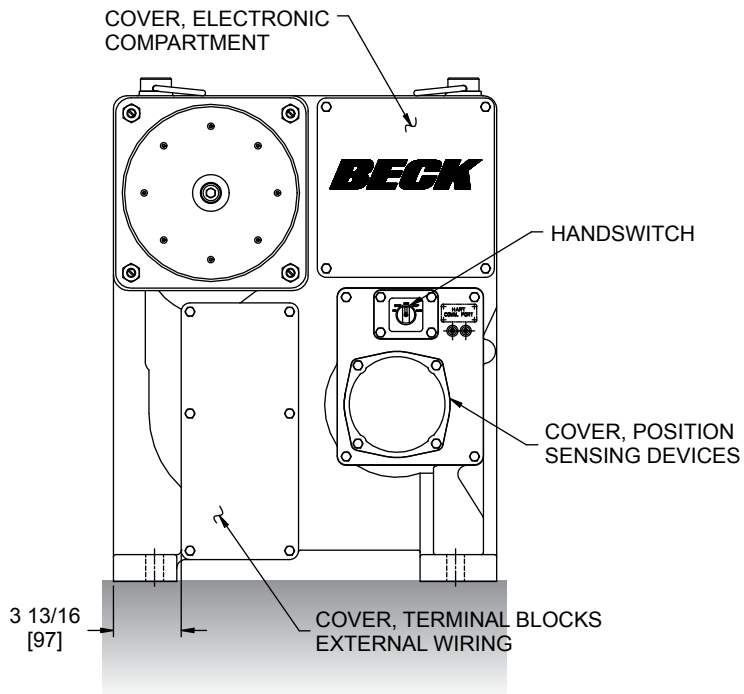



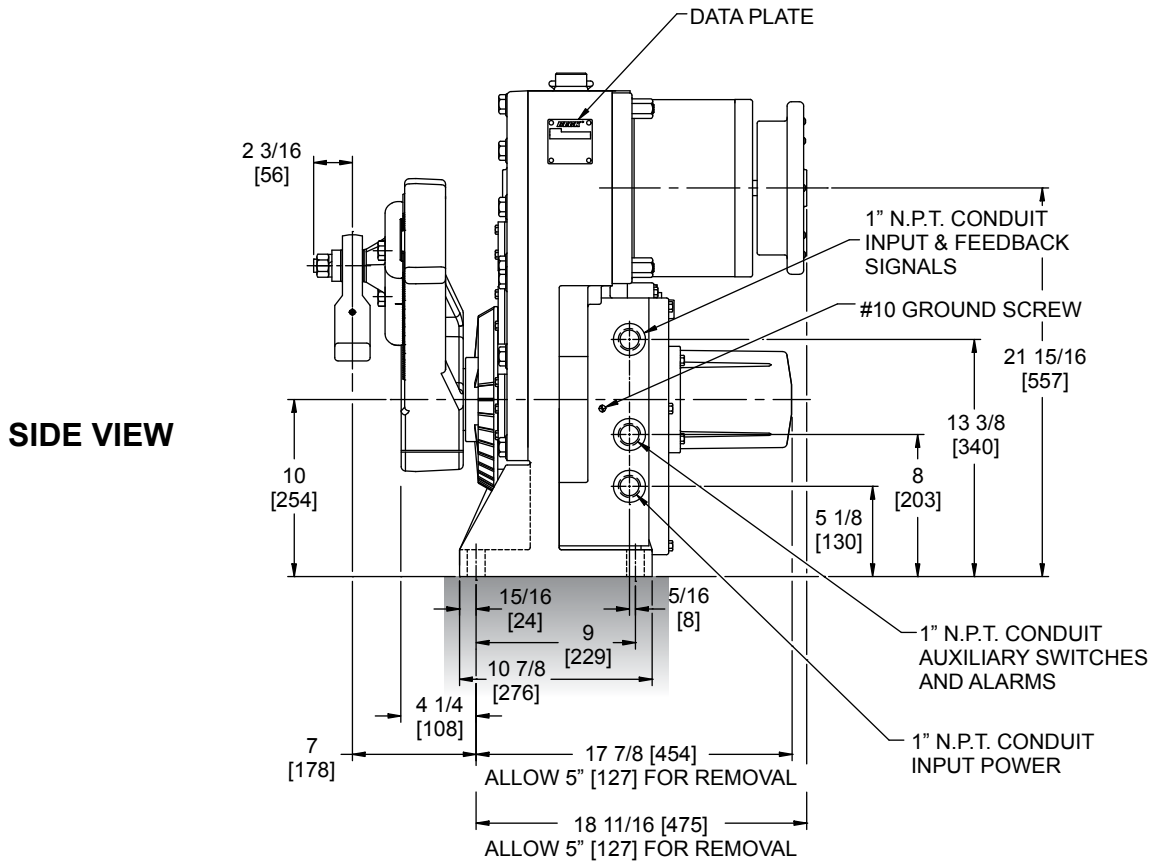

Beck Model No.	Torque (lb-ft)[N•m]	Timing (sec/100°)	Net Wt. (lb)[kg]	Output Shaft Dia. (in)[mm]	Maximum Overhung Load (lb)[kg]
22-309	3,000 [4 067 N•m]	30	515* [234]	3 1/2 [89]	15,000 [6 804]
22-409	4,000 [5 423 N•m]	15	515* [234]	3 1/2 [89]	15,000 [6 804]

\*635 lbs. [289 kgs] with optional transformer

### Fastener Guide

#### CRANK ARM

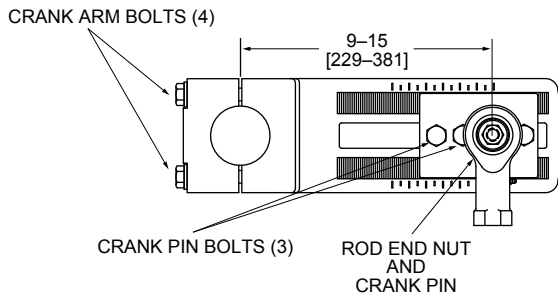

	Thread Size	Torque (lb-ft)[N•m]
Crank Arm Bolts (4)		
22-309	3/4-16	300 [407]
22-409	3/4-16	420 [569]
Rod End Nut (1)	3/4-16	200 [271]
Crank Pin Bolts (3)	3/4-16	300 [407]
Motor Mounting Nuts (4)	1/2-13	37 [50]
Electronics Compartment Cover (4)	5/16-18	10 [14]
Terminal Compartment Cover (6)	5/16-18	10 [14]
Position Sensing Devices Cover (4)	5/16-18	10 [14]
Mounting Bolts (4)	7/8-9	*

\* Torque appropriately for application.

# OUTLINE DIMENSION DRAWINGS

MODEL 22-809 SPECIFICATIONS  
*All Dimensions in Inches and [mm]*

Mounting orientation  
 should be upright,  
 as depicted.

FRONT VIEW

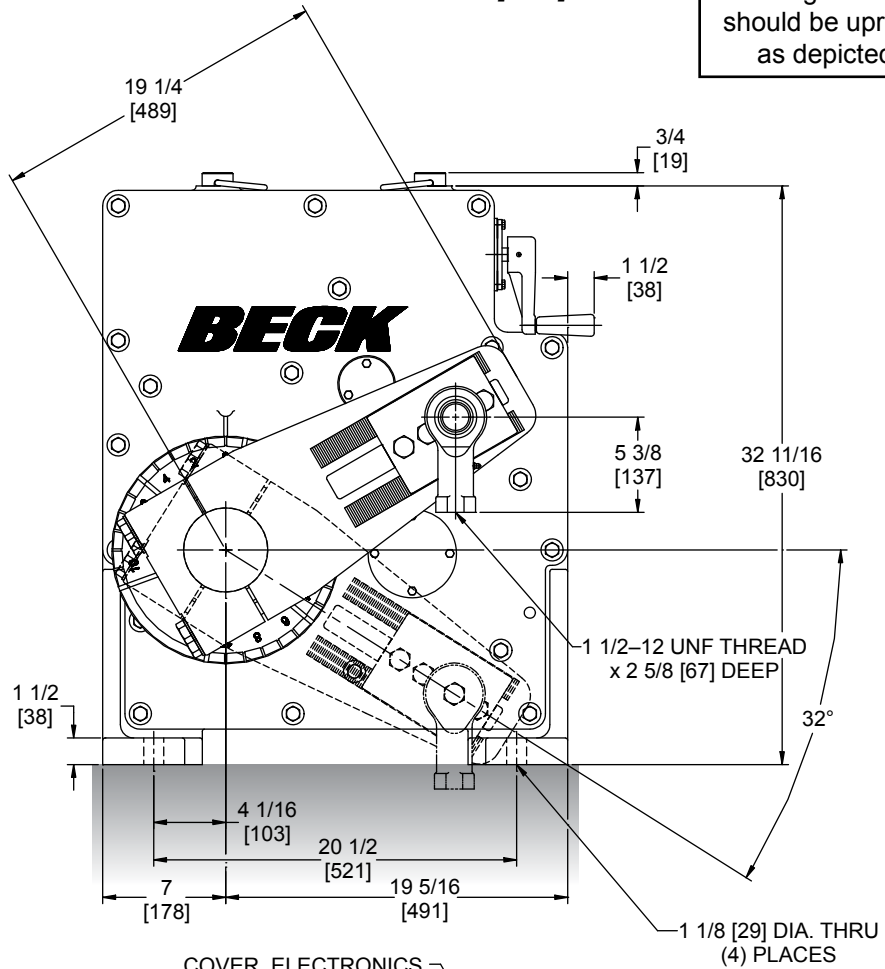

REAR VIEW

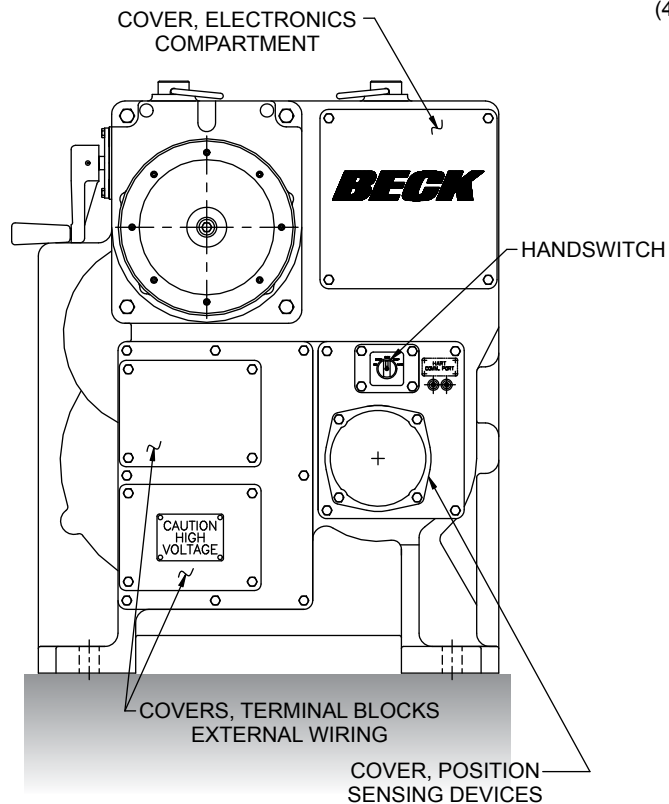

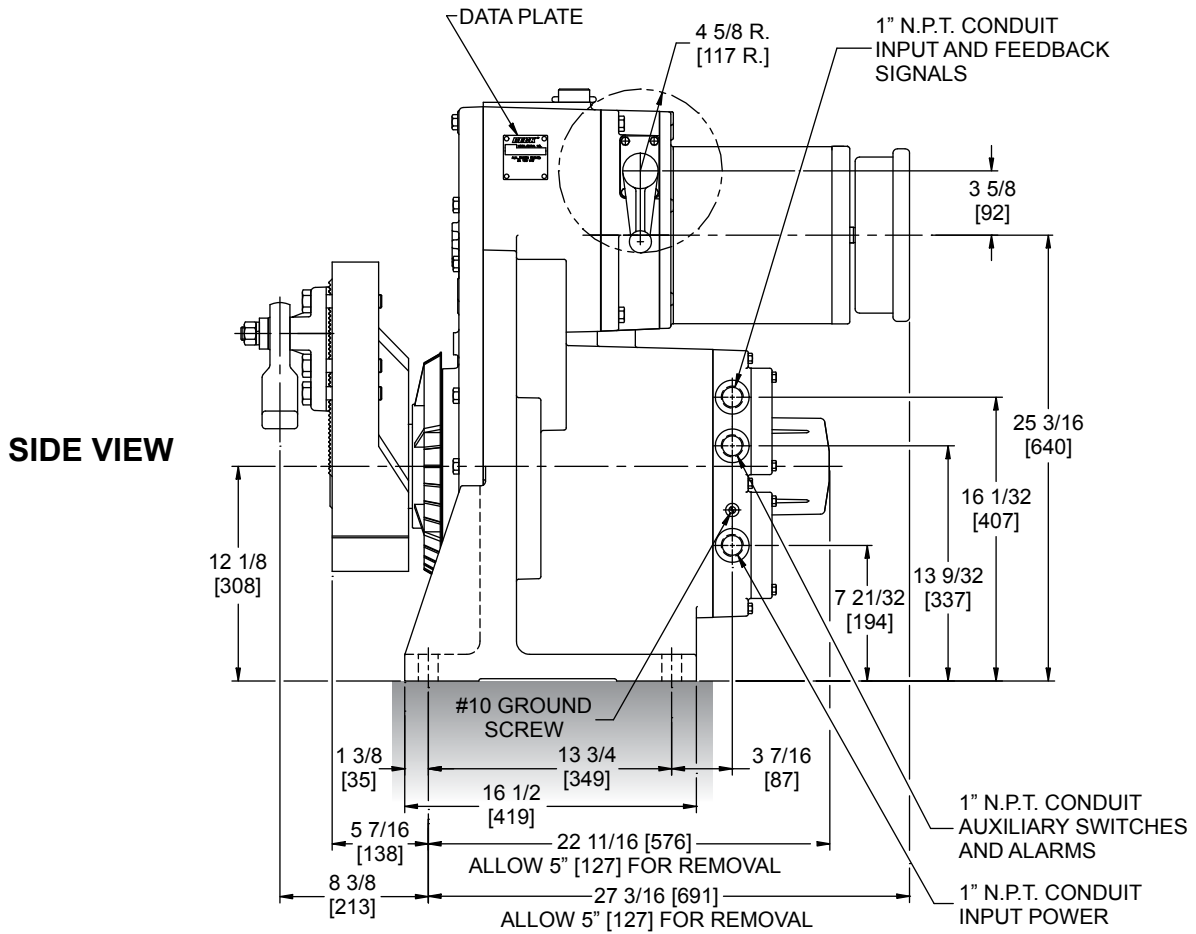

Beck Model No.	Torque (lb-ft)[N•m]	Timing (sec/100°)	Net Wt. (lb)[kg]	Output Shaft Dia. (in)[mm]	Crank Arm Radius (Adjustable) (in)[mm]	Maximum Overhung Load (lb)[kg]
22-809	8,000 [10 847 N•m]	15	1,250 [567]	4 3/4 [121]	10–15 [254–381]	30,000 [13 608]

### CRANK ARM & ROD END

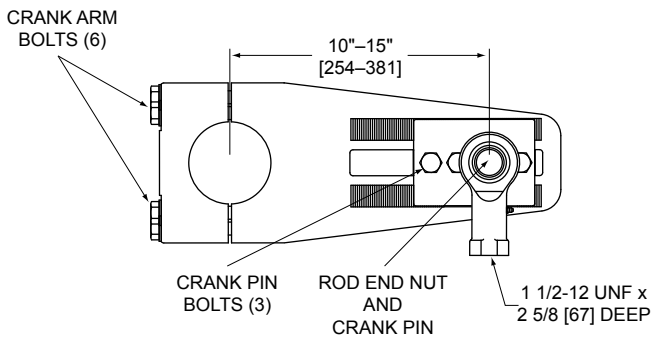

### Fastener Guide

	Size (in.)	Torque (lb-ft)[N•m]
Crank Arm Bolts (6)	3/4-16	420 [569]
Rod End Nut (1)	3/4-16	200 [271]
Crank Pin Bolts (3)	3/4-16	420 [569]
Motor Mounting Nuts (4)	1/2-13	50 [68]
Cover Bolts	5/16-18	10 [14]
Mounting Bolts (4)	1-8	*

\* Torque appropriately for application.

# INSTALLATION

## SAFETY PRECAUTIONS

### WARNING



**Installation and service instructions are for use by qualified personnel only. To avoid injury and electric shock, do not perform any servicing other than that contained in this manual.**

### CAUTION



**Hot surfaces! Surfaces of equipment may be at an elevated temperature depending on operating conditions and environment. Allow to cool before servicing.**

## STORAGE INFORMATION

Beck drives should be stored in their shipping cartons in a clean, dry area.

If it is necessary to store drives outdoors for a long period of time, they should be stored above ground and covered with a waterproof cover. Do not stack cartons on top of one another. Stored drives should be checked periodically to make sure no condensation has formed in the electronic and terminal compartments. Damage due to moisture while in storage is not covered by warranty.

## UNPACKING

Group 22 drives are shipped in slatted wooden crates. Each crate is braced internally at the top and sides of the drive. To unpack, remove the top of the crate first. Next, remove the sides of the slatted crate, carefully removing the support braces. After unpacking, the skid may be used to transport the drive to the installation site.

## INSTALLATION—ELECTRICAL

**NOTE: All Beck drives are shipped from the factory ready for installation; no electrical adjustments are required before placing them in operation. Each drive is set up and calibrated to the customer's specifications that were written into the equipment order.**

Three 1" N.P.T. conduit connections are provided for power and signal wiring to the drive. One conduit is provided for signal wiring connections, and the other conduits are provided for power and auxiliary

switch connections. A sealant must be used on threaded conduit connections to keep moisture out. Conduits should be routed from below the drive so that condensation and other contaminants entering the conduit cannot enter the drive.

Power and signal wires must be routed to the drive separately and be either shielded cables or installed in conductive conduit and/or cable trays.

Shielded, twisted pair cables should be used for signal connections to avoid being affected by electrical noise. These signal wires, based on Noise Susceptibility Level (NSL) per IEEE-518, fall into the level 1 classification. A braided shield will be more effective than a wrapped foil shield. Signal wire shields should be connected to the drive casting grounding screw. If grounding at the signal source is required, then the shield should not be grounded at the drive. Raceways such as conduits and trays have to be grounded at both ends to properly meet immunity requirements.

Large, clearly labeled terminal blocks are enclosed in a separate, gasketed metal enclosure. Terminals will accommodate up to 12 AWG (3.31 mm<sup>2</sup>) wiring.

### CAUTION

**Always close covers immediately after installation or service to prevent moisture or other foreign matter from entering the drive.**

Refer to the wiring diagram furnished with your Beck drive for proper AC power and signal connections. It is advisable to provide normal short circuit protection on the AC power line. A copy of the wiring diagram is shipped with each drive and is fastened to the inside of the terminal block cover. If there is no wiring diagram available, you may obtain a copy from Beck by providing the serial number of your drive.

Your Beck drive has been supplied to match the signal source in your control loop. If it does not match, a 250 ohm input resistor may be added or removed to obtain the proper match. Consult the factory for details.

For maximum safety, and to comply with national and international standards, the Beck drive body is required to be grounded. Separate ground terminals are provided in the wiring compartment for power and signal wiring. Wire size 12 AWG (3.31 mm<sup>2</sup>) is recommended for this purpose.

It should be noted that with industrial equipment, installation restrictions may be applied by supply authorities in relation to harmonics and voltage fluctuations (flicker).

---

## **MOUNTING INSTRUCTIONS**

Beck Group 22 control drives must be installed feet down. Refer to the outline dimension drawings for physical dimensions and required clearances.

The drive must be bolted firmly to a mounting surface which will not yield to the stresses created from operating the device. A rigid, vibration-free surface will prolong the life of the drive. Before the drive is bolted into place, the mounting surface must be shimmed for flatness to within 0.020 inches (0.508 mm). Shims must support a four inch [102 mm] square surface area of each shimmed mounting foot.

The output shaft of the drive should be parallel to the driven shaft and the linkage should be in a plane perpendicular to the two shafts. Small misalignments can be tolerated if a rod end fitting is used on the driven lever similar to that provided on the crank arm.

## **CRANK ARM**

### **Models 22-309 and 22-409**

The Beck 22-309/-409 control drive crank arm can be positioned at any angle on the output shaft. The crank arm is locked to the shaft by four crank arm bolts (see illustration on page 9). The crank arm linkage radius is adjustable from 9 to 15 inches (229 to 381 mm) by use of the crank pin (see illustration on page 9). For detailed information on the crank arm and linkage arrangements, see pages 14–15. For bolt torque values, see the "Fastener Guide" on page 9.

### **Model 22-809**

The Beck 22-809 control drive crank arm can be positioned at any angle on the output shaft. The crank arm is locked to the shaft by six crank arm bolts (see illustration on page 11). The crank arm linkage radius is adjustable from 10 to 15 inches (254 to 381 mm) by use of the crank pin (see illustration on page 11). For detailed information on the crank arm and linkage arrangements, see pages 14–15. For bolt torque values, see the "Fastener Guide" on page 11.

# INSTALLATION LINKAGE

## LINKAGE REQUIREMENTS

For best results, the linkage should be designed in advance. In most applications, the best control will result when the linkage is adjusted so that the full 100° travel of the Beck drive shaft is used, even though the driven lever may travel less than 100°.

The general requirements for a good linkage are:

1. It must be rigid enough to carry the link thrust without bending or deforming.
2. It must have a built-in means of adjustment so that the length of the connecting link can be changed a small amount.
3. Rod end bearings, similar to those furnished on the Beck crank arm, should be used at both ends of the connecting link. This type of device permits small angular misalignments and helps prevent binding of the linkage.
4. The Beck crank arm radius must be calculated so that the arm will move through a 100° arc and the driven lever will move through its correct arc.
5. The drive and driven shafts must be parallel and the linkage should be in a plane perpendicular to the shafts.

## Link-Assist™

The Beck Link-Assist™ computer program optimizes the linkage configuration for your application. Consult your Beck Sales Engineer for information on using the Link-Assist™ program.

## Linkage Kits Available

Standard Beck linkage kits are made to accommodate a wide variation in linkage lengths without requiring modification of end fittings. This adaptability makes it possible to order, with

the drive, the essential linkage end connections even though the exact linkage length may not be known until the drive is mounted in place.

Each linkage kit includes the essential pipe linkage end connections, rod end and all necessary hardware. Schedule 40 pipe is not included and must be cut to length and threaded in the field (see Table 1, this page, for instructions to calculate pipe length). To simplify installation of the pipe link, the kit accepts NPT right-hand threads on both ends of the pipe. Left-hand threads are internal to the linkage kit assembly, making final length adjustments quick and easy.

To order pipe linkage kits, first obtain the approximate overall linkage length "A" in the illustration below. Select the kit part number from Table 1, below. For lengths beyond those listed in the table, contact your Beck Sales Engineer.

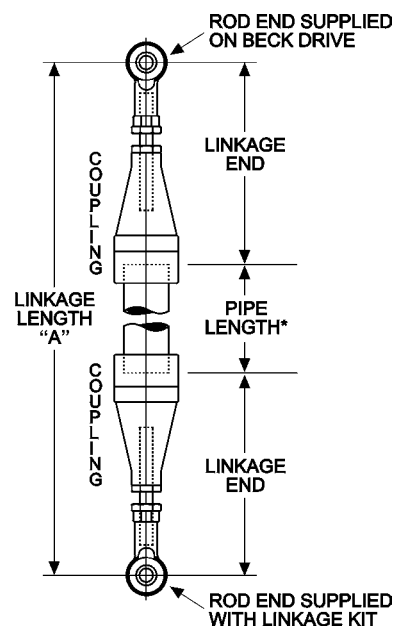

\*NOTE: To calculate length of pipe required, subtract Length of 2 Linkage Ends (shown in Table 1) from Linkage Length ("A").

**TABLE 1:  
PIPE LINKAGE KITS**

Linkage Length Range "A"	Pipe Size	Min. Pipe Nipple Length	Rod End Thread (UNF)	Beck Pipe Linkage Kit Part No.	Length of 2 Linkage Ends (Total Adj. ±1 1/2"(38 mm))	Approx. Weight <sup>1</sup>
23 1/2–40" (597–1 016 mm)	2" (51 mm)	2" (51 mm)		20-1760-13	21 1/2" (546 mm)	28 lbs (13 kg)
37 3/4–144" (959–3 658 mm)	3" (76 mm)	2 5/8" (67 mm)	1 1/2-12	20-1760-10	35 1/8" (892 mm)	32 lbs (15 kg)
59 3/4–144" (1 518–3 658 mm)	3" (76 mm)	2 5/8" (67 mm)		20-1760-09 <sup>2</sup>	57 1/8" (1 451 mm)	41 lbs (19 kg)

<sup>1</sup> Does not include customer supplied pipe.

<sup>2</sup> Use when the angle between the linkage and crank arm is less than 25°.

## Linkage Installation

The following procedure is recommended to couple the linkage between the Beck Group 22 drive and the driven shaft:

1. Position the driven shaft to the full reverse (damper closed) position.
2. Set the driven shaft lever to its predetermined starting angle in relation to the driven shaft and drive shaft centerline.
3. Remove the rod end from the Beck crank arm. Attach to the connecting link.
4. Adjust the connecting link to the predetermined length.
5. Connect the connecting link to the driven lever at the predetermined radius.
6. Set the crank pin (see appropriate illustration on page 9 or 11) on the Beck crank arm to the predetermined radius (between 9 and 15 inches (229 mm and 381 mm) for the 22-309/-409, and between 10 and 15 inches (254 mm and 381 mm) for the 22-809). This is done by loosening the crank pin bolts and sliding the crank pin to the predetermined position. Tighten the crank pin bolts to the appropriate torque recommended on page 9 or 11.
7. Loosen the crank arm bolts. **CAUTION:** The crank arm will pop free—approximate weight is 130 lbs (59 kg) (22-309/-409) or 144 lbs (65 kg) (22-809).
8. Position the drive's output shaft to its full reverse limit.
9. Swing the crank arm into position and assemble the connecting link to the crank arm crank pin. Tighten the rod end bolt to the appropriate torque recommended on page 9 or 11.
10. Tighten the crank arm bolts evenly, in a cross-pattern, to the appropriate torque recommended on page 9 or 11.
11. Lubricate the rod end bearings.

Carefully move the drive's output shaft to the full forward (maximum input signal) position. Check that no binding occurs between the linkage, crank arm, driven shaft lever, and surrounding obstructions. Also observe that the driven shaft rotates the proper amount. Check that the drive reaches the forward limit and shuts off.

If binding in the linkage occurs due to too much travel of the driven lever, attempt to correct the problem by reducing the crank arm radius.

If reducing the crank arm radius does not solve the problem, adjust the linkage length by altering the thread engagement in the couplings. Only if necessary, the rod ends may also be adjusted.

### CAUTION

**The thread engagement depth in the couplings and rod ends must be greater than the thread diameter.**

The couplings have right- and left-hand threads, so it is not necessary to disconnect the ends to make a length adjustment.

For a Demand input control signal change, do not adjust the linkage. The Demand input signal calibration of the DCM board is easily changed to adjust the amount of rotation when a change in maximum input signal or span is required.

Once again, check operation to determine that no binding occurs between the linkage and crank arm, driven lever arm, or surrounding obstructions.

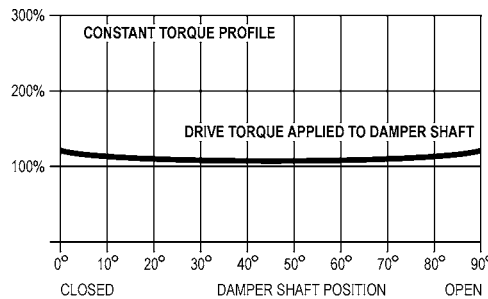

#### BECK CONTROL DRIVE DATA

Model Number: 22-309  
Rated Torque: 3000 lb-ft

#### LINKAGE DATA

Horizontal Offset: 00.00 inches  
Vertical Offset: 72.00 inches  
Connecting Link Length "A": 72.01 inches

#### BECK CRANK ARM DATA

Required Rotation: 100 degrees  
Start Position: 310 degrees  
Radius "C": 11.08 inches

#### LOAD LEVER ARM DATA

Required Rotation: 90 degrees  
Start Position: 315 degrees  
Radius "L": 12.00 inches

DRIVE CRANK ARM ROTATION degrees	LOAD LEVER ARM ROTATION degrees	LOAD LEVER TORQUE lb-ft	LOAD LEVER/ CRANK ARM TORQUE RATIO	LINK FORCE lbs
0.0	0.0	3563	1.19	4945
10.0	8.6	3410	1.14	4186
20.0	17.5	3327	1.11	3722
30.0	26.6	3281	1.09	3442
40.0	35.8	3257	1.09	3293
50.0	45.0	3250	1.08	3250
60.0	54.3	3258	1.09	3308
70.0	63.4	3283	1.09	3476
80.0	72.5	3331	1.11	3785
90.0	81.4	3420	1.14	4302
100.0	90.0	3589	1.20	5174

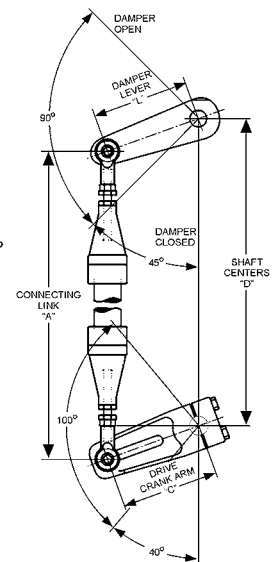

#### System Operating Conditions

Drive Torque = 3,000 lb ft  
Center Distance "D" = 72 in.  
Damper Rotation = 90°  
Damper Start Position = 315°  
Drive Rotation = 100°  
Drive Start Position = 310°  
Damper Lever "L" = 12 in.

### LINK-ASSIST™ AND LINKAGE ARRANGEMENT EXAMPLE (LINK-ASSIST™ AVAILABLE IN METRIC)

# INSTALLATION WIRING

Three conduit entrances (1" NPT) are provided for supplying power and signal wiring to the control drive. All input power terminal screws (terminals 1–3) should be tightened to 10 lb-in (20 lb-in on model 22-809 and optional transformer). All signal wiring terminal screws (terminals 4–21) should be tightened to 9 lb-in. Both the power and signal ground screws should be tightened to 20 lb-in.

## TERMINAL CONNECTIONS

**Capacity: #12 AWG (3.31 mm<sup>2</sup>) wire**

### Input Power

#### Terminals 1, 2, and 3

Standard input power for the 22-309 is 120 Vac, single-phase (refer to drive nameplate for specific voltage rating). Input power connects to terminals 1 and 2; ground connects to an enclosure ground screw. Terminal 3 is unused for 120 Vac operation. 208, 240, 380, 416, 480 & 575 Vac three-phase operation is available with an optional transformer (see figure on page 17).

Standard input power for the 22-409 is 208 Vac, three-phase (240, 380, 416, 480 & 575 Vac is available with an optional transformer (see figure on page 17)). Input power for the 22-809 is 208, 240, 380, 416, 480 or 575 Vac, three-phase (refer to drive nameplate for specific voltage rating). Input power connects to terminals 1, 2 and 3; ground connects to an enclosure ground screw.

Group 22 drives are equipped with a surge suppressor assembly installed across each, or a combination of, terminals 1, 2 and 3 (dependent upon your drive model and configuration). Note: The surge suppressor assembly should not be removed.

### Auxiliary Switches

#### Terminals 4 through 9

Group 22 drives include two “auxiliary” switches which are actuated by cams on the control shaft. These switches are useful for indicating drive shaft position information to the plant control system. Connections to the switches are at terminals 4 through 9. The switch contacts are rated 250 Vac, 1 A.

### Handswitch Auto Indication

#### Terminals 10 and 11

Indication for the position of the Handswitch is available at terminals 10 and 11. The switch contacts are Form A, and are shown in the figure below. When the Handswitch is in AUTO, the

contacts are closed; and when the Handswitch is not in AUTO, the contacts are open. The contacts are rated 250 Vac, 1 A.

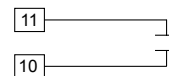

### System Alarm

#### Terminals 12 and 13

Indication of the System Alarm is available at terminals 12 and 13. The contacts are Form A and are shown in the figure below. During alarm conditions, the contacts are open; during normal operation, the contacts are closed. The contacts are rated 120 Vac/Vdc, 80 mA max.

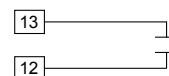

### Demand Signal

#### Terminals 14 and 15

The DCM monitors the signal at terminals 14 (–) and 15 (+), and changes the output shaft position to match the signal at these terminals.

### Feedback Signal

#### Terminals 16 and 17

The Feedback module, when enabled, transmits a signal on terminals 16 (–) and 17 (+) that is proportional to the drive output shaft position.

### Control Override Inputs

#### Terminals 18 through 21

The override terminals are provided for relay logic input signals to override the standard analog demand input signal.

#### CAUTION

**Do not connect an external voltage source to override terminals 18–21; an external voltage source may damage the DCM circuitry.**

Connecting terminal 19 (CW) to terminal 18 (COM) will cause the drive to run in the CW direction. Similarly, the drive will run in the CCW direction when terminal 20 (CCW) is connected to terminal 18 (COM). The drive will stop regardless of other input signals when terminal 21 (STOP) is connected to terminal 18 (COM).

The connection to terminal 18 is designed to be made through relay contacts or through a solid state switch capable of sinking at least 5 mA dc. When the circuit is open, terminals 19, 20, and 21 are +12 V dc with respect to terminal 18.



**MODEL 22-309/-409  
TERMINAL  
CONNECTIONS**

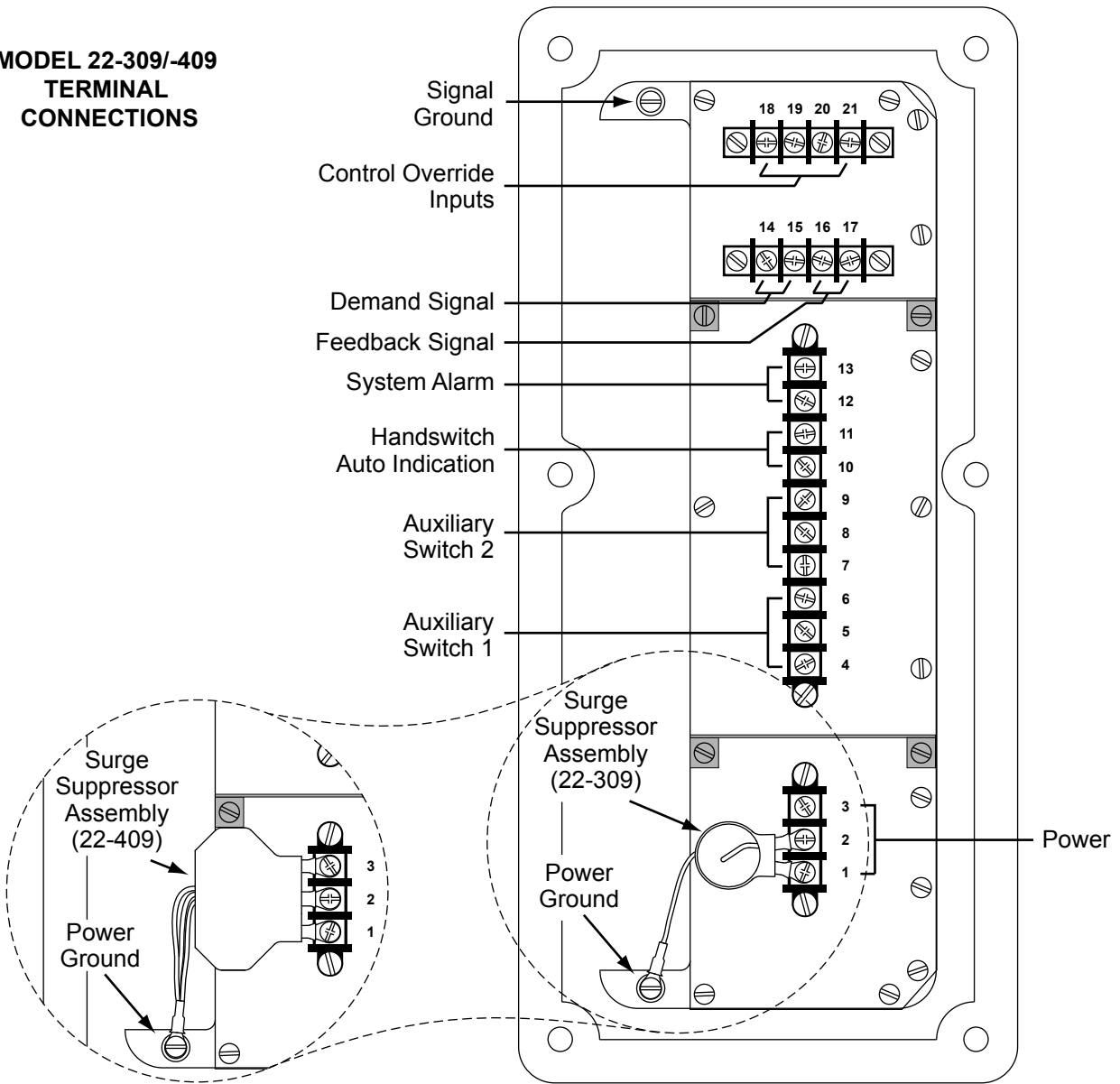

**MODEL 22-309/-409  
POWER  
CONNECTIONS  
WITH OPTIONAL  
TRANSFORMER  
ENCLOSURE**

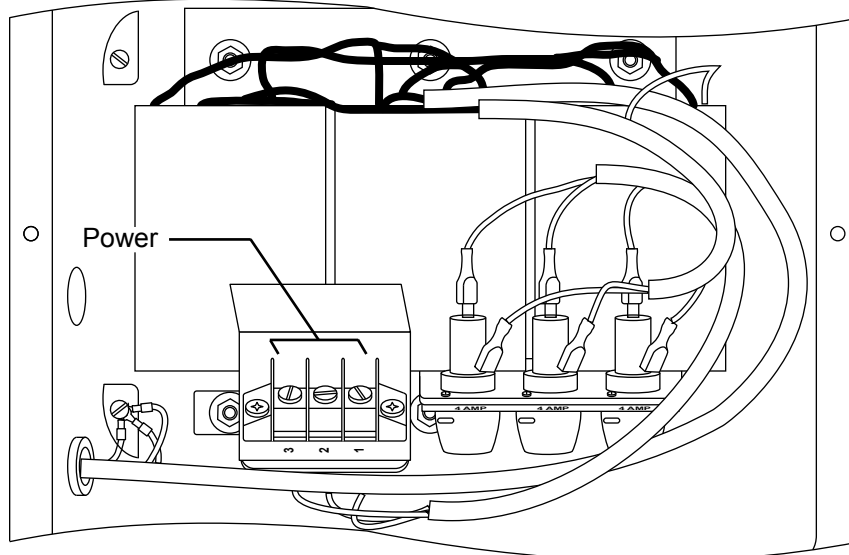

# INSTALLATION WIRING

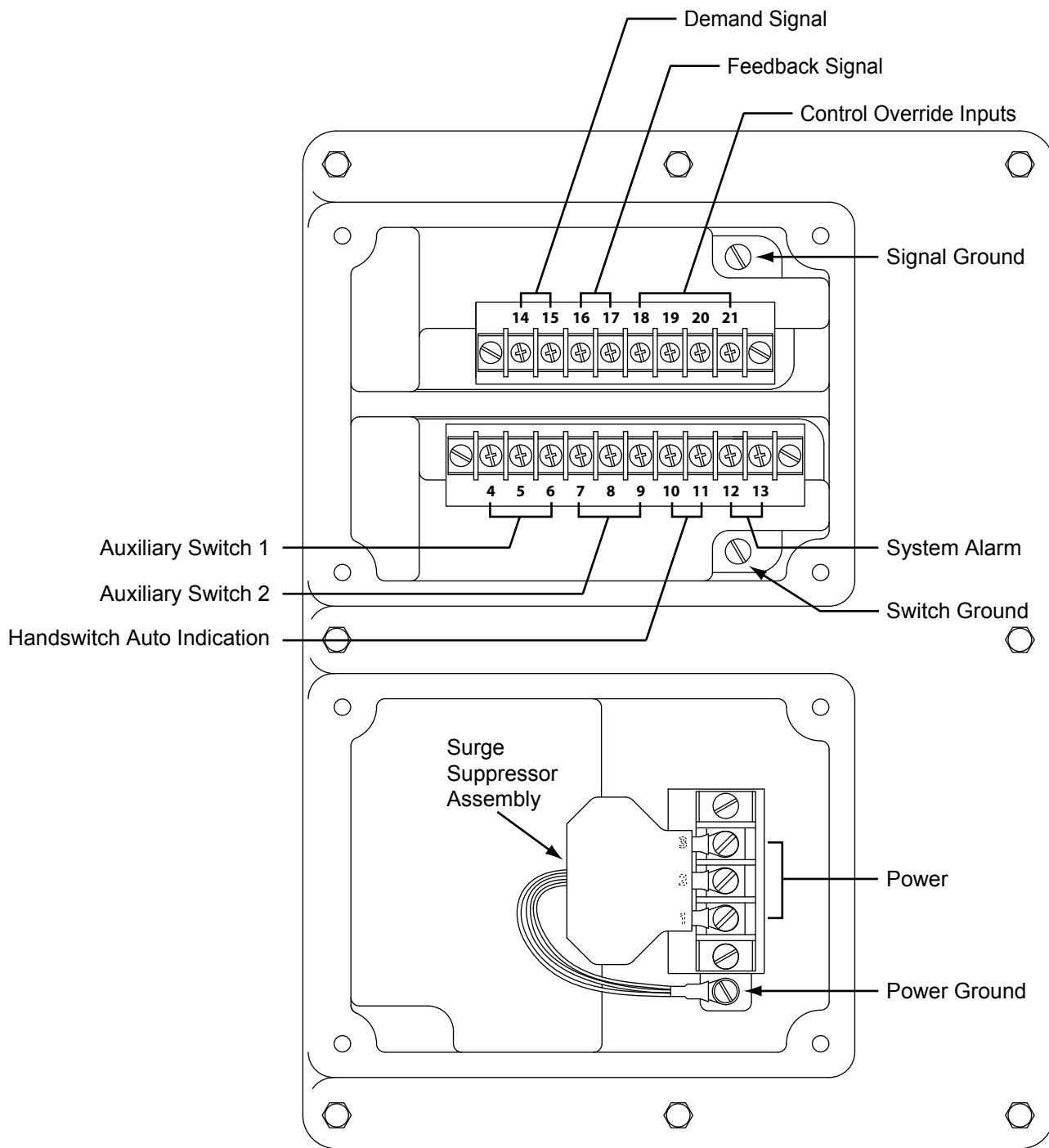

**MODEL 22-809 TERMINAL CONNECTIONS**

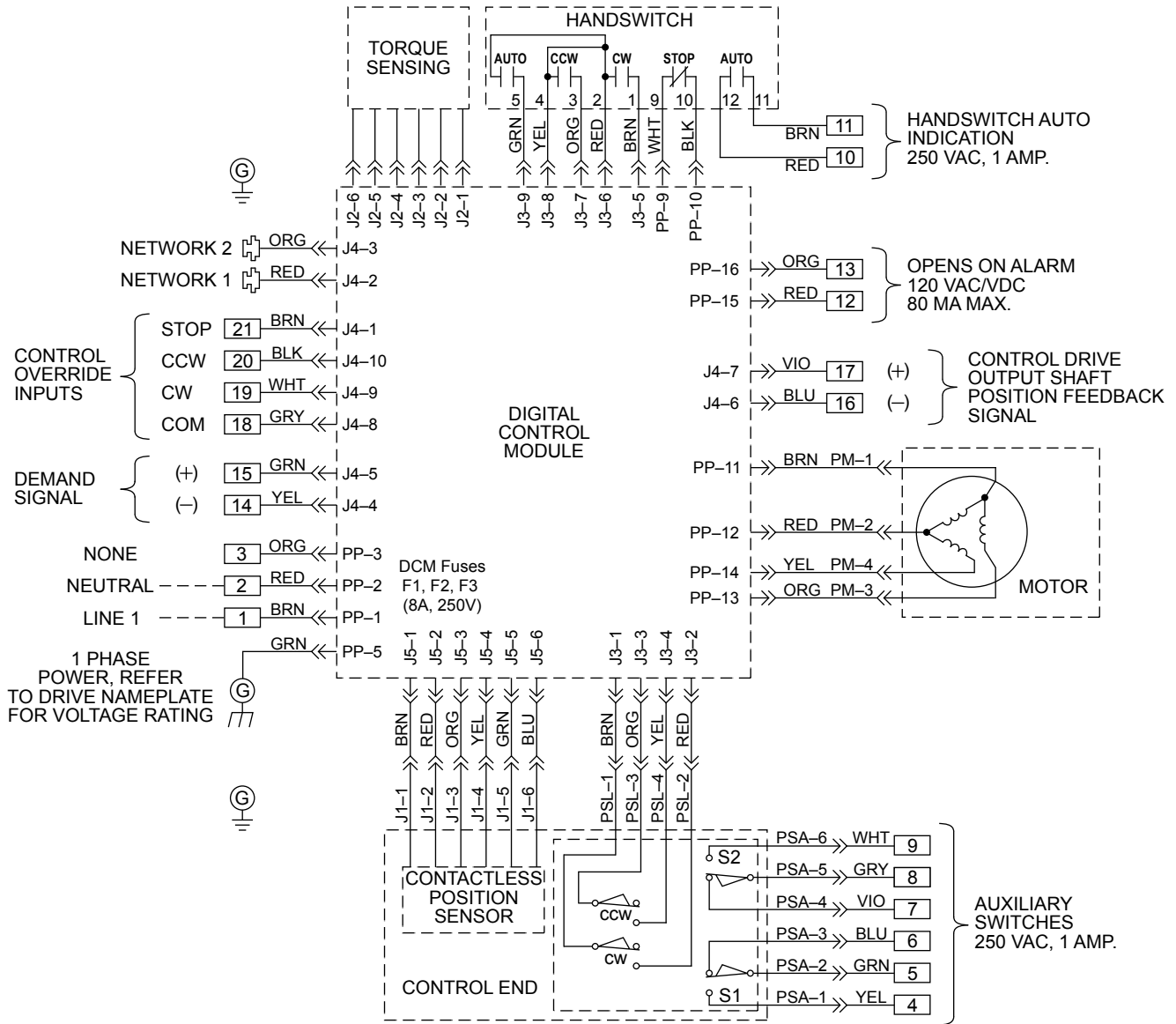

— # CUSTOMER TERMINAL BLOCK

INPUT/FEEDBACK SIGNALS:  
ISA TYPE 4, CLASS U, POWER ISOLATED

**MODEL 22-309 TYPICAL WIRING SCHEMATIC**  
(a wiring schematic specific to each drive is located under the wiring terminal cover)

# INSTALLATION WIRING

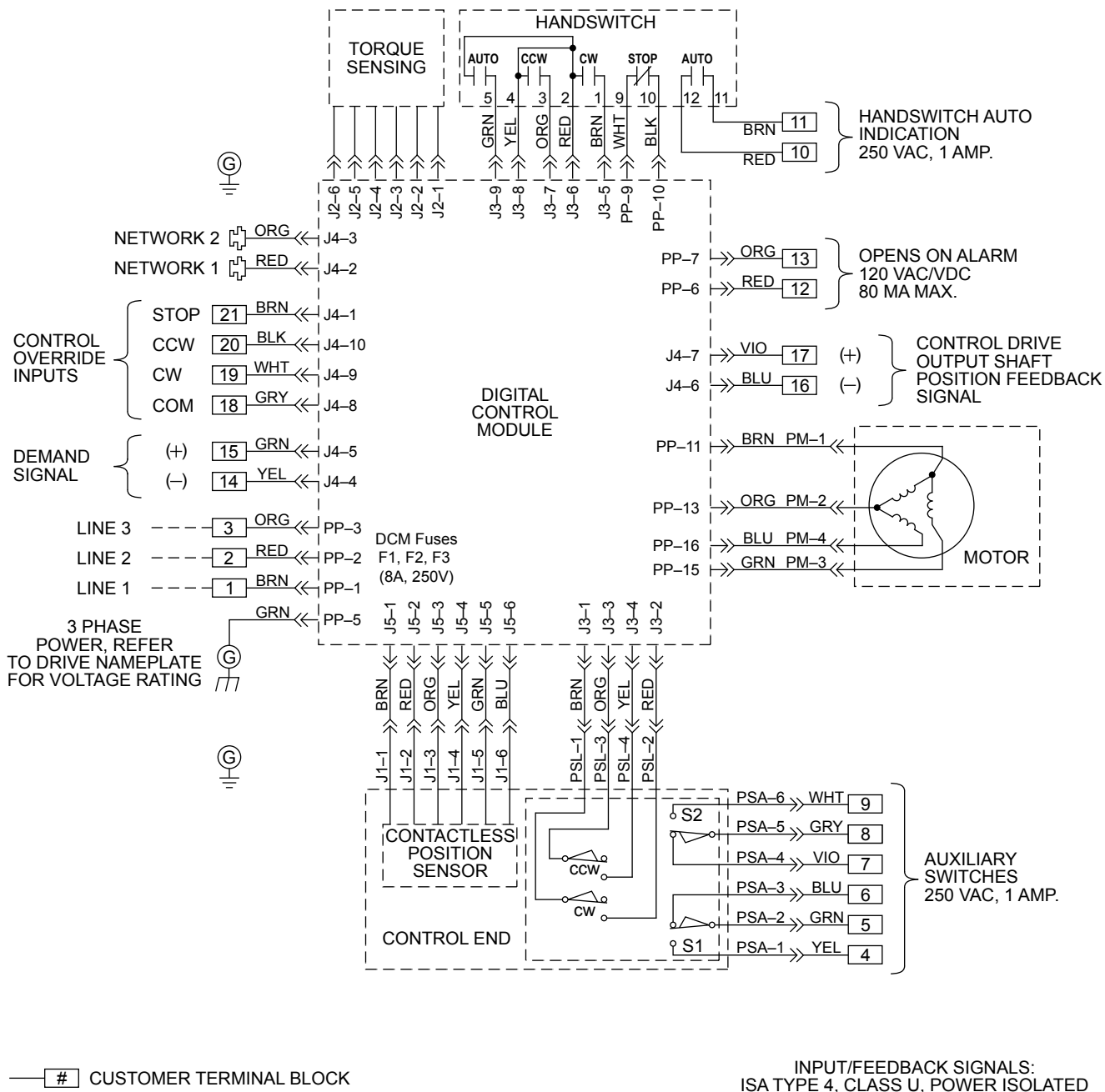

**MODEL 22-409 TYPICAL WIRING SCHEMATIC**  
(a wiring schematic specific to each drive is located under the wiring terminal cover)

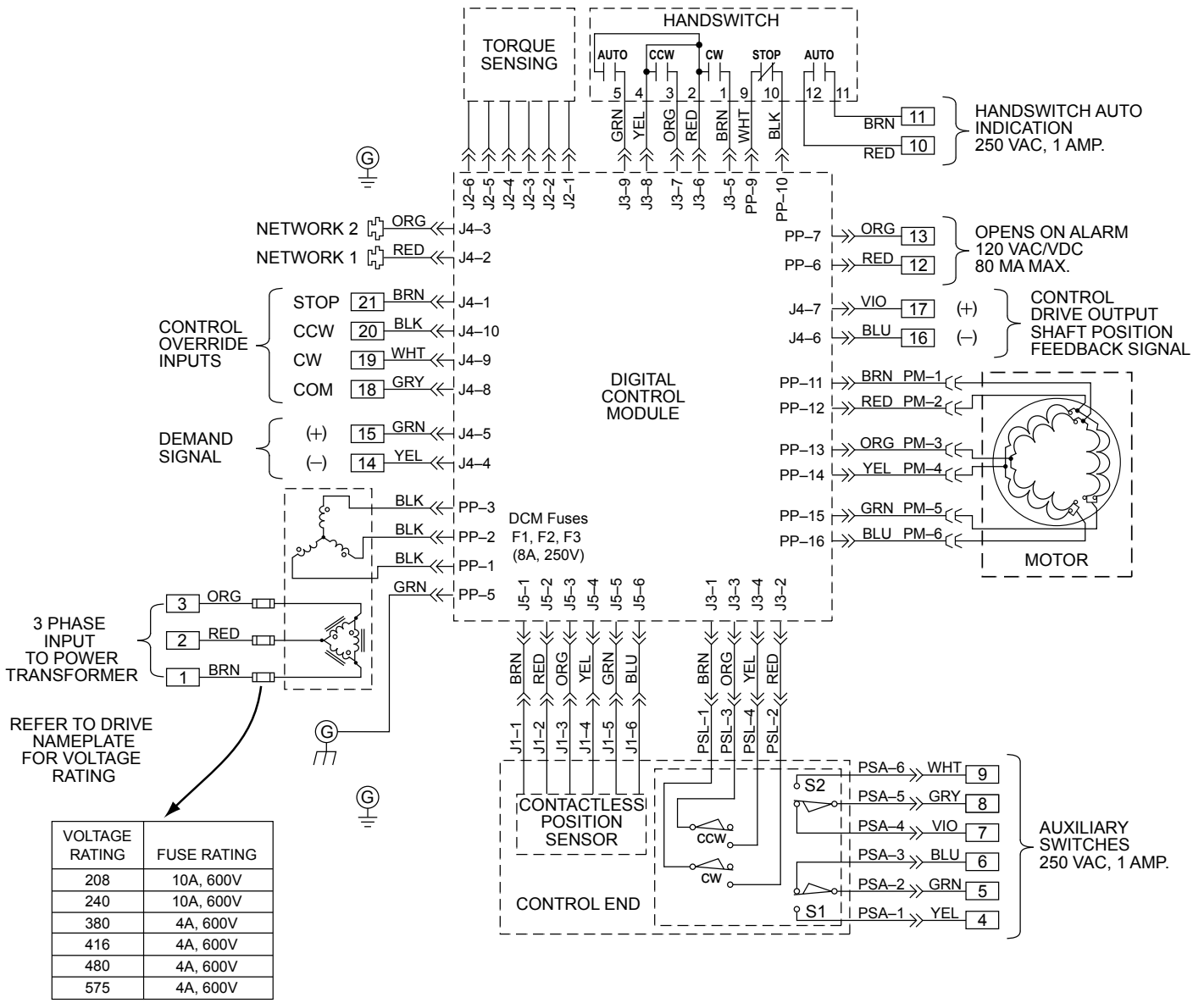

— # CUSTOMER TERMINAL BLOCK

INPUT/FEEDBACK SIGNALS:  
ISA TYPE 4, CLASS U, POWER ISOLATED

**MODEL 22-809 TYPICAL WIRING SCHEMATIC**  
(a wiring schematic specific to each drive is located under the wiring terminal cover)

# INSTALLATION *START-UP*

---

## BEFORE START-UP

**NOTE: All Beck drives are shipped from the factory ready for installation; no electrical adjustments are required before placing them in operation. Each drive is set up and calibrated to the customer's specifications that were written into the equipment order. If your requirements have changed since the time of order, the following sections will provide the instruction necessary to reconfigure your drive.**

Confirm that the proper input power voltage is available. Check the drive configuration to make certain the drive matches the power and control system specifications (refer to the drive nameplate). Check the output shaft and crank arm assembly for proper attachment. Make certain the linkage is properly connected. Inspect the drive mounting platform and hold-down bolts.

For increased personal safety, on the first start-up, place the Handswitch in a STOP position. Make certain no movement of the crank arm or linkage can cause personal injury.

## AFTER POWER IS APPLIED

Using the Handswitch (see Outline Dimension Drawings, pages 8–11), run the drive CW and CCW. The drive should run smoothly to each end of travel. If the drive does not run smoothly, switch off power to the drive and recheck the installation wiring. Check the linkage for proper configuration and adjust if binding occurs.

If the above checks are satisfactory, move the Handswitch to AUTO and control the drive with the Demand signal.

### CAUTION

**The drive output shaft will reposition.**

Vary the signal and ensure the drive responds appropriately. If applicable, check the feedback signal to see if it is realistic for the drive output shaft position. If the drive does not respond as expected, check for alarm indications on the LEDs of the DCM-L board or, if equipped with a DCM-H, use the HART compatible communicator to check for error messages. Drive status may also be viewed through use of the RS-232 connector (see page 54 for details).

# CONFIGURATION & SETUP

---

All Beck drives are shipped completely calibrated to customer specifications, and are ready to be installed. If the need arises to change the drive calibration, confirm that the drive is installed as specified and operating properly before proceeding with the change. It is also helpful to verify the drive configuration.

With the exception of the settings for the over-travel protection switches, auxiliary switches and CPS, all calibration is performed using the DCM-H HART interface or the DCM-L pushbutton local interface board. If your drive is equipped with a DCM-H and you are unfamiliar with the HART communicator, please review the Communications section of this manual before continuing. Both the DCM-H and DCM-L are equipped with an RS-232 connector to allow direct communication with a computer through a serial interface (see page 54 for details).

There are four standard DCM-H attributes that can be calibrated using the HART interface and communications tool: Position, Demand, Feedback, and Torque. The DCM-L allows Position and Demand calibration.

If equipped with a DCM-H, any drive calibration changes that are made using the HART interface can be reversed by using the “Restore to Factory” feature in the HART communicator menu. This feature restores all calibration and setup information at once.

## CONFIGURATION PRIORITY

Group 22 drives are equipped with built in, non-adjustable mechanical stops. All output shaft rotation must occur within these stops, which are outside the electrical range of travel.

The over-travel protection switches are used to limit the electrical control range of the drive. These switches are cam operated, and are set slightly wider apart than the drive’s intended full range of normal electronic operation. For the typical operating range of 100 degrees, the over-travel protection switches are set approximately 101 degrees apart. The switch cams are positioned to provide an electrical over-travel protection without opening in the normal operating range.

If there is a need to change the factory calibration and configuration of the drive, it should be done in a priority sequence as follows:

1. If required, make all mechanical adjustments to the limit switches first.
2. Make any required operating changes such as changing the direction of rotation, action upon loss of signal, minimum drive step size, etc.
3. If required, perform a drive position calibration.
4. If required, perform a drive demand calibration.
5. Verify that the drive works correctly as desired.

For example, if the drive is short-stroked (i.e., the full travel rotation from 0–100% is reduced to less than the standard 100 degree rotation—see the Short-stroking instructions in the appropriate DCM-H or DCM-L section that follows), the over-travel protection switches should be reset. Because the over-travel protection switches define the drive’s maximum range, if they are to be reset, they should be adjusted before performing DCM calibration procedures. Calibration procedures for these switches are the same regardless of the DCM type installed in the drive.

The auxiliary switches are also cam operated, but have no affect on DCM operation. Therefore, they can be adjusted at any time without affecting performance or calibration.

# CONFIGURATION & SETUP SWITCHES

## SWITCH CALIBRATION

**NOTE: Your Beck drive was shipped from the factory ready for installation; no electrical adjustments are required before placing it in operation. Each drive is set up and calibrated to the customer's specifications that were written into the equipment order.**

Under normal operating conditions there is no need to recalibrate the control drive. However, if the application requirements change or are different than specified on the equipment order, the drive should be recalibrated according to the following procedures.

## Switch Adjustments

All control drives are shipped with over-travel protection switches factory-set for 101° of travel unless otherwise specified at time of order. The switches are set to provide electrical over-travel protection. The switches must be set inside the range of the built-in mechanical stops. The switches can be reset to limit travel of the output shaft to any angle down to a minimum of approximately 60°. Auxiliary switches are factory set, as shown in the illustration below, unless otherwise specified at time of order.

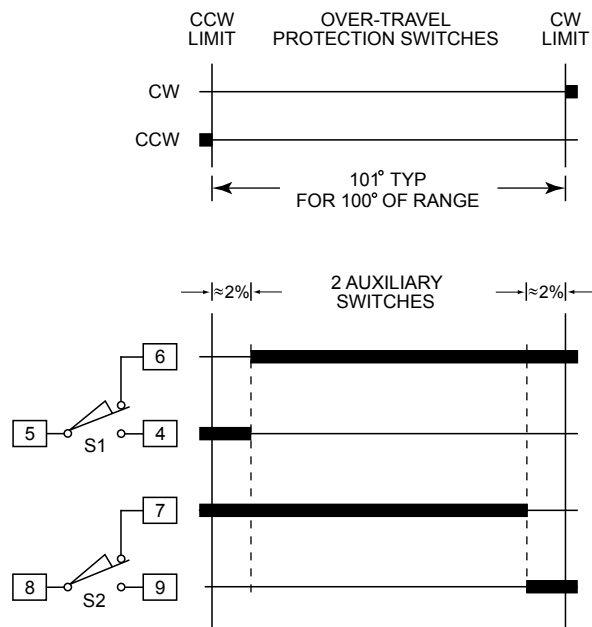

Note: The switch contacts are shown at midpoint of travel.

CONTACTS CLOSED  
 CONTACTS OPEN

### Standard Over-travel Protection and Auxiliary Switch Settings

Switches are operated by cams which are clamped onto the control shaft. Setting a switch involves loosening the thumb nut, moving the drive's output shaft to the desired position, and positioning the cam so that it operates the switch at that point. In the following procedure, the use of a continuity meter is recommended to determine when the switch opens or closes. If such a meter is not available, it is possible to hear the switch click as the contacts open and close.

### CAUTION

**Do not attach the meter or attempt to move the switch cams until the drive is disconnected from the line voltage and auxiliary switches are disconnected from external power sources.**

## Setting Over-travel Protection Switches CW and CCW

This procedure should be used if the factory over-travel switch settings must be changed in the field. It is advisable to operate the drive fully in each direction—using the Handswitch and Handwheel—to check switch settings before attempting to change them. Use the following instructions if they require adjustment:

1. Remove the control end cover and terminal block cover (1/2" bolt heads).
2. Use the Handswitch to drive the control shaft so that the thumb nut locking screw is accessible. While holding the shaft coupling, use a 3/32" hex wrench and loosen the screw on the thumb nut. Loosen the thumb nut by turning it counter-clockwise approximately 1/4 turn. See the illustration on the following page.
3. Move the output shaft clockwise to the CW end of travel limit.
4. Turn the Handswitch to the STOP position.
5. Use the Handwheel to position the output shaft at the desired over-travel limit.
6. Disconnect power from the drive.
7. Connect the continuity meter across the appropriate pins of the J3 connector on the DCM board (Pins 1 & 2 for the CW switch, pins 3 & 4 for the CCW switch). See the illustration of the control board on page 33 and the drive wiring diagram (or the appropriate diagram on pages 19–21).
8. While holding the shaft coupling stationary, rotate the appropriate cam using the 3/32" hex wrench in one of the cam adjustment slots (see drawing on page 25 for location of slots) until the meter shows continuity (switch contacts closed, switch clicks).



9. Turn the thumb nut clockwise until hand tight. Tighten the thumb nut locking screw to 5 lb-in (0.6 N•m) torque.
10. Use the Handwheel and confirm that the contacts are open in the normal operating range and close at the desired over-travel limit.
11. Disconnect the meter and reconnect drive power.
12. Repeat instructions for setting (and verifying) CCW over-travel protection switch (noting that referenced directions of rotation should be opposite of those used for CW switch setting).
13. Replace covers and tighten cover bolts to 10 lb-ft torque.
14. If necessary, rotate the index to properly correspond to the output shaft rotation.

1. Remove the control end cover and the terminal block cover (1/2" bolt heads).
2. Use the Handswitch to drive the control shaft so that the thumb nut locking screw is accessible. While holding the shaft coupling, use a 3/32" hex wrench and loosen the screw on the thumb nut. Loosen the thumb nut by turning it counter-clockwise approximately 1/4 turn. See illustration below.
3. Move the output shaft to the desired position.
4. Turn the Handswitch to the STOP position.
5. Disconnect power from the drive and switch terminals.
6. Connect the continuity meter across the appropriate terminals as depicted in the diagram on page 24.
7. While holding the shaft coupling stationary, rotate the appropriate cam using the 3/32" hex wrench in one of the cam adjustment slots (see drawing on this page for location of slots) until the meter shows continuity (switch contacts closed, switch clicks).
8. Turn the thumb nut clockwise until hand tight. Tighten the thumb nut locking screw to 5 lb-in (0.6 N•m) torque.
9. Disconnect the meter and reconnect power.
10. Move the drive's output shaft in the desired direction so that the cam lobe moves away from the switch lever. If not correct, return to step 2 and reset the cam to the proper orientation.
11. Replace covers and tighten cover bolts to 10 lb-ft (14 N•m) torque.

## Setting Auxiliary Switches

Standard switch settings for the 2 auxiliary switches are shown on the diagram on the preceding page. The operating point of auxiliary switches is defined as a percentage of output shaft travel. 100% is defined as the clockwise limit of shaft travel when facing the end of the shaft where the crank arm is located. The heavy line indicates a closed circuit. Use the following instructions to change the operating point of auxiliary switches:

**NOTE: In the following procedure, it is assumed that switch settings are to be adjusted so that contacts are open when the desired position is achieved.**

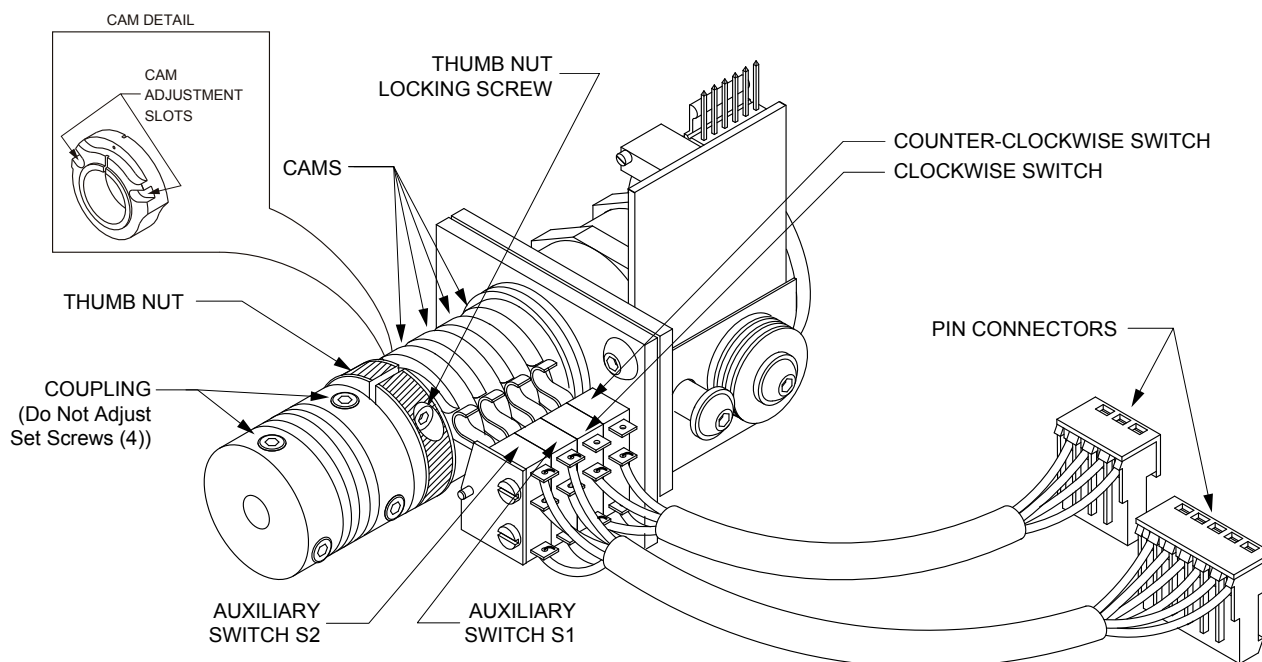

**CONTROL END / CONTACTLESS POSITION SENSOR**

# DCM CONFIGURATION & SETUP

All drives are shipped completely configured to the customer's specifications and are ready to be installed. If the need arises to change the configuration of the drive (i.e., change one or more of the setup parameters that define how the drive operates), this is easily accomplished using one of three methods.

If the drive is equipped with a DCM-H, changing setup parameters is done through the HART interface and a communications tool (model 275 HART Communicator) as described in the Communications section (see page 36) of this manual. The following section of the manual explains how the drive is configured and gives instructions for changing each particular setup parameter available. It is intended to build upon the Communications Section, which provides a detailed description of the HART Menu Tree and defines all the parameters and commands. **If unfamiliar with the HART communicator and Beck drives, please review the Communications section (beginning on page 35) before proceeding.**

Drives equipped with a DCM-L are not compatible with HART protocol; therefore, to facilitate configuration modifications, the DCM-L has an integral interface that allows basic configuration and diagnostic functions to be performed local to the drive. Drive direction of rotation, degrees full rotation and demand signal response can all be easily modified using this interface. Operating parameters less commonly modified can only be changed using the serial communications as described below.

Both DCM types (HART compatible DCM-H and local configuration DCM-L) provide an RS-232 connector for direct communication with a computer using the serial interface (see page 54 for details). The serial interface may be used for drive configuration changes, drive information reporting and to assist in troubleshooting.

For HART compatible DCM-H equipped drives, serial communications are simply an alternative to using the HART configuration. In DCM-L equipped drives, serial communications not only provide an alternate configuration method, but also provide access to parameters that cannot be changed using the local interface.

There are a number of configuration setup parameters that can be changed to tailor the drive's operation to the application needs. The following section (pages 27–44) provides instructions for changing these parameters using the HART interface via a HART Communicator

connected to the drive's HART communication port (see page 4 for location). Reference the copy of the HART Menu Tree (see foldout at the back of this manual) when following these instructions. To change these parameters using the Serial Interface, see pages 54–62.

The DCM default values for both the HART and Serial Interface are listed in the chart below. If not otherwise specified at the time of order, these are the values set in the DCM.

**NOTE: The instructions on pages 27–44 are applicable to drives equipped with the DCM-H only. The instructions on pages 45–51 are applicable to drives equipped with the DCM-L only.**

## CAUTION

**Throughout the following instructions, some configuration changes will cause the drive to reposition after the Handswitch has been placed back in AUTO.**

## DCM HART and SERIAL INTERFACE DEFAULT VALUES

OPERATING PARAMETERS	HART INTERFACE		SERIAL INTERFACE	
	Variable Name	Default Value	Command	Default Value
Drive Rotation (Increasing Signal)	Drive Dir	CW	drvrotation	0 (CW)
Operation Mode	Op Mode	Follow	opmode	0 (follow)
Torque Zero	Trq Null	*	torq0k	*
Torque Constant	Trq Const	*	torqconst	*
CPS Volts at 0°	CPS Zero	1.300	cpsvat0deg	1.300
CPS Volts per 100°	CPS Span	2.400	cpsvper100deg	2.400
Degrees Rotation	Deg Rot	100.00	degsrot	100.00
Demand LOS Threshold (mA)	DemLimLwr	3.20	demlos	3.20
Demand LOS Mode	LOS Mode	Stay	demlos	sip
Demand LOS Go To Position (%)	LOS Pos	50.00	demlosgtp	50.00
0% Demand (mA)	DemRngLwr	4.00	dem0pctma	4.00
100% Demand (mA)	DemRngUpr	20.00	dem100pctma	20.00
Stall Time (Sec)	Stall Time	300	stalltime	300
Demand Function	Dem Curve	Linear	demfunc	linear
Step Size	Step Size	0.10	stepsize	0.10
IO Mode	Feedback	Enabled	iomode	1 (fdbk)
0% Feedback (mA)	FB RngLwr	4.00	fdbk0pctma	4.00
100% Feedback (mA)	FB RngUpr	20.00	fdbk100pctma	20.00
Torque Enable	Trq Snr	Enabled	torqenable	1 (enabled)
Over Torque Stop	Ovt Prot	Disabled	ovtstop	0 (go)
Polling Address	Poll Addr	0	polladdr	0
Drive Timing	--	--	drvtiming	**
Limit Alarm	LimitSwitch	Accept	limitalarm	0
Drive Model	Model	22-809***	drvmodel	14 (22-809)***

\* The specific numbers for these values are unique to each drive and are determined during manufacture. These numbers are noted on a tag affixed to the drive body within the Electronics Compartment.

\*\* "15" sec./100° for models 22-409 & 22-809; "30" sec./100° for model 22-309.

\*\*\* Other HART Values are "22-509" (for model 22-409) and "22-309". Other Serial Values are "13" (22-409) and "12" (22-309).

# DCM-H CONFIGURATION & SETUP

## HART COMPATIBLE DRIVES ONLY

**NOTE:** These instructions are applicable to drives equipped with the DCM-H only. The instructions on pages 45–51 are applicable to drives equipped with the DCM-L only.

### DRIVE SHAFT ROTATION

Drive shaft rotation refers to the direction the output shaft of the drive rotates in response to an increasing Demand input signal. The rotation is either clockwise (CW) or counterclockwise (CCW) as shown in the figure on this page. The control loop operation and physical design of the final control element determine the drive rotation suitable for an application. If the drive rotation needs to be changed, this is easily accomplished by changing the DCM configuration.

### Changing Drive Shaft Rotation

To select a Drive Shaft Rotation using the HART Communicator, proceed through the following menus (see the complete menu structure at the back of the manual):

- Online
  - > Functions
  - > Configuration
  - > Drive Setup
  - > Drive Dir

Choose the desired option and press the ENTER key. Remember to press the SEND key to execute the change. Adjust the travel index.

### Reducing Full Rotation (Short-stroke Operation)

Typically, it is best to use the full 100 degrees rotation of the drive in response to the 0–100% Demand input signal. However, in certain applications it may become necessary to reduce this response to less than 100 degrees. In these applications, the DCM can be calibrated to accommodate reduced stroke. Full stroke rotation of 60 degrees or less is not recommended—contact the factory for details concerning your specific application. It is desirable to make the range as close to 100 degrees as possible.

The following is a typical example of how to short-stroke a drive. The figure below shows a Beck drive configured for a CW 80 degree full stroke rotation.

To check or set the 0–100% rotation distance in degrees using the HART Communicator, proceed through the following menus:

- Online
  - > Functions
  - > Configuration
  - > Drive Setup
  - > Deg Rot

Enter the full stroke rotation in degrees (80 for the example shown) and press the ENTER key. Remember to press the SEND key to execute the change.

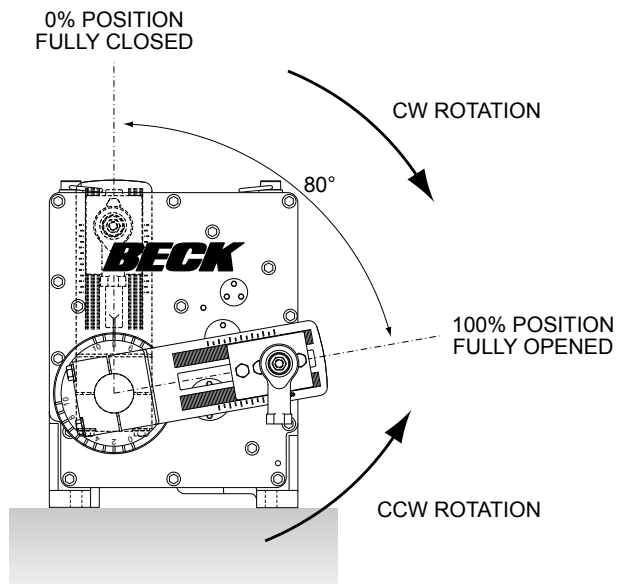

**NOTE:** The crank arm in the above figure may be adjusted to any start angle orientation. The orientation shown above has been randomly selected for the purpose of this example.

# DCM-H CONFIGURATION & SETUP

## STEP SIZE

The step size defines the minimum position change increment made by the drive. The standard step size setting is 0.1°, which produces the performance required for precision control. Typically, there is no need to adjust this parameter, but it can be increased through the DCM configuration. The maximum step size setting is 2.5°; however, this large a step size is typically unwarranted. It may be advantageous in certain applications where noise or other problems exist, to increase the step size slightly to prevent excessive modulation and wear to the drive and driven elements.

### Changing the Step Size

To select a Step Size using the HART Communicator, proceed through the following menus:

- Online
- > Functions
- > Configuration
- > Drive Setup
- > Step Size

Enter a desired value in degrees (between 0.1 and 2.5) and press the ENTER key. Remember to press the SEND key to execute the change.

## STALL PROTECTION

The DCM provides protection of the drive motor and gearing in the event of a stalled condition. The DCM accomplishes this by sensing that the drive is unable to balance for a set period of time known as the “stall time”. If the DCM is unable to balance the drive for a period greater than the stall time, it shuts off power to the motor to prevent the drive from continuing to operate against the stall and contacts at terminals 12 & 13 will open. Resetting the drive and restoring normal operation is achieved in several ways: Reversing the Demand signal to the drive, performing a stall reset procedure (see Manual Operation Menu on the foldout at the rear of the manual), performing a board reset procedure (see Diagnostics Menu on the foldout at the rear of the manual), or cycling the drive ac power.

### Changing Stall Time

To select a Stall Time using the HART Communicator, proceed through the following menus:

- Online
- > Functions
- > Configuration
- > Drive Setup
- > Stall Time

Enter a desired value in seconds (between 30 and 300) and press the ENTER key (the default setting is 300 seconds). Remember to press the SEND key to execute the change.

### WARNING

**It is possible that the stall time can be set to a value less than the full stroking time of Group 22 drives. This could lead to false stall conditions if the drive is stroked during setup.**

---

## POSITION FEEDBACK SIGNAL

The Feedback Sourcing module provides a mA analog output signal (typically 4–20 mA) that represents the drive output shaft position in terms of 0–100% of full rotational travel. This signal can be remotely monitored or used by a controller or indicator. The user has the option of enabling or disabling the signal. Normally, the signal should be enabled, but in a situation where the feedback is unused (i.e., not wired to a load) a HART alarm message will be present while communicating using the 275 Communicator. This message is helpful in alerting the user to open feedback wiring, but it is not useful when the feedback is purposely disconnected or unused. Disabling the feedback signal turns off the output and eliminates the message. It can also be eliminated by placing a load resistor (e.g., 250Ω) across the feedback terminals 16 & 17.

### Enabling / Disabling Position Feedback Signal

To enable or disable the Feedback signal using the HART Communicator, proceed through the following menus:

- Online
- > Functions
- > Configuration
- > Feedback Setup
- > Feedback

Select ENABLED or DISABLED and press the ENTER key. Remember to press the SEND key to execute the change.

## DEMAND SIGNAL CHARACTERIZATION

The Beck DCM is designed to receive a 4–20 mA (1–5 V dc) input Demand signal and respond by repositioning the drive output shaft in proportion to the signal. There are two ways in which the DCM can interpret the Demand signal: Linearly, or in a non-linear square relationship. The linear interpretation, which is most commonly employed, simply causes the drive to position the output shaft in a one-to-one relationship with the Demand. For example, a 1% change in Demand always causes a 1% position response. The square relationship produces a non-linear drive response proportional to the square of the Demand signal. For example, a 25% input Demand is interpreted as  $0.25^2$  or 0.0625 (6.25%). The square relationship helps to linearize response of final control elements that have quick opening characteristics.

### Changing Characterization

To change the characterization using the HART Communicator, proceed through the following menus:

- Online
- > Functions
- > Configuration
- > Demand Setup
- > Dem Curve

Select the desired characterization and press the ENTER key. Remember to press the SEND key to execute the change.

# DCM-H CONFIGURATION & SETUP

---

## LOSS OF DEMAND INPUT SIGNAL

The DCM has the capability of determining when the Demand input signal to the drive is lost, and then responding in the method most appropriate for the application. There are three setup parameters that must be configured in order to define this capability: “LOS mode”, “LOS pos”, and “DemLimLwr”. The “LOS mode” parameter determines how the drive should respond to the loss of the Demand input signal. It can be configured as “Stay” or “Go pos”, which means the drive holds its position when the signal is lost, or it goes to a predetermined position. If the “go pos” option is selected, the “LOS pos” parameter is used to determine what output shaft position the drive will achieve when the input is lost. Finally, a loss of signal is sensed by the DCM when the signal drops below the value set by the “Dem lwr lim” parameter. This value is entered in mA. If the Demand input signal drops below this value, the DCM senses a lost Demand input and executes the configured Loss of Signal action, and contacts at terminals 12 & 13 will open.

## Changing Loss (LOS) of Signal Action

To change the LOS signal mode using the HART Communicator, proceed through the following menus:

- Online
- > Functions
- > Configuration
- > Demand Setup
- > LOS Mode

Select the desired mode and press the ENTER key. Remember to press the SEND key to execute the change.

## Changing Loss (LOS) of Signal Position

To select the position that the drive will run to during a LOS condition (if the “Go-to-Pos” option is selected), use the HART Communicator and proceed through the following menus:

- Online
- > Functions
- > Configuration
- > Demand Setup
- > LOS Pos

Select the desired value in % and press the ENTER key. Remember to press the SEND key to execute the change.

## Changing LOS Trip Point

The default value for the LOS trip point is 5% of the signal span below the minimum span value (e.g., a 4–20 mA drive would have a LOS trip point of 3.2 mA). To change the LOS trip point using the HART Communicator, proceed through the following menus:

- Online
- > Functions
- > Configuration
- > Demand Setup
- > DemLimLwr

Select the desired value in mA and press the ENTER key. Remember to press the SEND key to execute the change.

## TORQUE OPTIONS

Group 22 DCMs have the capability to measure the drive's torque output and provide several torque related features. These features include a live display of the torque output on the 275 HART Communicator display (or any other device capable of communicating and displaying HART transmitted variables). Peak torque values are stored within the DCM and viewed by accessing the Statistics menu. To protect the drive gearing and related equipment, the drive can be configured to shut off if the torque exceeds 115% of the drive torque rating, by enabling over-torque protection. And finally, the DCM provides a high torque alarm, via HART communications, that alerts the user to a high torque condition when the torque output exceeds a set value (normally set at 105% of the drive rating), and contacts at terminals 12 & 13 will open.

The torque features of the drive can be enabled or disabled using the "Trq Snsr" menu item.

### Enabling/Disabling Torque Sensing

To enable or disable torque sensing using the HART Communicator, proceed through the following menus:

- Online
- > Functions
- > Configuration
- > Torque Setup
- > Trq Snsr

Select Enabled or Disabled and press the ENTER key. Remember to press the SEND key to execute the change.

### Enabling/Disabling Over-torque Protection

To enable or disable over-torque protection using the HART Communicator, proceed through the following menus:

- Online
- > Functions
- > Configuration
- > Torque Setup
- > Ovt Prot

Select Enabled or Disabled and press the ENTER key. Remember to press the SEND key to execute the change.

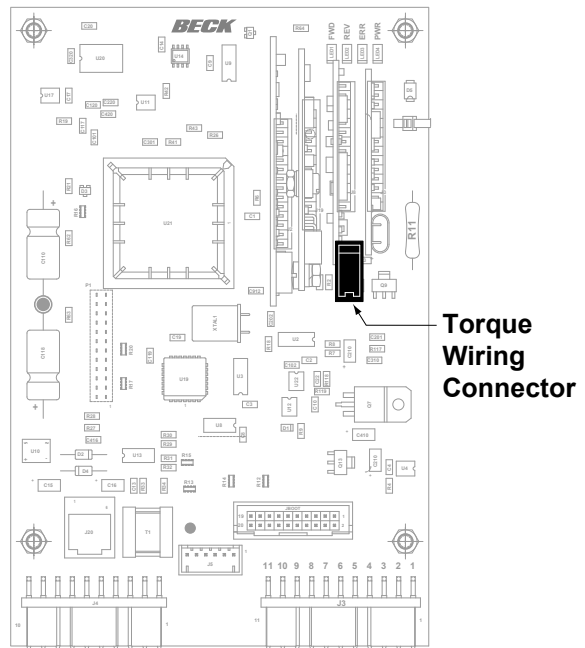

**DCM-H Board showing location of Torque Wiring Connection  
(Location is the same on the DCM-L Board)**

# DCM-H CALIBRATION RANGE SELECTION

## CPS SIGNAL RANGE

In order for the drive to position properly, the DCM must be configured with the CPS voltages that correspond to the voltage at 0 degrees (CPS Zero) and the voltage span for 100 degrees rotation (CPS Span). The value of CPS Zero is typically 1.300 volts and CPS Span is typically 2.400 volts. If the CPS has been changed, these values may require adjustment. To check if these signal ranges are correct:

Run the drive to the exact 0 degree position (this is the 0% position).

Place Handswitch in STOP.

Read the voltage displayed by the HART Communicator at menu location:

- Online
- > Functions
- > Present Status
- > Raw Pos

Compare the voltage displayed by the HART Communicator at menu location:

- Online
- > Functions
- > Configuration
- > Position Setup
- > CPS Zero

If the readings are different by more than 0.005 volts, updating of the CPS Zero value may be desirable. To enter a new value, select the CPS Zero value and enter the voltage that was displayed at Raw Pos. Remember to press the SEND key to execute the change.

Run the drive to the exact 100 degrees position (this is the 100% position on drives set for 100 degrees of travel).

Place Handswitch in STOP.

Read the voltage displayed by the HART Communicator at menu location:

- Online
- > Functions
- > Present Status
- > Raw Pos

Subtract the CPS Zero voltage reading from the Raw Pos voltage reading at the 100 degrees position.

Compare the voltage displayed by the HART Communicator at menu location:

- Online
- > Functions
- > Configuration
- > Position Setup
- > CPS Span

If the readings are different by more than 0.015 volts, updating of the CPS Span value may be desirable. To enter a new value, select the CPS Span value and enter the result calculated above. Remember to press the SEND key to execute the change.

## DEMAND INPUT SIGNAL RANGE

In order for the drive to properly follow the Demand input signal, the DCM must be configured with the Demand values that correspond to 0% and 100%. The most common value for 0% is 4 mA, and for 100% is 20 mA. The value for 0% must be greater than 0.5 mA and the value for 100% must be less than 21 mA. The difference between 0% and 100% must be at least 4 mA.

To check or set the 0% value (Demand Range Lower) using the HART Communicator, proceed through the following menus:

- Online
- > Functions
- > Configuration
- > Demand Setup
- > DemRngLwr

If the existing value is not appropriate, enter the desired value in mA and press the ENTER key. Remember to press the SEND key to execute the change.

To check or set the 100% value (Demand Range Upper) using the HART Communicator, proceed through the following menus:

- Online
- > Functions
- > Configuration
- > Demand Setup
- > DemRngUpr

If the existing value is not appropriate, enter the desired value in mA and press the ENTER key. Remember to press the SEND key to execute the change.



## Split Range Operation

Split range operation is a technique which allows two or more drives to operate from one signal source. To set up two or more drives for split range operation, connect the Demand input signals of each drive in parallel. The DCM R11 resistor (see illustration below) must be removed from all but one drive. Decide the appropriate Demand signal range for each drive and refer to the Demand Input Signal Range section detailed on page 32.

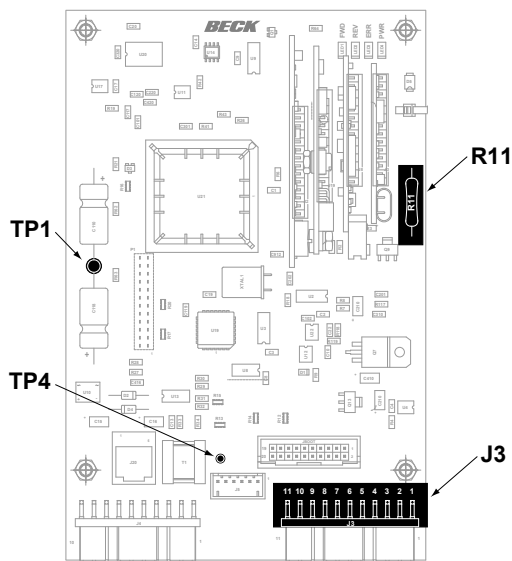

**DCM-H Board showing Resistor R11,  
Connector J3 and Test Points 1 & 4  
(Locations are the same on the DCM-L Board)**

## FEEDBACK OUTPUT SIGNAL RANGE

In order for the drive to supply the appropriate Feedback signal, the DCM must be configured with the Feedback values that correspond to 0% and 100%. The most common value for 0% is 4 mA, and for 100% is 20 mA. The value for 0% must be greater than 3 mA and the value for 100% must be less than 21 mA. The difference between 0% and 100% must be at least 4 mA.

To check or set the 0% value (Feedback Range Lower) using the HART Communicator, proceed through the following menus:

- Online
- > Functions
- > Configuration
- > Feedback Setup
- > FBRngLwr

If the existing value is not appropriate, enter the desired value in mA and press the ENTER key. Remember to press the SEND key to execute the change.

To check or set the 100% value (Feedback Range Upper) using the HART Communicator, proceed through the following menus:

- Online
- > Functions
- > Configuration
- > Demand Setup
- > FBRngUp

If the existing value is not appropriate, enter the desired value in mA and press the ENTER key. Remember to press the SEND key to execute the change.

## TORQUE SENSOR RANGE SETUP

In order for the drive to properly measure Torque, the DCM must be configured with the Torque sensor values that correspond to 0% and 100%. These values are unique to each drive and are labeled inside the DCM electronics compartment on the drive body wall. These values are also available from the factory.

When replacing the DCM for any reason, the torque values must be checked and reset to the values labeled in the drive for proper operation.

To check or set the 0% value (Trq Null) using the HART Communicator, proceed through the following menus:

- Online
- > Functions
- > Configuration
- > Torque Setup
- > Trq Null

If the existing value is not appropriate, enter the appropriate value and press the ENTER key. Remember to press the SEND key to execute the change.

To check or set the 100% value (Trq Const) using the HART Communicator, proceed through the following menus:

- Online
- > Functions
- > Configuration
- > Torque Setup
- > Trq Const

If the existing value is not appropriate, enter the appropriate value and press the ENTER key. Remember to press the SEND key to execute the change.

# DCM-H CALIBRATION SIGNALS

---

## WARNING

**If recalibrating, be aware that the drive will be required to reposition. Additionally, as with any change in the DCM configuration, the drive may reposition when restored to normal operation.**

This section is for trimming signals for accuracy; refer to pages 32–33 for instructions to set signal ranges.

## INTERNAL POSITION CALIBRATION

This calibrates the circuits that measure the CPS internal position signal, which is not available at the customer terminal block. This signal is calibrated at the factory and recalibration should not be necessary. To check if calibration is required:

Place Handswitch in STOP.

Measure the voltage (Vdc) on the control board between test points 1 (–) and 4 (+) (see figure on page 33 for location of test points).

Compare the voltage to the value displayed by the HART Communicator at menu location:

- Online
- > Functions
- > Present Status
- > Raw Pos

If the readings are different by more than 0.025 volts, recalibration may be desirable. To recalibrate, select the “Raw Pos” value and enter the voltage measured between test points 1(–) and 4(+) (see figure on page 33 for location of test points).

## DEMAND SIGNAL CALIBRATION

This calibrates the circuits that measure the Demand input signal. This signal is calibrated at the factory and normally does not require recalibration; however, some users may want to do so to account for slight variations between the drive calibration and their own instrument calibration. To check if calibration is required:

Place Handswitch in STOP.

Supply a 4.00 mA signal to the customer terminal block at terminals 14(–) and 15(+).

Compare 4.00 mA to the value displayed by the HART Communicator at menu location:

- Online
- > Functions
- > Present Status
- > Loop(Dem)

If the readings are different by more than 0.03 mA, recalibration may be desirable. To recalibrate, select the “Loop(Dem)” value and enter 4.00 mA.

Supply a 20.00 mA signal to the customer terminal block at terminals 14(–) and 15(+).

Compare 20.00 mA to the value displayed by the HART Communicator at menu location:

- Online
- > Functions
- > Present Status
- > Loop(Dem)

If the readings are different by more than 0.03 mA, recalibration may be desirable. To recalibrate, select the “Loop(Dem)” value and enter 20.00 mA.

## FEEDBACK SIGNAL CALIBRATION

This calibrates the circuits that create the customer Feedback signal (available at terminals 16 and 17). This signal is calibrated at the factory, but recalibration to correspond to customer instrumentation may be desirable. To check if calibration is required:

Note: These steps require the Feedback signal range to be set to 4.00–20.00 mA.

Run the drive to the 0% travel position.

Measure the mA signal at terminals 16(–) and 17(+), using a high accuracy meter.

Compare the reading to the value displayed by the HART Communicator at menu location:

- Online
- > Functions
- > Present Status
- > Feedback

If the readings are different by more than 0.03 mA, recalibration may be desirable. To recalibrate, select the “Feedback” value and enter the meter reading.

Run the drive to the 100% travel position.

Measure the mA signal at terminals 16(–) and 17(+), using a high accuracy meter.

Compare the reading to the value displayed by the HART Communicator at menu location:

- Online
- > Functions
- > Present Status
- > Feedback

If the readings are different by more than 0.03 mA, recalibration may be desirable. To recalibrate, select the “Feedback” value and enter the meter reading.

# DCM-H COMMUNICATION

## 275 HANDHELD COMMUNICATOR WIRING CONNECTIONS

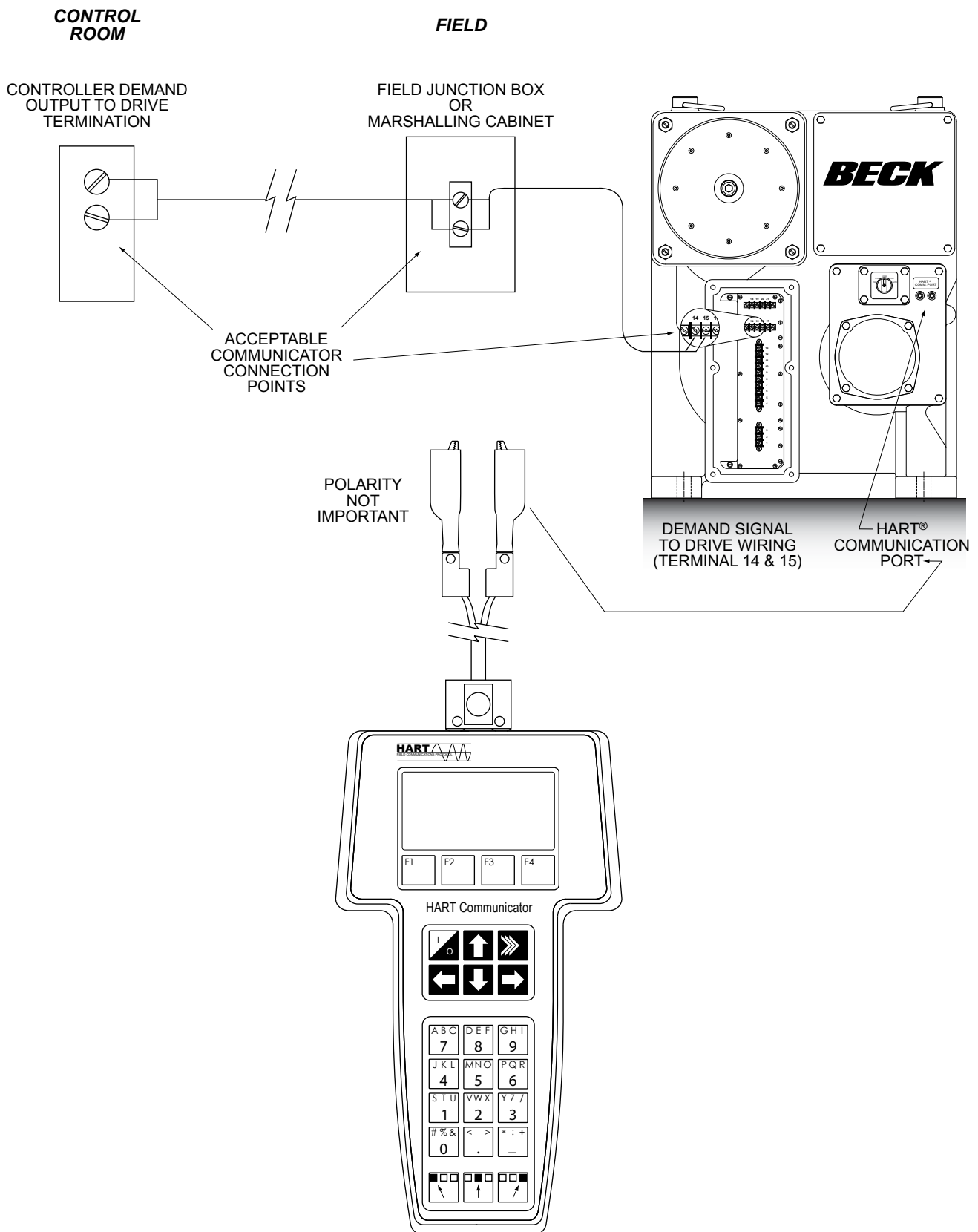

# DCM-H COMMUNICATION

---

The DCM is the control center of the drive. Drive configuration and calibration are accessed and set through the DCM. Interfacing to the board requires a HART compatible communicator. Typically, a universal model 275 HART communicator is used, but any device, computer or controller capable of communicating with HART devices and supporting the Beck DCM device description can be used. **This instruction only covers the model 275 HART Communicator.**

## HART INTERFACE

The foldout at the end of the manual displays the interface menu tree for communicating with a DCM via a model 275 HART communicator. This menu tree displays all the possible setup options, features and available information. Some of the features may not be available. If a particular feature is not available, a message to that effect will be displayed when an attempt to access or change the feature is made.

## USING THE 275 COMMUNICATOR

The universal model 275 HART Communicator leads should be connected to the drive's HART communication port (see page 4). This allows the communicator to simultaneously communicate over the analog input wires. This does not disturb the analog command signal, or disrupt the DCM functions. However, any program changes to the DCM will momentarily suspend the operation of the module (maintains last state) while the change is implemented. Typically, this is only for a second or two.

With the communicator connected, turn on the communicator and wait for communications to be established. Once communicating, the "Online" display (foldout, menu block #1) will appear in the communicator window. If the drive is multidropped with other devices on a single HART network, the first display screen will list all devices and require a selection before the "Online" display is shown. The "Online" display provides online information about the present drive operating conditions. Entering any of the menus shown in the foldout is accomplished by following the display and using the communicator's arrow keys. **If the communicator is unable to communicate with the DCM, it will display the message, "No Device Found". If this occurs, ensure that the communicator is securely connected to the drive's HART communication port, and**

**retry. If communications still do not occur, the communicator polling setup may be improperly set. Check the "utility" menu and make sure communications polling is set to "always poll".**

The communicator keypad and display is shown on page 35. There are four sections: 1) the liquid crystal message display, 2) four function keys beneath the LCD display, 3) six navigational keys in the center section, 4) alphanumeric entry keys at the bottom.

The LCD displays all the information and actions available. In addition to the 21 character display that provides the communication between the user and the Beck drive, the bottom line of the LCD displays dynamic labels that define the purpose of the function keys directly below each label.

The function keys are used to perform certain actions such as entering settings, accessing help screens, sending commands, paging up and down within methods, and exiting methods. The function of each key may change depending on the menu or method selected. As functions change, so do the dynamic labels in the LCD.

The six navigational keys consist of a black and white on/off key, four blue and white arrow keys, and a single "hot key". The hot key is not used for Beck drive applications, but can be configured by the user to select menus most often accessed. The right arrow key has two functions. It moves the cursor to the right when making or editing an entry, and it also is used to select a new menu. The left arrow key moves the cursor to the left and also backs out to a previous menu. Combined, these keys allow movement between menus as shown in the foldout.

The alphanumeric keys are used to type in entries. Whenever a selected menu or method requires a value or description to be entered, this keypad is used. Since each key represents four different characters, three shift keys are provided at the bottom of the pad. A particular alphanumeric character is selected by pushing the appropriate shift key then pushing the alphanumeric key.

Before moving on, it may be helpful to practice with the communicator. Connect the communicator as described, turn it on and establish communications. Then use the arrow keys to move through the various menus as shown in the menu tree (the foldout).

## MENU DESCRIPTIONS

(A foldout of the menu structure is located at the end of the manual for easy reference).

### Online Menu (Foldout, block 1)

```
BECK-DCM:FCU-1000
Online
1 Functions
2 Position 18.26 %
3 Demand 18.14 %
4 Loop(Den) 6.90 mA
5 Torque 11 %
SAVE
```

When communications are established with the communicator, the “Online” menu is displayed. This menu is the gateway to all the other menus and it also provides current information about the drive. Numbered items 2 through 7 provide live, dynamic values of the drive’s output position in percent, the Demand signal to the drive in percent, the Demand signal in milliamps, the torque output of the drive in percent, the drive temperature and the external position feedback signal in milliamps. Select the first menu item, “Functions” (by first highlighting it and then using the right arrow key to select it), to gain access to the Functions menu. By backing out of the Online menu using the left arrow key, selection of the “Offline” menu is accomplished.

### Offline Menu (Foldout, block unmarked)

```
HART Communicator
1 Offline
2 Online
3 Frequency Device
4 Utility
```

The Offline menu applies only to the 275 HART Communicator setup and configuration. This, and the many submenus that exist, are typical to all model 275 HART Communicator applications. **It is unlikely that it will be necessary to consult this menu unless it is impossible to establish communications with the drive; in which case the “Utility” menu should be selected.** Once within the “Utility” menu, use the right arrow key to select “Configure Communication”, then “Polling”, and finally “Always Poll”. Use the ENTER function key to select “Always Poll”. Back out to the main “Offline” menu using the left arrow key. Once at the main menu, select “Online” and use the right arrow key to return to the Online menu.

### Functions Menu (Foldout, block 2)

```
BECK-DCM:FCU-1000
Functions
1 Setup Assistant
2 Device Information
3 Configuration
4 Statistics
5 Present Status
HELP SAVE DONE
```

From the Functions menu, any of the DCM functional menus can be selected and accessed. Essentially, there are seven functional areas which include: Setup Assistant, Device Information, Configuration, Statistics, Present Status, Manual Operation and Diagnostics.

The “**Setup Assistant**” (foldout, block 3) is actually a procedure that allows the user to setup all the details necessary to get the drive up and running as desired. It sequentially walks the user through a series of questions and entries that enable the drive to be rapidly and completely setup. This method is entirely self-driven, and the user need only follow the questions and prompts to successfully complete the setup. Because control drives are set up at the factory according to customer specifications, it is normally not necessary to go through the Setup Assistant.

The other functional areas and menus are described in more detail as follows.

### Device Information Menu (Foldout, block 4)

```
BECK-DCM:FCU-1000
Device Information
1 Tag FCU-1000
2 Descriptor
3 Message
4 InstId 12/20/2001
5 Setup 01/04/2002
HELP SAVE DONE
```

The Device Information menu is strictly an informational page. By entering this menu, a selection of useful information can be viewed and/or edited. There are a total of nine information entries:

1. **Tag** - This 8 character entry can be edited to reflect the loop tag number/name.
2. **Descriptor** - This entry is a 16 digit field that can be used to provide any description the user desires. This entry is normally blank when shipped from the factory unless the user specifies a description prior to shipment. The user can edit the field if desired.

# DCM-H COMMUNICATION

## DEVICE INFORMATION MENU, CONT'D.

3. **Message** - This entry is a 32 digit field that can be used to provide any message the user desires. This entry is normally blank when shipped from the factory unless the user specifies a message prior to shipment. The user can edit the field if desired.
4. **Instld** - This is a date entry that is normally used to indicate the date that the drive or DCM was installed. The date format is mm/dd/yyyy and it can be fully edited.
5. **Setup** - This is a date entry that is normally used to indicate the date that the DCM/drive setup was performed. Although this entry is viewed and can be edited in the "Device Information" menu, the user is prompted at the end of performing a "setup" to enter a date. Entering the date at the prompt automatically updates the date displayed. The date format is mm/dd/yyyy and it can be fully edited.
6. **Calbrtd** - This is a date entry normally used to indicate the date that the DCM/drive was last calibrated. Although this entry is viewed and can be edited in the "Device Information" menu, the user is prompted at the end of performing any "calibration" method to enter a date. Entering the date at the prompt automatically updates the date displayed. The date format is mm/dd/yyyy and can be edited.
7. **Model** - This entry displays the model number of the drive in which the DCM is installed. It normally is set at the factory when the DCM is installed in a drive. The user can edit the field if desired.
8. **Drive S/N** - This entry displays the serial number of the drive in which the DCM is installed. It normally is set at the factory when the DCM is shipped in a drive. If the DCM is shipped as a spare or replacement part, the "Drive S/N" field will be blank. The user can edit the field if desired.
9. **Poll Addr** - This entry can be edited; however, it is normally set to 0. A polling address from 1 to 15 can be entered if the drive resides on a common HART network with other HART devices.

A final available selection is "**Review**" (foldout, block 4A). Selecting this item using the right arrow key allows for a quick scroll through all nine device information items, as well as all the other DCM settings, without accessing each item individually. This is an excellent tool for quickly determining how a particular drive is setup. To edit individual entries, the user must exit review and go to the appropriate menu and item.

## Configuration Menu (Foldout, block 5)



The Configuration menu serves as the gateway to all of the drive operating setup parameters. The user can select any of five different setup submenus that can be used to configure the drive based on the physical layout and the desired operation.

Also available under Configuration is the "Restore to Factory" walk-through procedure which may be used to set the DCM back to its original setup (as shipped from the factory) and calibration. By selecting the "Restore to Factory" procedure, every drive operating parameter that may be edited, along with all calibrations, are returned to their factory settings.

The five setup submenus are as follows:

## Drive Setup Menu (Foldout, block 5A)



This menu is used to set drive operating parameters. The five parameter entries are as follows:

1. **Drive Dir** - This parameter is used to select the rotation direction of the drive. The options available are clockwise rotation (CW Incr), or counterclockwise rotation (CCW Incr). Direction of travel always refers to the rotation of the drive output shaft, given an increasing Demand signal, looking into the output shaft (see figure on page 27).

When the direction of travel parameter is changed, the DCM automatically reverses the analog position feedback signal such that it is 4 mA at the 0% input signal position and 20 mA at the 100% position. This parameter is normally set to CW unless the user specified CCW prior to shipment of the drive. For editing procedure, see page 27.

2. **Deg Rot** - This value is typically set for 100.00 degrees of travel in response to the 0–100% Demand input signal. This value may be changed to as little as 60.00 degrees, if necessary (see “Reducing Full Rotation”, page 27).
3. **Step Size** - This value sets the typical minimum step size for output shaft movements expressed in degrees. Values between 0.1 degrees and 2.5 degrees may be selected (see “Changing the Step Size, page 28).
4. **Stall time** - The DCM provides stall protection to the entire drive by shutting off power to the motor and providing a HART alarm. This entry allows the stall time required to trigger the stall protection to be configured. At the factory it is normally set to 300 seconds, but can be edited and set for any value between 30 and 300 seconds. For editing procedure, see page 28.
5. **LimitSwitch** - This setting defines whether contacting a limit switch, outside the normal travel range of 0% to 100%, will cause an alarm condition. Two settings may be selected, either Accept or Alert. If the Accept option is selected, contacting a limit switch will not cause an alarm condition; and if the Alert option is selected, then an alarm condition will occur if a limit switch is contacted.

## Position Setup Menu (Foldout, block 5B)



This menu is used to perform the position sensor setup. The four parameter entries are as follows:

1. **CPS Zero** - This sets the value of the signal, in volts, from the CPS that corresponds to the 0 degree output shaft position, typically 1.3 volts. For editing procedure, see page 32.
2. **CPS Span** - This sets the value of the signal span, in volts, from the CPS that corresponds to 100 degrees of output shaft travel; typically 2.4 volts. For editing procedure, see page 32.
3. **Pos S/N** - This parameter displays the serial number of the position sensor installed in the drive. New drives will have this information entered at the factory. DCMs shipped as spare parts will have this entry left blank. The

user can enter the appropriate information if desired, but it is not required.

4. **Snsr Dir** - This parameter displays the position sensor rotation (i.e., the direction in which the drive output shaft rotates to increase the position sensor output signal). This value cannot be edited. Typically, all new drives built with a DCM use CW rotation for increasing position signal (CW Incr).

## Demand Setup Menu (Foldout, block 5C)

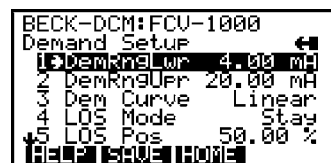

This menu is where all the Demand input signal related drive parameters are set. The seven parameter entries are as follows:

1. **DemRngLwr** - This parameter is used to set what the DCM interprets as the lower range of the Demand input signal. This value may be edited to accommodate split ranging up to four drives. For editing procedure, see page 32.
2. **DemRngUpR** - This parameter determines what the DCM interprets as the upper range of the Demand input signal. This value may be edited to accommodate split ranging up to four drives. For editing procedure, see page 32.
3. **Dem curve** - This is a dual choice entry that is used to set the Demand input characterization. The two characterization choices are “Linear” and “Square”. Linear means that the Demand signal is interpreted linearly and the drive responds to the Demand with a linear relationship. The square setting means that the Demand signal is interpreted with a square function and the drive output positions in a square relationship with respect to Demand. For example, at 25% Demand the drive position equals  $0.25^2$  or 0.0625 (6.25%). At Demands of 50%, 75% and 100% the position would be 25%, 56.25%, and 100% respectively. This nonlinear curve can be used to compensate for valves and dampers with quick opening characteristics. This entry will always be set to linear by the factory unless otherwise specified by the user. For editing procedure, see page 29.

# DCM-H COMMUNICATION

## DEMAND SETUP MENU, CONT'D.

- LOS Mode** - This parameter is used to set the drive action upon loss of the Demand input signal. Two options are available: "Stay" or "Go-to-Pos". Selecting the "Stay" option configures the drive such that the output shaft will stay in its last position if the Demand signal is lost for any reason. Selecting the "Go-to-Pos" option configures the drive to move to a predetermined position (see **LOS Pos** below) upon loss of the Demand signal. This parameter is set to "Stay" by the factory, unless otherwise specified by the user. For editing procedure, see page 30.
- LOS Pos** - This parameter is used to set the predetermined position when the LOS mode described above is set to "Go-to-Pos". This parameter is normally shipped from the factory set at 50.00%, but it has no effect on loss-of-signal action unless the "Go-to-Pos" option is selected. The value can be edited and set anywhere between -5% and 105%. For editing procedure, see page 30.
- DemLimLwr** - This parameter is used to set what the DCM interprets as the lower limit of the Demand input signal range. Input signals below this setting are interpreted by the DCM as a lost signal, and the LOS mode function takes over drive operation.
- DemLimUpr** - This parameter determines what the DCM interprets as the upper limit of the Demand input signal range.

## Feedback Setup Menu (Foldout, block 5D)

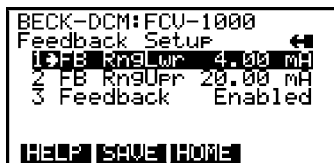

This menu provides access to the feedback parameters. The three parameters are as follows:

- FB RngLwr** - This sets the value of the feedback signal, in mA, that corresponds to a 0% output shaft position. For editing procedure, see page 33.
- FB RngUpr** - This sets the value of the feedback signal, in mA, that corresponds to a 100% output shaft position. For editing procedure, see page 33.
- Feedback** - This parameter is used to either enable or disable the external analog feedback signal.

## Torque Setup Menu (Foldout, block 5E)

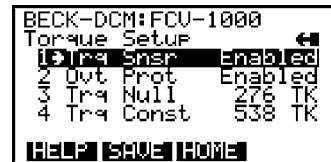

This menu provides access to the torque measurement related parameters. The four parameters are as follows:

- Trq Snsr** - This parameter is used to enable or disable the torque measurement feature of the DCM.
- Ovt Prot** - If the torque sensor is enabled, the DCM has the ability to remove power from the motor in the event that the torque output of the drive exceeds 115% of its rated output. This parameter is used to enable or disable this feature. For editing procedure, see page 31.
- Trq Null** - This parameter is determined during the construction of the drive. For editing procedure, see page 33.
- Trq Const** - This parameter is determined during the construction of the drive. For editing procedure, see page 33.

## Restore to Factory (Foldout, block 5F)

"Restore to Factory" is a procedure that returns many of the drive's settings back to their original (as shipped from the factory) setup. The items restored include: Model, Drive Dir, Deg Rot, Step Size, Stall Time, LimitSwitch, CPS Zero, CPS Span, DemRngLwr, DemRngUpr, Dem Curve, LOS Mode, LOS Pos, DemLimLwr, FB RngLwr, FB RngUpr, Feedback, Trq Snsr, Ovt Prot, Trq Null, Trq Const, Line Freq, Raw Pos trim value, Loop(Dem) trim values, Feedback trim values, Expansion 1, Expansion 2, Max Error, Power, and Max Freq.



## Statistics Menu (Foldout, block 6)

```

BECK-DCM:FCU-1000 0
Statistics ←
1 Starts 1
2 Reversals 1
3 Stalls 10
4 Overtorqs 10
5 Peak Torq 12 %
HELP SAVE HOME
  
```

This menu is where all the drive's stored operating statistics are available. There is a total of eight different statistics available. The eight statistics are as follows:

1. **Starts** - This statistic logs and displays the total number of starts the drive motor has made.
2. **Reversals** - This statistic logs and displays the total number of reversals the drive motor has made.
3. **Stalls** - This statistic logs and displays the total number of stalled conditions the drive has experienced. For the drive to register a stall, the DCM must be unable to balance the drive position against the Demand input signal for a period exceeding the **Stall time** set in the Drive Setup menu.
4. **Overtorqs** - This statistic logs and displays the total number of overtorque conditions that have occurred. An overtorque condition results when the drive output torque exceeds the torque limit value.
5. **Peak Torq** - This statistic displays the highest absolute torque value in percent of rating measured by the drive.
6. **Run Time** - This statistic logs and displays the total run time of the drive motor in seconds.
7. **High Temp** - This statistic logs and displays the highest temperature in degrees Fahrenheit measured by a temperature sensor resident on the DCM.
8. **Low Temp** - This statistic logs and displays the lowest temperature in degrees Fahrenheit measured by a temperature sensor resident on the DCM.

## Present Status Menu (Foldout, block 7)

```

BECK-DCM:FCU-1000
Present Status ←
1 LED Status
2 Switch Status
3 Local Cntrl Status
4 CM1 Inhibitors
5 CM2 Inhibitors
HELP SAVE HOME
  
```

This menu is where the drive's current operating status is displayed. There are sixteen status indicators available, and six of these show tabulated data as follows:

## LED Status (Foldout, block 7A)

```

BECK-DCM:FCU-1000
LED Status
ERR OFF
REV OFF
FWD OFF
HELP SAVE HOME
  
```

This display is where the status of the DCM LEDs is available. Each of the LEDs listed will display either an "OFF" or "ON" status. The LEDs listed are: Error, Reverse and Forward.

## Operating Status (Foldout, block 7B)

```

BECK-DCM:TEST
Operating Status
Dem <> Limits OFF
Pos <> Limits OFF
Temp <> Limits OFF
Torq <> Limits OFF
Over-Torq Stop OFF
HELP SAVE HOME
  
```

This display provides detailed status of the drive and process alarm conditions. A number of problems can occur that may result in an alarm condition. These problems include: Demand signal out of limits, position signal out of limits, temperature beyond drive rating, torque beyond drive rating, torque greater than torque alarm level, drive stalled, feedback circuit is open, or main power voltage is low. This display lists all these possible problems that activate the alarm condition. Each of the problems will display either an "OFF" or "ON" status. One or more problem(s) displaying the "ON" status means that each are responsible for the alarm condition.

# DCM-H COMMUNICATION

## Switch Status (Foldout, block 7C)

```
BECK-DCM:FCU-1000
Switch Status
Limit CCW      OFF
Limit CW       OFF
OvrRd CCW     OFF
OvrRd CW       OFF
OvrRd STOP    OFF
```

This display shows the status of the drive's switches. Each of the switches listed will display either an "OFF" or "ON" status. The switches listed are: The CW and CCW over-travel limit, the CCW, CW and STOP overrides, the CCW, CW and AUTO Handswitch.

## Local Control Status (Foldout, block 7D)

```
BECK-DCM:FCU-1000
Local Cntrl Status
STATUS CHECK   OFF
SET POS 100%  OFF
SET POS 0%    OFF
SET DEM 100%  OFF
SET DEM 0%    OFF
```

This block is currently non-functional and is reserved for future use.

If your DCM is also equipped with a customer interface panel, this display shows the status of the DCM local functions. Each of the pushbuttons listed will display either an "OFF" or "ON" status. The pushbuttons listed are: STATUS CHECK, SET POS 100%, SET POS 0%, SET DEM 100%, and SET DEM 0%.

## CW Inhibitors (Foldout, block 7E)

```
BECK-DCM:FCU-1000
CW Inhibitors
Balance        ON
Supervisory    OFF
Stall          OFF
Overtorque     OFF
Bad Pos Sig    OFF
```

This display provides information about the clockwise (CW) motor control status. Any number of conditions can occur to inhibit the output shaft from driving in the CW direction. These conditions include: The drive is at balance, a supervisory condition, a stall protection condition, an over-torque protection condition, a failed position signal, a failed Demand signal, a Handswitch override, limit switch condition, or a local calibration is in process. This display lists all these possible inhibiting conditions that prevent the drive shaft from driving in the CW direction. Each of the conditions will display either an "OFF" or "ON" status. One or more conditions displaying the "ON" status means that those conditions are currently preventing the drive from driving its output shaft in the CW direction.

## CCW Inhibitors (Foldout, block 7F)

```
BECK-DCM:FCU-1000
CCW Inhibitors
Balance        ON
Supervisory    OFF
Stall          OFF
Overtorque     OFF
Bad Pos Sig    OFF
```

This display provides information about the counterclockwise (CCW) motor control status. Any number of conditions can occur to inhibit the output shaft from driving in the CCW direction. These conditions include: The drive is at balance, a supervisory condition, a stall protection condition, an over-torque protection condition, a failed position signal, a failed Demand signal, a Handswitch override, limit switch condition, or a local calibration is in process. This display lists all these possible inhibiting conditions that prevent the drive shaft from driving in the CCW direction. Each of the conditions will display either an "OFF" or "ON" status. One or more conditions displaying the "ON" status means that those conditions are currently preventing the drive from driving its output shaft in the CCW direction.

## Manual Operation Menu (Foldout, block 8)

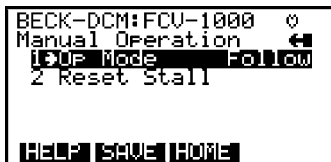

This menu is used to allow manual drive operation with the HART communicator. There are two manual operation procedures available. They are as follows:

1. **Op mode** - This procedure allows the user to select the operating mode of the DCM. There are four possible choices: "Follow", "Hold", "RunCW", "RunCCW". The "Follow" mode is the normal state of operation and allows the DCM to control the drive operation by responding to the analog input Demand signal when the drive Handswitch is in the AUTO position. The "Hold" mode forces the DCM to maintain the drive output shaft position regardless of the input Demand signal. The user can select to hold the position just where it is, or alternately provide the drive a position to run to and hold. The "RunCW" and "RunCCW" modes of operation simply cause the drive to run to its CW and CCW extremes respectively, and hold.
2. **Reset stall** - This procedure resets normal drive operation after a stall condition has caused the drive to shut down. Selecting this option and following the prompts will restore operation. Note that stall conditions can also be reset by simply reversing the input Demand signal or cycling the drive ac power.

## Diagnostics Menu (Foldout, block 9)

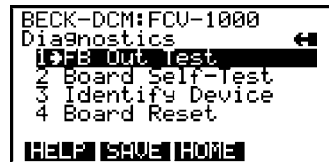

This menu provides access to four procedures that allow the user to test and reset the DCM. They are as follows:

1. **FB Out Test** (foldout, block 9A) - This procedure allows the user to test the position feedback output signal. Following the prompts through this procedure allows the user to verify the output signal value.
2. **Board Self-Test** (foldout, block 9B) - This procedure runs an automatic test that verifies the "health" of the DCM. It runs a checksum memory test and checks for the proper installation of the position sensor (CPS rotor). Running the test causes the drive to reposition temporarily, so it should only be run offline. The CPS test runs automatically as part of some calibration and setup procedures. Unless a DCM problem is suspected, there are few reasons to implement this test.
3. **Identify Device** (foldout, block 9C) - This procedure causes the ACKNOWLEDGE LED to flash for two seconds on drives equipped with the Local Control option. It can be used to identify the drive if it is multidropped with other devices on a single Hart network.
4. **Board Reset** (foldout, block 9D) - This procedure resets the board without powering down the drive. There are many communicator procedures that implement the reset procedure automatically to ensure the proper initialization of the DCM; however, few reasons to manually implement the reset procedure should arise.

# DCM-H COMMUNICATION

---

## COMMON HART MESSAGES

HART protocol maintains both standard and device specific informational messages that are displayed on the 275 handheld communicator when various conditions occur. They can also be used to trigger alarms and messages in other HART compatible monitoring systems. These messages alert the user to various alarm conditions and make it much easier to diagnose problems. Below is an explanation of typical HART Communicator messages and message sequences. It does not include all possible messages, only the most common.

### Demand Signal and Process Variable Messages

Message	Description
“Process applied to the non-primary variable is outside the operating limits of the field device”	This is a standard HART-defined message that appears whenever one of the three HART non-primary variables (Demand signal, Torque, Temperature) are outside their design or calibrated ranges.

### Position Signal Messages

*(The position signal is defined as the signal from the position sensor (CPS) to the DCM)*

Message	Description
“Process applied to the primary variable is outside the operating limits of the field device”	This is a standard HART-defined message that appears whenever the HART primary variable (Position signal) is outside the design or calibrated range.
“Analog output 1 and its digital representation are outside the operating range limits, and not responding to input”	This is an additional standard HART-defined message that appears whenever the HART primary variable (Position signal) is outside the design or calibrated range. It accompanies the message above.

# DCM-L CONFIGURATION & SETUP

**NOTE:** These instructions are applicable to drives equipped with the DCM-L only. The instructions on pages 27–44 are applicable to drives equipped with the DCM-H only.

## DCM-L OPERATION

The DCM-L customer interface panel (pictured below) allows the user to easily calibrate the drive and troubleshoot conditions. The following information will provide an overview of the DCM customer interface panel features.

**NOTE:** Beck drives are shipped from the factory set up and calibrated to customer specifications placed at the time of order and are ready for installation.

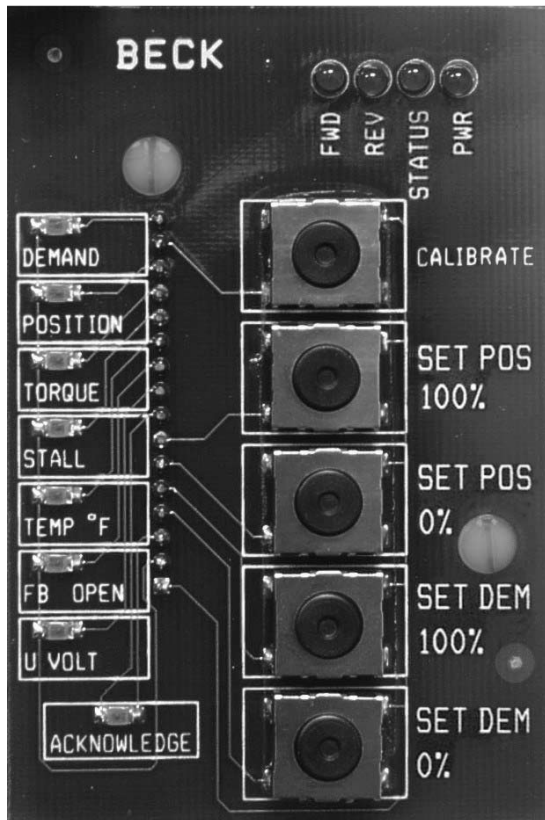

## Overview LEDs

The four LEDs, as highlighted below, indicate the present state of the drive. Note that when the Handswitch is in the CW or CCW position, the FWD and REV LEDs represent the drive movement corresponding to the Handswitch position.

### FWD

This LED is lit when the Handswitch is in STOP or AUTO, and the drive is receiving a Demand signal greater than its position.

### REV

This LED is lit when the Handswitch is in STOP or AUTO, and the drive is receiving a Demand signal smaller than its position.

### STATUS

This LED is lit when additional status is available. For details regarding possible conditions, see “Status Indication LEDs” on page 46.

### PWR

This LED is lit when power is applied to the drive.

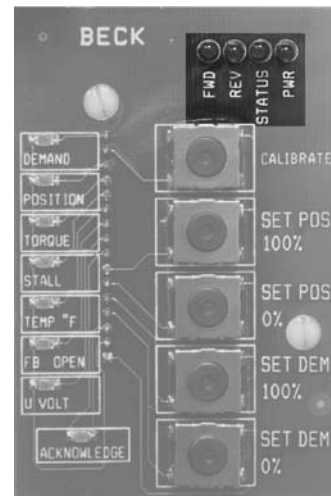

# DCM-L CONFIGURATION & SETUP

## Status Indication LEDs

When the “STATUS” LED is lit, the applicable status indication alarm LED(s) (pictured below) will light to reveal the condition(s) as described below. When the condition is corrected, the status will automatically reset. Each status LED is described below, with a more detailed explanation of the function provided on page 47.

### DEMAND

Loss of the Demand input signal.

### POSITION

The Position signal to the DCM from the CPS is out of the calibrated range limits. The lower limit is -5% and the upper limit is 105% of the calibrated range. This LED being lit may also indicate a CPS or internal wiring failure.

### TORQUE

This LED indicates that excessive torque is present (over 105% of the drive rating).

### STALL

The drive is in a stall condition and stall protection has been activated.

### TEMP °F

Drive’s internal temperature is outside of rating.

### FB OPEN

External position Feedback signal is enabled, but not wired to an external load or the wiring has failed between the drive and the monitoring device.

### U VOLT

A low voltage condition inside the motor drive circuit is blocking drive movement.

## Pushbutton Controls

The five pushbuttons (pictured below) on the DCM customer interface panel are used for calibration. When pressing a pushbutton, pressure should be maintained until the “ACKNOWLEDGE” LED lights; this confirms receipt of the pushbutton command. See the Calibration section, beginning on page 48, for further explanation of the calibration procedures.

### CALIBRATE

A safety feature, this button must be pressed and held while pressing the pushbuttons described below to set the Position and Demand signal limits.

### CAUTION

**Pressing the following buttons may change calibration and cause the drive to reposition.**

### SET POS 100%

With the drive output shaft at the desired 100% position (this will correspond to a 100% Demand signal), press this button.

### SET POS 0%

With the drive output shaft at the desired 0% position (this will correspond to a 0% Demand signal), press this button.

### SET DEM 100%

With a 100% Demand input signal applied to the drive, press this button.

### SET DEM 0%

With a 0% Demand input signal applied to the drive, press this button.

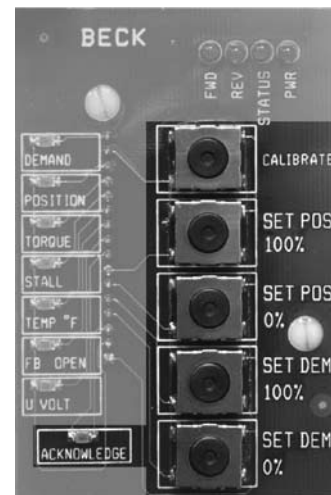
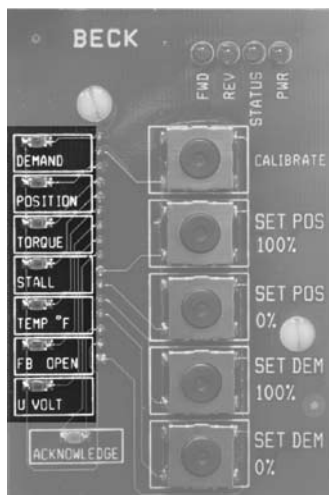

---

## **LOSS OF DEMAND INPUT SIGNAL (L.O.S.)**

When the Demand input signal drops to approximately 3.2 mA, the DCM considers the Demand input signal to be invalid. DCMs are typically configured to stop the drive during L.O.S. conditions, but may be factory configured to run the drive to a predetermined position. Under the L.O.S. condition, the “STATUS” and “DEMAND” LEDs will light, and contacts at terminals 12 & 13 will open. When the input signal is corrected, the drive will automatically resume normal operation.

## **POSITION: CONTACTLESS POSITION SENSOR (CPS)**

The CPS provides the DCM with a continuous feedback signal proportional to the position of the drive’s output shaft.

The position sensing function of the CPS is provided by a ferrite magnetic sensing element. An electronic circuit translates the signal from the ferrite magnetic sensor into a position signal used by the DCM to control the drive. The typical output voltage of the CPS ranges from 1.3 V at the CCW end of travel, to 3.7 V at the CW end of travel. This specific signal is not available for external connections. If the Position signal is outside the anticipated range, the “STATUS” and “POSITION” LEDs will light, and contacts at terminals 12 & 13 will open. When the Position signal is corrected, the drive will automatically resume normal operation.

## **TORQUE PROTECTION**

DCMs are equipped with a torque sensing module that will light the “STATUS” and “TORQUE” LEDs in the event excessive torque is detected, and contacts at terminals 12 & 13 will open. This alarm is normally set to activate when torque exceeds 105% of the drive rating. Torques above 115% of the drive rating will cause the DCM to stop trying to run in the direction of the high torque. When the over torque condition is corrected, the drive will automatically resume normal operation.

## **STALL PROTECTION AND ANNUNCIATION**

If the drive output shaft cannot reach a desired position within the configured time, the DCM shuts off power to the motor and the “STATUS” and “STALL” LEDs will light, and contacts at terminals 12 & 13 will open. The stall condition timing is factory configurable from 300 seconds to as low as 30 seconds and is set according to the specification at time of order (factory default setting is 300 seconds).

A sensed stall condition is cleared by either reversing the Demand input signal from the controller (such that the drive tries to run in the direction opposite the blocked direction) or switching the drive power off and on. When the stall condition is cleared, the drive will automatically resume normal operation.

## **TEMPERATURE**

DCMs are equipped with a temperature sensing circuit. The “STATUS” and “TEMP °F” LEDs will light when the drive’s ambient temperature exceeds the rating of the drive, and contacts at terminals 12 & 13 will open.

## **FEEDBACK SIGNAL**

A feedback sourcing module in the DCM provides a 4–20 mA analog output signal that represents the drive output shaft position in terms of 0–100% of full rotational travel. This signal can be remotely monitored or used by a controller or indicator. The “STATUS” and “FB OPEN” LEDs will light if the function is enabled and there is no current in the loop, and contacts at terminals 12 & 13 will open. The Feedback signal can be factory configured as disabled.

## **UNDER VOLTAGE**

The motor drive circuitry requires sufficient voltage to operate the motor properly. If this voltage is insufficient, the “STATUS” and “U VOLT” LEDs will light, and contacts at terminals 12 & 13 will open.

# DCM-L CALIBRATION DEMAND

---

DCM boards are designed to accept a 4–20 mA (or 1–5 V dc) analog Demand signal. Narrower spans within this range can also be accommodated for split range operation (see page 49). The input comes calibrated from the factory for the full range unless otherwise specified by the customer. It is not necessary to calibrate the Demand input when the drive is installed; however, it can be easily accomplished using the pushbutton controls and a signal source. Following this procedure is only necessary if the factory settings are inappropriate.

## Calibration Procedure

1. Remove the DCM cover (1/2" bolt heads).
2. Ensure the Handswitch is in the "STOP" position. This will prevent the drive from repositioning during this procedure.
3. Apply the desired 0% Demand input signal to the drive (e.g., 4 mA for 4–20 mA input).
4. Press and hold the "CALIBRATE" pushbutton on the DCM customer interface panel, then press the "SET DEM 0%" pushbutton until the "ACKNOWLEDGE" LED is lit.\*
5. Apply the desired 100% Demand input signal to the drive (e.g., 20 mA for 4–20 mA input).
6. Press and hold the "CALIBRATE" pushbutton on the DCM customer interface panel, then press the "SET DEM 100%" pushbutton until the "ACKNOWLEDGE" LED is lit.\*
7. Turn the Handswitch to the "AUTO" position.  
NOTE: The drive may reposition.
8. Run the drive through its full operating range to ensure proper response to the Demand input signal.
9. Replace the compartment covers and tighten the cover bolts to 10 lb-ft torque.

\* If the "ACKNOWLEDGE" LED does not light, but the "DEMAND" LED does light, the signal is out of acceptable range and was not accepted by the DCM. This is typically caused by trying to set 0% and 100% values too close together (i.e., less than 4 mA difference).



## SPLIT RANGE OPERATION

In applications where it is necessary (or preferable) to have more than one final control element controlling a single process, two to four Beck drives may be set up to respond to different portions of the Demand signal from the control system. The most common arrangement involves two drives; each operating on different halves of the input signal range. For example, if a 4–20 mA control signal is used, the first drive would move 100% of its stroke on a signal range of 4–12 mA, while the second operates on the 12–20 mA range.

To set up a split range operation, follow the steps listed below (see page 46 for location of pushbutton controls).

1. Remove the DCM cover (1/2" bolt heads).
2. Ensure the Handswitch is in the "STOP" position. This will prevent the drive from repositioning during this procedure.
3. Apply the desired 0% Demand input signal to the drive. (Following the example above, the minimum signal for the first drive would be 4 mA. The second drive's minimum signal would be 12 mA).
4. Press and hold the "CALIBRATE" pushbutton on the DCM customer interface panel, then press the "SET DEM 0%" pushbutton until the "ACKNOWLEDGE" LED is lit.\*
5. Apply the desired 100% Demand input signal to the drive. (Following the example above, the maximum signal for the first drive would be 12 mA. The second drive's maximum signal would be 20 mA).
6. Press and hold the "CALIBRATE" pushbutton on the DCM customer interface panel, then press the "SET DEM 100%" pushbutton until the "ACKNOWLEDGE" LED is lit.\*
7. Repeat this process for the remaining drives to be split-ranged.
8. Run the drive through its full operating range to ensure proper response to the Demand input signal.
9. Replace the DCM cover. Tighten the cover bolts to 10 lb-ft torque.

\* If the "ACKNOWLEDGE" LED does not light, but the "DEMAND" LED does light, the signal is out of acceptable range and was not accepted by the DCM. This is typically caused by trying to set 0% and 100% values too close together (i.e., less than 4 mA difference).

## SQUARE FUNCTION

Beck drives can be set up to position the output shaft proportionally to the square of the input signal (see table below). This function is factory configurable.

Input Signal (mA)	Standard Output (% of Span)	Square Function Actual Output Position (% of Span)
4.0	0	0
5.6	10	1
12.0	50	25
15.2	70	49
18.4	90	81
20.0	100	100

# DCM-L CALIBRATION POSITION

In order to correctly position the drive output shaft in response to the Demand input signal, the DCM receives a position signal from the drive's position sensor and compares this actual position to the Demand input. This process requires that the DCM interprets the position signal appropriately for the full range of desired travel. This procedure will calibrate the DCM to accept the position signal and interpret the appropriate 0–100% range.

## SHORT-STROKE OPERATION (Reducing Full Rotation)

Typically, it is best to use the full 100° rotation of the drive in response to the 0–100% Demand input signal—this allows full flexibility in arranging the drive's torque to be distributed for the best mechanical advantage relative to the driven load. However, in certain applications it may become necessary to reduce this response to less than 100°. In these applications, the DCM can be calibrated to accommodate reduced stroke. Full stroke rotation of 60 degrees or less is not recommended—contact the factory for details concerning your specific application. It is ideal to make the range as close to 100° as possible for the highest position resolution attainable with the CPS; if the driven element stroke rotation is less than 100°, a linkage can be used to allow the driven element to move the correct rotation while still allowing the drive to rotate 100°).

Reducing the full rotation is referred to as “short-stroking” the drive. This can be accomplished by using the DCM customer interface panel.

The illustration below represents a Beck drive requiring an 80° full stroke rotation. (Please note that the crank arm may be adjusted to any start angle orientation—see the “Crank Arm” section on page 13).

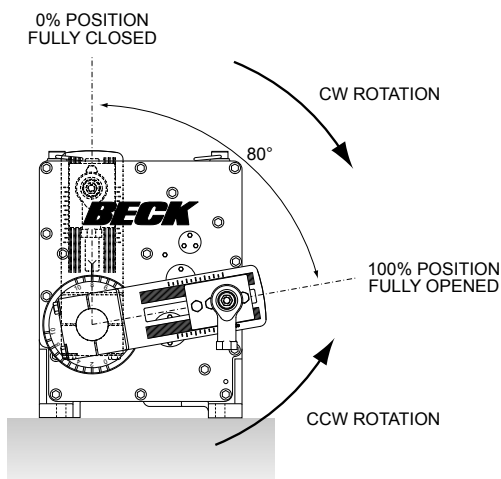

## Calibration Procedure

1. Remove the DCM cover (1/2" bolt heads).
2. Position the drive at the desired minimum position (i.e., the desired physical position of the drive's output shaft corresponding to the 0% Demand input signal).
3. Ensure the Handswitch is in the “STOP” position. This will prevent the drive from repositioning during this procedure.
4. Press and hold the “CALIBRATE” pushbutton on the DCM customer interface panel, then press the “SET POS 0%” pushbutton until the “ACKNOWLEDGE” LED is lit.\*
5. Position the drive at the desired maximum position (i.e., the desired physical position of the drive's output shaft corresponding to the 100% Demand input signal).
6. Ensure the Handswitch is in the “STOP” position. This will prevent the drive from repositioning during this procedure.
7. Press and hold the “CALIBRATE” pushbutton on the DCM customer interface panel, then press the “SET POS 100%” pushbutton until the “ACKNOWLEDGE” LED is lit.\*
8. Verify that the drive's 0% and 100% positions are correct. If not, repeat this procedure.
9. Replace the compartment cover and tighten the cover bolts to 10 lb-ft torque.

\* If the “ACKNOWLEDGE” LED does not light, but the “POSITION” LED does light, the signal is out of acceptable range and was not accepted by the DCM.

# DCM-L CALIBRATION *DIRECTION CHANGE* \_\_\_\_\_

## DIRECTION OF OUTPUT SHAFT ROTATION (CW vs. CCW)

Direction of output shaft rotation is determined by observing the end of the output shaft (see illustration on page 50). Direction of rotation is defined as the direction of output shaft rotation produced by an increasing Demand signal. Unless otherwise specified at the time of order, the output shaft is factory set to rotate clockwise in response to an increasing signal.

Changing the direction of output shaft rotation is easily accomplished using the DCM customer interface panel (see page 46 for location of pushbutton controls). Follow the steps below.

1. Remove the DCM cover (1/2" bolt heads).
2. Position the drive at the present 0% position.
3. Press and hold the "CALIBRATE" pushbutton on the DCM customer interface panel, then press the "SET POS 100%" pushbutton until the "ACKNOWLEDGE" LED is lit.\*

—OR—

2. Position the drive at the present 100% position.
3. Press and hold the "CALIBRATE" pushbutton on the DCM customer interface panel, then press the "SET POS 0%" pushbutton until the "ACKNOWLEDGE" LED is lit.\*
4. Ensure the drive operates as desired.
5. Replace the DCM cover and tighten the cover bolts to 10 lb-ft torque.
6. Adjust the travel index.

\* If the "ACKNOWLEDGE" LED does not light, but the "POSITION" LED does light, the signal is out of acceptable range and was not accepted by the DCM.

# MAINTENANCE

---

## ROUTINE

Beck drives require only a minimum of routine maintenance. A visual inspection is in order to verify that the connection to the final control element is intact and operating normally. If vibration is present, check the electrical terminal connections and other hardware for tightness.

## Fuses

Group 22 drives contain fuses to protect the wiring of the drive from over-current conditions. The fuses will not clear due to rated loads on the drive or due to high duty cycles. If the fuses clear, either improper voltage was connected to the drive or an internal failure occurred in the drive.

To find the reason for the fuse clearing, first check the applied voltage against the voltage rating of the drive. If the applied voltage appears correct, switch off all power, replace the cleared fuses, and restore power. If the drive works properly, there may have been a momentary problem with the applied voltage.

The 22-309 and 22-409 each have three fuses, and these fuses are contained on the DCM. Note that the DCM circuit boards are not powered through the fuses, and therefore the Control Board will stay active if the fuses are cleared.

The 22-809 has two sets of three fuses. One set of these fuses is electrically connected between the terminal block and the main three phase power transformer. If these fuses are cleared, the drive will have no functionality. These three fuses are located in the upper left area of the electronics compartment. To access these fuses, the DCM assembly must first be removed from the compartment.

The other set of three fuses is contained on the DCM. Note that the DCM circuit boards are not powered through the DCM fuses, and therefore the Control Board will stay active if the DCM fuses are cleared.

Refer to the Customer Replacement Kit table on page 53 to order replacement fuse kits.

## Transient Protection

Group 22 drives use several stages of protection against voltage transients. Circuit boards have various over-voltage protection devices, the DCM assembly that contains the circuit boards has varistor over-voltage protection components on the power wiring, and the customer terminal block has varistor over-voltage protection components on the line power terminals. The DCM is not intended to be serviced by the customer. The varistors on the customer terminal block are intended to be replaced by the customer if they are damaged.

Refer to the Customer Replacement Kit table on page 53 to order replacement surge suppressor kits.

## Lubrication

The Group 22 control drive has a grease filled gear housing, so periodic lubrication is not required. However, to extend the life of the linkage rod ends, they should be lubricated periodically.

## COMPONENT REPLACEMENT

The following table lists the components of the Group 22 control drive that are field replaceable. Each of these components is available as a customer replacement kit which includes the component(s), necessary hardware and detailed instructions.

## HOW TO ORDER SPARE PARTS

Any customer replacement kit may be purchased for spare parts. Contact your Beck Sales Engineer for recommended replacement parts particular to your application. Parts may be ordered by mail, telephone, fax or e-mail, with the confirming order sent to the factory (see back cover).

### CUSTOMER REPLACEMENT KITS

CUSTOMER KIT	PART NUMBER	APPLICABLE MODELS		
		22-309	22-409	22-809
Motor Replacement	12-8061-01	●	●	
Motor w/Handcrank Assembly Replacement	12-8061-20			●
Handwheel / Dampener	12-8061-02	●	●	
Handwheel / Dampener	12-8061-22			●
Handcrank Assembly	12-8061-27			●
Self-Locking Mechanism Rebuild (20-2205-10,-12 motor)	12-8061-69	●	●	
Self-Locking Mechanism Rebuild	12-8061-23			●
DCM-H (single-phase)	12-8061-04	●		
DCM-H (three-phase)	12-8061-24		●	●
DCM-L (single-phase)	12-8061-15	●		
DCM-L (three-phase)	12-8061-25		●	●
Control End Assembly	12-8061-05	●	●	●
CPS-4 Switch Assembly	12-8061-06	●	●	●
CPS-4 P.C. Board	12-8061-07	●	●	●
CPS-4 Coupling	12-8061-08	●	●	●
Gasket Set	12-8061-09	●	●	
Gasket Set	12-8061-29			●
Service Screw Set	12-8061-10	●	●	
Service Screw Set	12-8061-30			●
Mounting Shim Set	12-8061-11	●	●	●
Handswitch	12-8061-12	●	●	●
Capacitor (single-phase)	12-8061-14	●		
Transient Protector	12-8061-40	●		
Transient Protector (single-phase, 130V)	12-8061-44	●		
Transient Protector (single-phase, 250V)	12-8061-42	●		
Transient Protector (three-phase, 230V)	12-8061-43		●	
Transient Protector (three-phase, 230V)	12-8061-45			●
Transient Protector (three-phase, 250V)	12-8061-46			●
Transient Protector (three-phase, 385V)	12-8061-54			●
Transient Protector (three-phase, 420V)	12-8061-55			●
Transient Protector (three-phase, 480V)	12-8061-47			●
Transient Protector (three-phase, 575V)	12-8061-48			●
Fuse, 8A-DCM	12-8061-53	●	●	
Fuse, 4A-Input, 8A-DCM (240V Drive only)	12-8061-50	●		
Fuse, 10A-Input, 8A-DCM	12-8061-51			●
Fuse, 4A-Input, 8A-DCM	12-8061-52			●

# APPENDIX SERIAL COMMANDS

## Communications

The Beck Digital Control Module (DCM) is equipped with a serial interface which allows for direct communication with a computer. Using a communication cord, connect the DCM to the computer using the DCM's RS-232 (J20) connector (see illustration on this page) and the computer's COM port. Ensure that the COM port on the computer is active, and that the cord is plugged into the proper COM port if more than one is present (e.g., COM1, COM2, etc.). Note that a plug end adapter may be necessary for connection to the computer's COM port.

Once connected, communication can be established between the DCM and the computer using a terminal emulation program, such as HyperTerminal. This method of communication will allow for configuration, calibration and verification of drive DCM settings without the use of custom software applications.

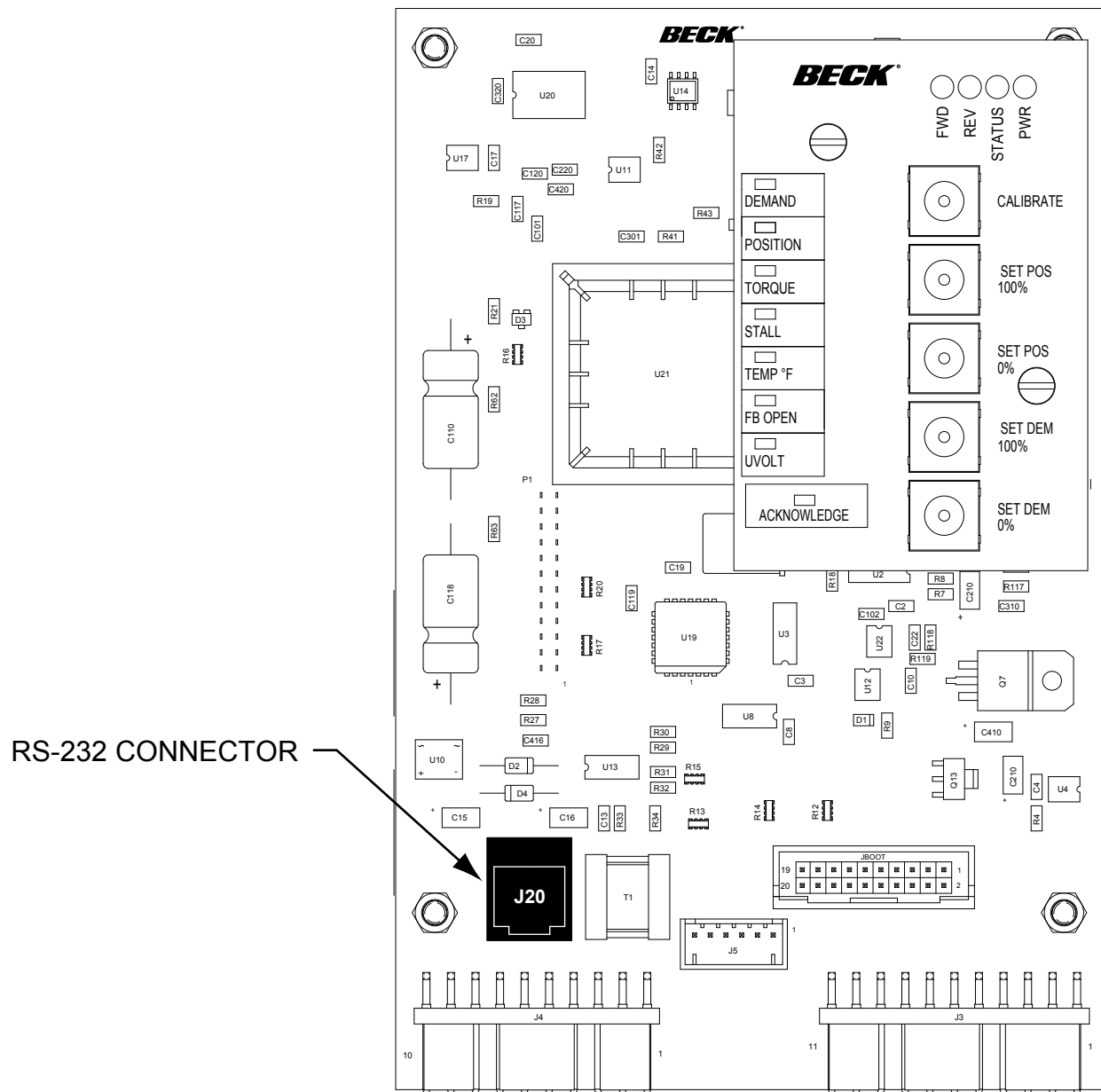

Location of RS-232 Connector on the DCM-L Board  
(Location is the same on the DCM-H Board)

## HyperTerminal Software

HyperTerminal is the standard ASCII terminal emulation software provided with Microsoft Windows. If using HyperTerminal, the following instructions will assist in setup. Note that some variation to these instructions may be necessary depending on the version of HyperTerminal being used.

Once the computer has been plugged into the DCM, access HyperTerminal by clicking first on "Start", then "Programs", then "Accessories", then "Communications", then "HyperTerminal".

Double-click on the "Hypertrm.exe" icon to start the program. Once HyperTerminal is running, it is necessary to set up a file with the proper settings to communicate with the DCM. Proceed as follows:

1. If prompted to install a modem, answer "no". Proceed to enter a name (e.g., "DCM") and select an icon (any will suffice) in the "Connection Description" box. Click the "OK" button.
2. The "Connect to" box should open next. At the bottom of the box, set the "Connect using" selection to the computer COM port that has been connected to the DCM. Click the "OK" button.
3. The COM port properties box should open next. This is where the communication settings are established. The correct settings are:
  - a. Bits per second = "1200"
  - b. Data bits = "8"
  - c. Parity = "none"
  - d. Stop bits = "1"
  - e. Flow control = "none"
4. With the appropriate settings entered from Step 3, above, click "OK". Communications should now be enabled.
5. Press the "Enter" key twice. "Ok" should be displayed indicating that HyperTerminal is communicating with the DCM.

## Commands and Arguments

Commands can be used for a variety of functions including changing the operating configuration of the drive, verifying operation settings, calibration and accessing diagnostic information. There are essentially four different types of commands:

1. **Dual-purpose commands.** These commands can be used to either modify drive configuration settings or display the settings already set in the drive. In order to set or make a change to the settings, the command requires an argument (*n*). If the command is used for display purposes only, the argument is omitted. Examples of these commands include "deadband" and "demlos".
2. **Display only commands.** These commands are used to display diagnostic or operating information like present signal values. No arguments are required. Examples include the "stat" command and the "signals" command.
3. **Set only commands.** These commands serve only to make a parameter change. Typically, they apply to the drive calibration. This type of command requires an argument, but unlike dual-purpose commands, they return an error message when entered without an argument. Examples include the "dem0pctma" and "posisp" commands.
4. **Execute action commands.** These commands serve to reset, enable or disable features. Entering these commands produces an immediate action. Examples include the "restoremodes" and "torqenable" command.

The available commands are listed on page 56 and each is described in more detail on pages 57 through 61. The command description explains the use or uses of the command, while the argument column describes the applicable arguments for those commands that require them. In the command tables, arguments are denoted as *n*. Note that the commands described as "sets and/or displays" signify dual purpose commands that can be used with or without an argument for setting or verifying configuration settings.

# APPENDIX SERIAL COMMANDS

---

## BCP COMMANDS

The following is a list of serial commands available through the RS-232 interface.

### General Configuration Commands (page 57)

alarmout  
alarmoutmask  
configformodel  
drvdir  
drvmodel  
drvtiming  
limitalarm  
opmode  
restoremodes  
sernum  
stallprot  
stalltime  
stepsize

### HART® Configuration Commands (page 58)

harttype  
polladdr

### Demand Characterizer Commands (page 58)

charclear  
charlist  
charset  
demfunc

### Demand Signal Commands (page 59)

dem0pctma  
dem100pctma  
trimdem4mA  
trimdem20mA  
demlos  
demlosgtp

### Output Shaft Position Sensing Commands (page 60)

cpsrotation  
cpsvat0pct  
posisd  
posisp  
travel  
travelmax

### Feedback Signal Commands (page 61)

fdbk0pctma  
fdbk100pctma  
fdbkfunc  
trimfdbk4mA  
trimfdbk20mA  
iomode

### Torque Sensing Commands (page 62)

ovtstop  
ovtstoplevel  
torq  
torq0k  
torq0pct  
torq100pct  
torqalarm  
torqconst  
torqenable  
torqprof

### Diagnostic and Information Commands (page 63)

codes  
reset  
signals  
stat  
temperature  
uninstall



## General Configuration Commands

Command	Description	Argument n and Information
<b>alarmout n</b>	Sets/displays the polarity of the alarm output solid state relay.	n = "0": Open on Alarm n = "1": Closed on Alarm
<b>alarmoutmask n</b>	Sets/displays the hexadecimal mask of which alarms cause the alarm output relay to open or close.	n = bit-wise OR-ed, 32-bit hexadecimal value, high bits indicate alarm will change output relay. Default value = 0xFFFFFFFF, which means all alarms cause the relay to change state.
<b>configformodel n</b>	Sets the DCM-2 position sensing voltage range to the values appropriate for the actuator model and CPS output signal.	n must equal "1" for the command to execute.
<b>drvdir n</b>	Sets/displays the output shaft direction resulting from an increasing Demand signal.	n = "0": CW rotation for increasing. n = "1": CW rotation for increasing.
<b>drvmodel n</b>	Sets/displays the model no. of the drive in which the DCM is installed.	n = "12" (model 22-309) n = "13" (model 22-409) n = "14" (model 22-809)
<b>drvtiming n</b>	Sets/displays the timing of the drive.	n = seconds per 100° of travel. The min. value is "15" ("30" for model 22-309) and the max. value is "300".
<b>limitalarm n</b>	Sets/displays a modifier to the Stop/Limit alarm.	n = "0": "mute" corresponds to "Accept" for FF and HART. n = "1": "always" corresponds to "Alert" for FF and HART.
<b>opmode n</b>	Sets/displays the mode that controls the Demand signal source. This mode selects analog or digital control.	n = "0": "follow" is analog Demand. n = "1": "hold" is digital Demand. n = "2": run CW. n = "3": run CCW. n = "4": stay. n = "5": stop.
<b>restoremodes n</b>	The DCM-2 configuration returns to the original factory settings.	n must equal "1" for the command to execute.
<b>sernum n</b>	Sets serial no. of the actuator. Model no. info. used by the DCM-2 is derived from the serial no.	n = serial number.
<b>stallprot n</b>	Sets/displays the enabled/disabled value for Stall protection.	n = "0": disabled. n = "1": enabled.
<b>stalltime n</b>	Sets/displays the time allowed for the actuator to reach its Demand target.	n = time in seconds. Time to stall is configurable from 30 to 450 seconds. The default value is 300 seconds.
<b>stepsize n%</b>	Sets/displays the size (in %) of one incremental movement of the output shaft. Whether setting or displaying, include the % symbol. Without the % symbol, the unit of measure is degrees.	n = step size in %. The minimum value that can be entered is "0.10"; which is also the standard value. The maximum value is "2.50". Without the % symbol, the unit of measure is degrees.

# APPENDIX SERIAL COMMANDS

## HART® Configuration Commands

Command	Description	Argument n and Information
<b>harttype n</b>	Sets and/or displays the DCM-2 HART device type. DD number 239 is the proper DD. The others are for temporary use with older DD's if the new DD is not available. If the DCM-2 is configured for Foundation Fieldbus, the device type must be set to 239.	n = "1": ESR-D n = "10": BECK-DCM n = "239": BECK-MK2
<b>polladdr n</b>	Sets and/or displays the polling address used by the HART master to find individual devices if the HART bus has more than one device. Unless multiple HART devices are connected in parallel on a single bus, the polling address should be set to 0. If the DCM-2 is configured for Foundation Fieldbus, the polling address must be set to 0.	n = the polling address, a value between 0 and 15.

## Demand Characterizer Commands

Command	Description	Argument n and Information
<b>charclear n</b>	Sets the status of a characterizer node to "unused." Any nodes with higher node numbers are also set to unused.	n = node number to make unused
<b>charlist n</b>	Displays the X-values and Y-values in percent of the nodes of the characterizer curve. The argument is which node to use to begin the display. This node number does not change which nodes are active.	n = node number to begin display OR n = "all": display all values
<b>charset n</b>	Sets the X-values and Y-values of a specific node of the characterizer curve. Requires a set of three arguments separated with commas.	n1, n2, n2 = node number to modify, X-value in percent, Y-value in percent.
<b>demfunc n</b>	Sets and/or displays the Demand signal characterization function.	n = "0": Linear n = "1": Square Root n = "4": Special Curve n = "5": Square

## Demand Signal Commands

Command	Description	Argument n and Information
<b>dem0pctma</b> n Used with analog Demand signals.	Sets and/or displays the Demand signal value that corresponds to 0%.	n = the Demand signal as a decimal in mA. The minimum acceptable value is 0.50. The maximum acceptable value is 100% Demand less 4.00. For example, if the 100% Demand signal is 20.00, then the 0% Demand signal must be 16.00 or less.
<b>dem100pctma</b> n Used with analog Demand signals.	Sets and/or displays the Demand signal value that corresponds to 100%.	n = the Demand signal as a decimal in milliamps. The minimum acceptable value is the 0% Demand plus 4.00. For example, if the 0% Demand signal is 4.00, then the 100% Demand signal must be 8.00 or greater. The maximum acceptable value is 21.00.
<b>trimdem4mA</b> 4 Used with analog Demand signals.	Trims the Demand analog-to-digital sensing circuit to be accurate at 4 mA. This command should only be used when the Demand signal at the actuator is exactly 4 mA. Trim is factory set. Recalibration should not be necessary.	Trim can only be performed at 4 mA.
<b>trimdem20mA</b> 20 Used with analog Demand signals.	Trims the Demand analog-to-digital sensing circuit to be accurate at 20 mA. This command should only be used when the Demand signal at the actuator is exactly 20 mA. Trim is factory set. Recalibration should not be necessary.	Trim can only be performed at 20 mA.
<b>demlos</b> n Used with analog Demand signals.	Sets and/or displays the Demand signal threshold below which the DCM-2 recognizes that the signal is lost. The threshold is entered as a value in mA. This command also sets and/or displays the action initiated by the drive during LOS (Loss Of Signal). LOS action options are "sip" (stay in place) or "gtp" (go to position). Demlos always reports both settings, but only sets one argument at a time. Demlos must be used twice to set the threshold and action.	n = the Demand signal in mA below which LOS occurs. A typical value for a 4 mA–20 mA system is 3.20. — OR — n = "sip", "gtp" or "pat". Mode "pat" acts the same as Stay in Place, but suppresses the alarm. This is used in some pulsed applications.
<b>demlosgtp</b> n Used with analog Demand signals.	Sets and/or displays the position to which the drive will run upon loss of the Demand signal (LOS). This command has no effect if the drive is set to "sip" (stay in place).	n = the desired position of the drive expressed as a percentage of drive travel. For example, if the desired go-to-position is 50%, then n = 50.00.

# APPENDIX SERIAL COMMANDS

## Output Shaft Position Sensing Commands

Command	Description	Argument n and Information
<b>cpsrotation n</b>	Sets and/or displays the DCM-2 parameter for the expected output shaft direction for an increase in CPS signal. This should be set to CW for increasing signal for all non-custom applications.	n = 0: CW increasing n = 1: CCW increasing
<b>cpsvat0pct n</b>	Sets and/or displays the DCM-2 voltage setting used to determine 0% signal from the CPS. The CPS calibration is defined by the actuator model. Refer to CPS Calibration.	n = the desired length of travel in degrees. This value cannot exceed the maximum output shaft rotation of the actuator.
<b>posisd n</b>	Sets CPS Zero% through an alternate method. Use this command if the exact CPS signal voltage at 0% shaft position is not known. The output shaft can be positioned to 0%, then execute this command with an argument of 0. CPS Zero% will be adjusted to match the CPS signal voltage at that point. Travel does not change, so the 100% point will change.	n = the present drive position in angular degrees.
<b>posisp n</b>	Sets Travel through an alternate method. Use this command if an exact angular Travel is not known. The output shaft can be positioned to 100%, then execute this command with an argument of 100. Travel will be adjusted to the correct number of degrees for this to be 100%. The 0% point does not change, and therefore the 0% point should be set first. Refer to OUTPUT SHAFT 0% POSITION for more information on the 0% point.	n = the present position in angular degrees.
<b>travel n</b>	Sets and/or displays the number of degrees that represents 100% travel. This command does not shift the 0% position. When increasing travel from a reduced travel setting, the 0% position might have to be changed first in order to keep the travel with the acceptable end points. The end points are defined by the CPS voltage range.	n = the desired length of travel in degrees. This value cannot exceed the maximum output shaft rotation of the actuator.
<b>travelmax n</b>	Displays the maximum travel of the drive.	n = the maximum drive travel in degrees.

## Feedback Signal Commands

Command	Description	Argument n and Information
<b>fdbk0pctma n</b> Used with analog Feedback signals.	Sets and/or displays the mA value of the Feedback signal that represents the 0% output shaft position.	n = the desired Feedback signal in mA at 0% output shaft position . The minimum value is 3.00 and the maximum value is at least 4.00 less than the Feedback signal value for the 100% output shaft position.
<b>fdbk100pctma n</b> Used with analog Feedback signals.	Sets and/or displays the mA value of the Feedback signal that represents the 100% output shaft position.	n = the desired Feedback signal in mA at 100% output shaft position. The minimum value must be at least 4.00 greater than the Feedback signal value for the 0% output shaft position. The maximum value is 21.00.
<b>fdbkfunc n</b> Used with analog Feedback signals.	Sets and/or displays the curve used to calculate the Feedback signal.	n = "0": Linear (curve disabled) n = "1": Inverse Demand (curve enabled)
<b>trimfdbk4mA n</b> Used with analog Feedback signals.	Trims the Feedback signal at 4 mA. The Feedback sourcing circuit is factory calibrated and normally does not require recalibration.	n = the present Feedback signal from the DCM-2 as measured in mA.
<b>trimfdbk20mA n</b> Used with analog Feedback signals.	Trims the Feedback signal at 20 mA. The Feedback sourcing circuit is factory calibrated and normally does not require recalibration.	n = the present Feedback signal from the DCM-2 as measured in mA.
<b>iomode n</b> Used with analog Feedback signals.	Sets and/or displays the function of a DCM-2 connector pin. The DCM-2 pin that is used to source the Feedback signal can instead be used to power an output shaft position-sensing potentiometer on models of Beck actuator that do not use the CPS. If the pin use parameter is not set to Feedback, the Feedback circuit is disabled. If the pin use parameter is set to Pot, 5 V dc is output from this pin to power the potentiometer. Setting the parameter to None disables the Feedback and the potentiometer supply.	n = "0": None n = "1": Feedback enabled n = "2": Potentiometer power enabled

# APPENDIX SERIAL COMMANDS

## Torque Sensing Commands

Command	Description	Argument n and Information
<b>ovtstop</b> n	Sets and/or displays whether motor power will be removed during severe output shaft over-torque conditions. Torque sensing must be installed and enabled for this to be effective.	n = "0": disabled n = "1": enabled
<b>ovtstoplevel</b> n	Sets and/or displays the torque magnitude associated with severe output shaft over-torque conditions.	n = allowable torque magnitude without stopping motor, in percent of actuator rating.
<b>torq</b>	Displays the torque on the output shaft measurement as a percentage of actuator rating. Also displays related values such as torq0k and torqconst.	No argument.
<b>torq0k</b> n	Sets and/or displays the value of DCM-2 internal measurement corresponding to 0% torque on the output shaft.	n = the zero torque value in counts.
<b>torq0pct</b> n	Sets torq0k. This is an alternate method for setting torq0k, and is useful when the correct torq0k value is not already known. To use this command, remove all load from the output shaft, then execute torq0pct with argument = 0 to let the DCM-2 know that the torque sensing should be reading 0%.	n = 0
<b>torq100pct</b> n	Sets torqconst. This is an alternate method for setting torqconst, and is useful when the correct torqconst value is not known, but the exact output torque is known. To use this command, load the output shaft with an exact load, preferably 100%. Then execute torq100pct to let the DCM-2 know what the torque sensing should be reading.	n = the exact output shaft torque as a percent of rated load of the actuator.
<b>torqalarm</b> n	Sets and/or displays the torque magnitude associated with the first level of alarm.	n = allowable torque magnitude without alarm, in percent of actuator rating.
<b>torqconst</b> n	Sets and/or displays the value of DCM-2 internal measurement corresponding to the torque span (the measurement at 100% minus the measurement at 0%).	n = the torque span value in counts.
<b>torqenable</b> n	Sets and/or displays the enabled or disabled status of torque sensing.	n = "0": disabled n = "1": enabled
<b>torqprof</b>	Displays a table of three column: 1. Maximum travel divided into 10 segments 2. peak torque measured in each segment with motor running CW 3. peak torque measured in each segment with motor running CCW	No argument.

## Diagnostics and Information Commands

Command	Description	Argument n and Information
<b>codes</b>	Displays the present status of motor power inhibitors, pushbutton status, LED status, the process variable inside/outside limits status, analog signal measurement status, discrete input status, and alarm status. All information is in Bit-wise ORed hexadecimal notation. Each status word is decoded onscreen for convenience.	No argument.
<b>reset n</b>	The microcomputer performs the same reset sequence as when power is removed and reapplied.	n must equal "1" for the command to execute.
<b>signals n</b>	Displays the present DCM-2 readings of four signals: Position signal from CPS Demand (analog systems) Feedback (analog systems) Torque.	If no argument, the signal readings are returned. n = "all": an extended set of data is returned.
<b>stat</b>	Displays information on the status of the actuator, including: Time / Date Demand Position Error ( Demand minus Position) Step size Dead band Motor Status Motor Run Time Line Frequency Motor Starts Motor Reversals/Stalls Number of Over-Torque conditions Positive & Negative Peak Torque (%) CW and CCW Inhibitor Status Alarms	No argument.
<b>temperature n</b>	Displays three values describing the ambient temperature in the actuator. Low extreme, present, high extreme. Can also change the temperature units.	If no argument, the temperatures are displayed in the active units. n = "F": change units to Fahrenheit n = "C": change units to Celsius
<b>un stall</b>	Resets the Stall Protection alarm to restore power to the motor. If the motor is still physically stalled, the Stall Protection alarm will recur.	No argument.

# MODEL 275 HANDHELD COMMUNICATOR MENU STRUCTURE AS DISPLAYED

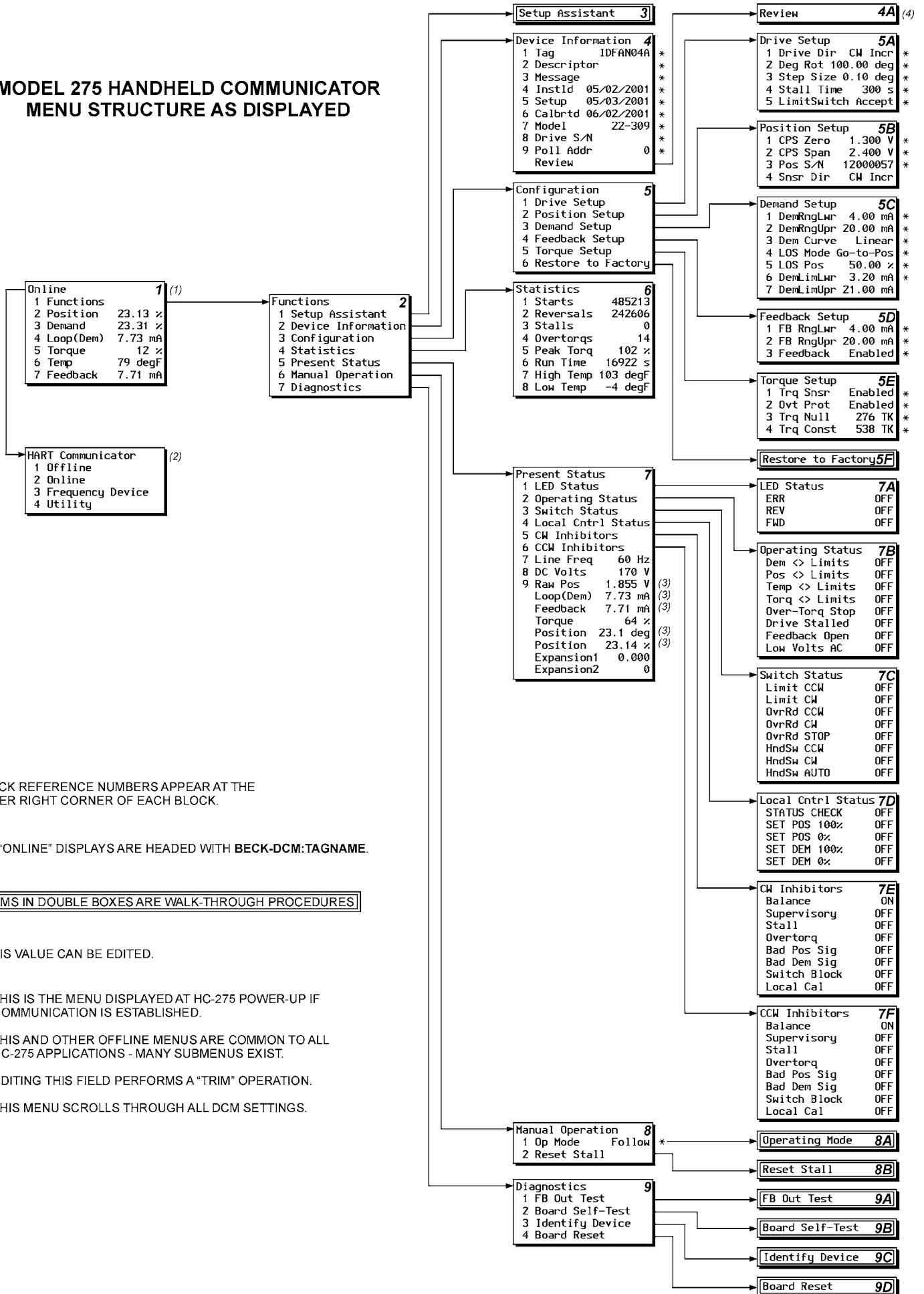

BLOCK REFERENCE NUMBERS APPEAR AT THE UPPER RIGHT CORNER OF EACH BLOCK.

ALL "ONLINE" DISPLAYS ARE HEADED WITH **BECK-DCM:TAGNAME**.

ITEMS IN DOUBLE BOXES ARE WALK-THROUGH PROCEDURES

\* THIS VALUE CAN BE EDITED.

(1) THIS IS THE MENU DISPLAYED AT HC-275 POWER-UP IF COMMUNICATION IS ESTABLISHED.

(2) THIS AND OTHER OFFLINE MENUS ARE COMMON TO ALL HC-275 APPLICATIONS - MANY SUBMENUS EXIST.

(3) EDITING THIS FIELD PERFORMS A "TRIM" OPERATION.

(4) THIS MENU SCROLLS THROUGH ALL DCM SETTINGS.



## ***NOTES***

## **NOTES**

# SERVICES

---

## PRODUCT DEMONSTRATIONS

Each of Beck's Sales Engineers has access to a complete set of drive models so that he can demonstrate virtually any of their features at your location. In order to arrange to see a Beck drive in your plant or office, contact Beck's Sales Department.

## SITE SURVEYS

Beck Sales Engineers are available to discuss your process control requirements. Often a visit to your location is the best way to gain a thorough understanding of your needs, in order to meet them most accurately and completely.

Mounting hardware, torque requirements, linkage, control signal information, and optional equipment can be analyzed most effectively at the work site. Beck's analysis at the job site can help ensure that specifications are accurate, especially in the case of complex applications.

## APPLICATION REVIEWS

By sharing your needs with a Beck Sales Engineer you can take advantage of the best application advice for the type of control you need.

This review will yield a better understanding of the versatility of Beck drives for your installations, as well as complete details on options and accessories to make the process as effective as possible.

## SPECIFICATION WRITING

Beck provides specification writing assistance in order to help you specify and order the right drives for your applications. Beck Sales Engineers will work with you to make it easier for you to obtain the proper equipment and give you confidence that no details are overlooked.

## HOW TO OBTAIN SERVICE

Factory repair of drives or subassemblies is available for both normal and emergency service. To assure prompt processing, contact the factory to receive a Returned Material Authorization (RMA) number. If a repair estimation is desired, please send the name and phone number of your contact for service authorization. It is helpful to include a description of the work desired with the shipment or, in the event of a problem, the malfunction being experienced.

## THREE YEAR LIMITED WARRANTY STATEMENT

---

Harold Beck & Sons, Inc. (Beck) warrants that our equipment shall conform to Beck's standard specifications. Beck warrants said equipment to be free from defects in materials and workmanship. This warranty applies to normal recommended use and service for three years from the date on which the equipment is shipped. Improper installation, misuse, improper maintenance, and normal wear and tear are not covered.

The Buyer must notify Beck of any warranty issues within 37 months of original shipment date and return the goods in question, at Buyer's expense, to Beck for evaluation. If the product fails to conform to the warranty, Beck's sole obligation and the Buyer's exclusive remedy will be: 1) the repair or replacement, without charge, at Beck's factory, of any defective equipment covered by this warranty, or 2) at Beck's option, a full refund of the purchase price. In no event will Beck's liability exceed the contract price for the goods claimed to be defective.

THIS WARRANTY IS EXPRESSLY IN LIEU OF ANY OTHER EXPRESS OR IMPLIED WARRANTY, INCLUDING IMPLIED WARRANTIES OF MERCHANTABILITY AND FITNESS FOR A PARTICULAR PURPOSE, AND ALL OTHER OBLIGATIONS OR LIABILITIES OF BECK. In no case shall Beck be liable for any special, incidental or consequential damages based upon breach of warranty, breach of contract, negligence, strict tort, or any other legal theory. Such damages include, but are not limited to, loss of profits, loss of revenue, loss of use of the equipment or any associated equipment, cost of capital, cost of any substitute equipment, facilities or service, downtime, the claims of third parties including customers and injury to property.

Buyer acknowledges its responsibilities under OSHA, related laws and regulations, and other safety laws, regulations, standards, practices or recommendations that are principally directed to the use of equipment in its operating environment. Buyer acknowledges that the conditions under which the equipment will be used, its use or combination with, or proximity to, other equipment, and other circumstances of the operation of such equipment are matters beyond Beck's control. **Buyer hereby agrees to indemnify Beck against all claims, damages, costs or liabilities (including but not limited to, attorney's fees and other legal expenses), whether on account of negligence or otherwise, except those claims based solely upon the negligence of Beck and those claims asserted by Beck's employees which arise out of or result from the operation or use of the equipment by Beck's employees.**

---

© Copyright 2008 by Harold Beck & Sons, Inc.

Beck Control Drives are covered by the following patents: 3,667,578; 4,690,168; 6,563,412 B2; and 6,639,375 B2 with other patents pending.

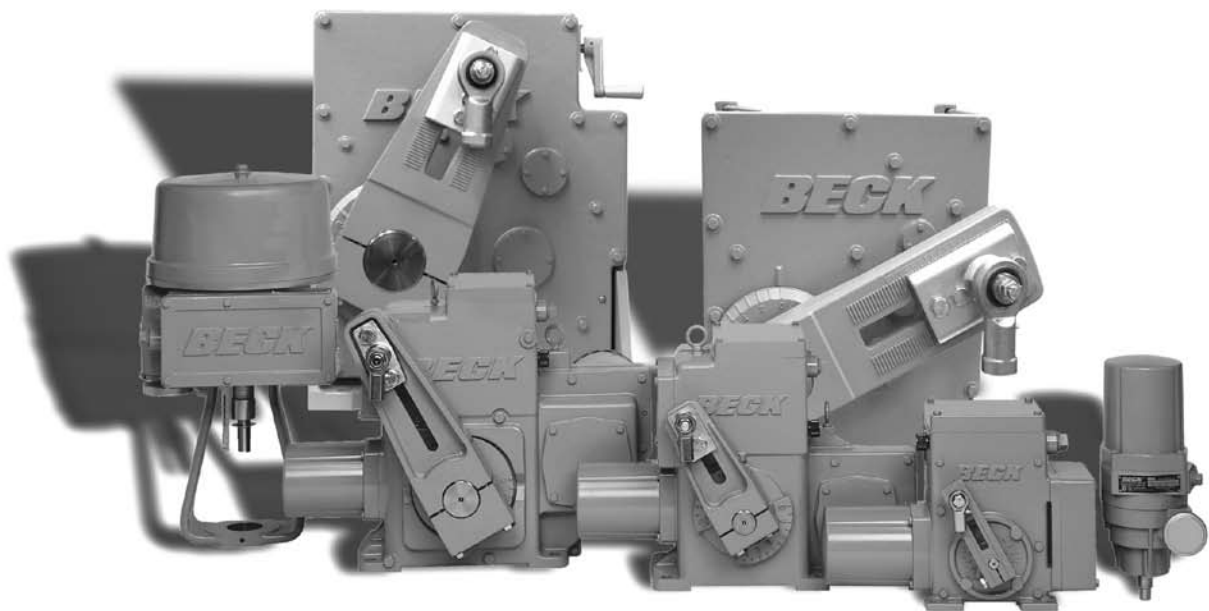

**BECK**<sup>®</sup> **HAROLD BECK & SONS, INC.**

11 TERRY DRIVE • NEWTOWN, PENNSYLVANIA 18940 • USA  
PHONE: 215-968-4600 • FAX: 215-860-6383 • [www.haroldbeck.com](http://www.haroldbeck.com)

09/08