



SLM REBUILD INSTRUCTIONS

SLM REBUILD KIT (P/N 12-8061-23) FOR MOTOR ASSY(P/N 20-2205-30)

PURPOSE

The purpose of these instructions is to provide a step-by-step method for rebuilding the Self-Locking Mechanism (SLM) of the 22-809 motor utilizing rebuild kit no. 12-8061-23.

NOTE: Do not disassemble the motor or Handcrank beyond what is indicated in these instructions, as they have no other user serviceable parts. Further disassembly will result in demagnetization of the motor and loss of the required torque.

REQUIRED TOOLS

- Hoist to lift 220 lb (100 kg) motor
- 3/4" socket
- 3/16" hex driver
- 5/32" hex driver
- Loctite® Threadlocker 242 or equivalent
- Mobilith SHC 007 or equivalent grease
- Feeler gauge .010" (.25 mm)
- Torque wrenches (appropriate for 150 lb-in (17 N•m) and 50 lb-ft (68 N•m))
- Scotch™ 847 gasket adhesive or equivalent
- Flat-tipped screwdriver



WARNING
ELECTRICAL SHOCK HAZARD!
Disconnect power before proceeding.

PROCEDURE

Remove the motor:



CAUTION
Secure the load prior to removing the motor. The actuator **WILL NOT** support the load once the motor is removed.

1. Remove power from the actuator.
2. Remove and retain the cap plugs from the holes (2) located in the top of the motor. Install the eyebolts and spacer (provided) in the holes as shown in Figure 1.

3. Support the motor's weight by suspending it from a suitable hoist using both eyebolts. **Motor weight: 220 lbs (100 kg).**



CAUTION
To prevent damage to the rotor shaft, use the eyebolts supplied in the kit to support the weight of the motor while pulling it away from the actuator. Use the eyebolts to lift the motor only—do not lift the entire actuator with the eyebolts.

4. Remove one of the top 1/2-13 motor mounting bolts from the motor (see Figure 1), then remove the bottom opposite 1/2-13 bolt.
5. Using a flat-tipped screwdriver, install the alignment studs (provided) where the bolts were removed in step 4. This will aid in motor removal and mounting.
6. Remove the two remaining 1/2-13 motor mounting bolts and pull the motor straight out from the actuator body.

To disassemble and rebuild the SLM:

NOTE: Refer to Figure 2 for SLM part names and their location.

7. Stand the motor on end with the pinion up.
8. Loosen the 1/4-28 socket cap screw in the bearing clamp nut and unthread the nut from the end of the rotor shaft.
9. Remove the thrust bearing, pinion, spring, teflon and steel spacers, steel balls (12) and locking disc from the rotor shaft. Inspect all parts and replace if necessary.
10. Remove the six 10-32 x 1 3/4" socket cap screws and lift the drive collar from the motor.
11. Lightly sand the friction material, then clean the friction material and driving disc flange with alcohol and a lint-free cloth.

12. Lightly coat the threads of the new 10-32 x 1 3/4 socket cap screws with Loctite™ Threadlocker 242 (or equivalent).
13. Install the new drive collar and tighten the screws to 76 lb-in torque.
14. Brush a thin film of Mobilith SHC 007 grease (or equivalent) into the ball detents (24 places). Grease the thrust bearing and the ID of the locking disc. Ensure the friction material and driving disc flange are not contaminated with grease.
15. Place (6) steel balls in the conical drive collar detents and install the locking disc, seating the conical locking disc detents properly over the steel balls.
16. Place the remaining (6) steel balls in the conical locking disc detents. Install the teflon spacer, then the steel spacer. Install the spring, then place the pinion over the steel balls and the spring.
17. Place the thrust bearing on the shaft with the larger ID facing the pinion.
18. With the shoulder side towards the bearing, screw the clamp nut onto the shaft while compressing the spring as far as the locking disc and pinion allow. If the pinion can rotate, the teflon spacer is pinched between the pinion and locking disc.
19. Adjust the SLM gap by backing off the clamp nut. Holding down on the pinion, the gap should be approximately 0.010 inch (.25 mm). Back the nut off fifty degrees or use a feeler gauge. Tighten the clamp nut 1/4-28 socket cap screw to 150 lb-in (17 N•m) torque.
20. Examine the Handcrank gasket for damage (cuts, tears, missing sections, etc.). If the gasket is damaged, follow steps 21–23 below to replace the gasket; if the gasket does not need replacing, skip to step 24.
21. Clean the mating face of the actuator body to remove any remaining gasket material and adhesive. Ensure that the mating surface is free of defects such as dents or gouges.
22. Apply a thin film of gasket adhesive (Scotch 847™ gasket adhesive or equivalent) to the body's mating face.
23. Press the new gasket (supplied) into place. Ensure the gasket is flat against the mating surface (no bumps, bunching of the material, etc.). Allow time for the adhesive to set before continuing.
24. Using both eyebolts and the spacer for lifting, reinstall the motor by aligning the motor mounting bolt holes with the corresponding installed alignment studs. Turn the Handwheel as necessary while mounting the motor to allow the pinion to slide into and mesh with the gearing.
25. Install two of the 1/2-13 motor mounting bolts into the assembly opposite the alignment studs and hand tighten to hold the motor in place.
26. Remove the two alignment studs and install the remaining two 1/2-13 motor mounting bolts and torque all four mounting bolts to 50 lb-ft (68 N•m) in a cross-wise pattern.
27. Remove the eyebolts and spacer. Reinstall the cap plugs.
28. Apply power and use the Handswitch to observe the motor and actuator for proper operation.

Table 1: Motor Replacement Kit

Description	Kit Number
Eyebolt 5/16-18 x 1" (2)	30-0306-05
Bearing Clamp Nut	30-0319-24
Thrust Bearing	14-9400-18
Pinion	14-9944-22
Compression Spring	14-9980-29
Steel Ball (12)	14-9420-05
Locking Disc	14-9330-31
Drive Collar	14-9340-23
Handcrank Gasket	20-0661-21
Rear Eyebolt Spacer	11-8510-40
Hex Screw 10-32 x 1 3/4" (6)	30-0329-32
Teflon Spacer	20-2664-01
Steel Spacer	20-2665-01
Support Stud (2)	14-8415-02

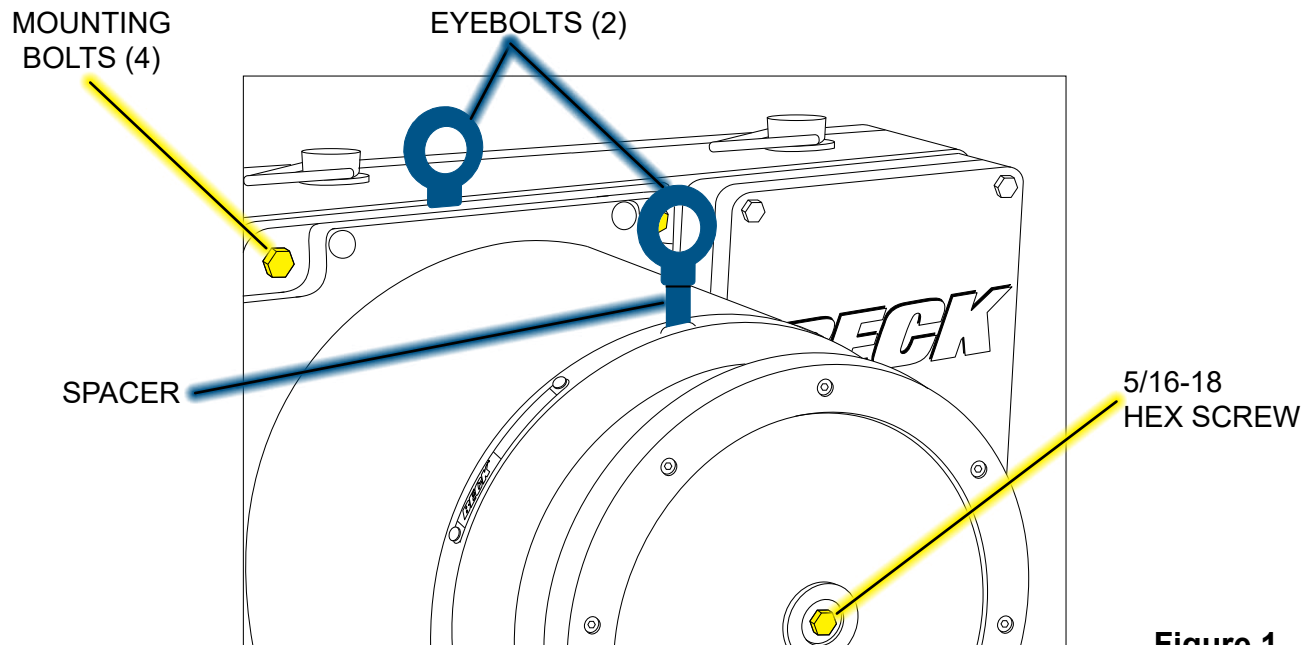

Figure 1

Use the (2) eyebolts to lift the motor only. Remove eyebolts when not servicing the actuator. Do not attempt to lift the entire actuator with the motor mounting eyebolts.

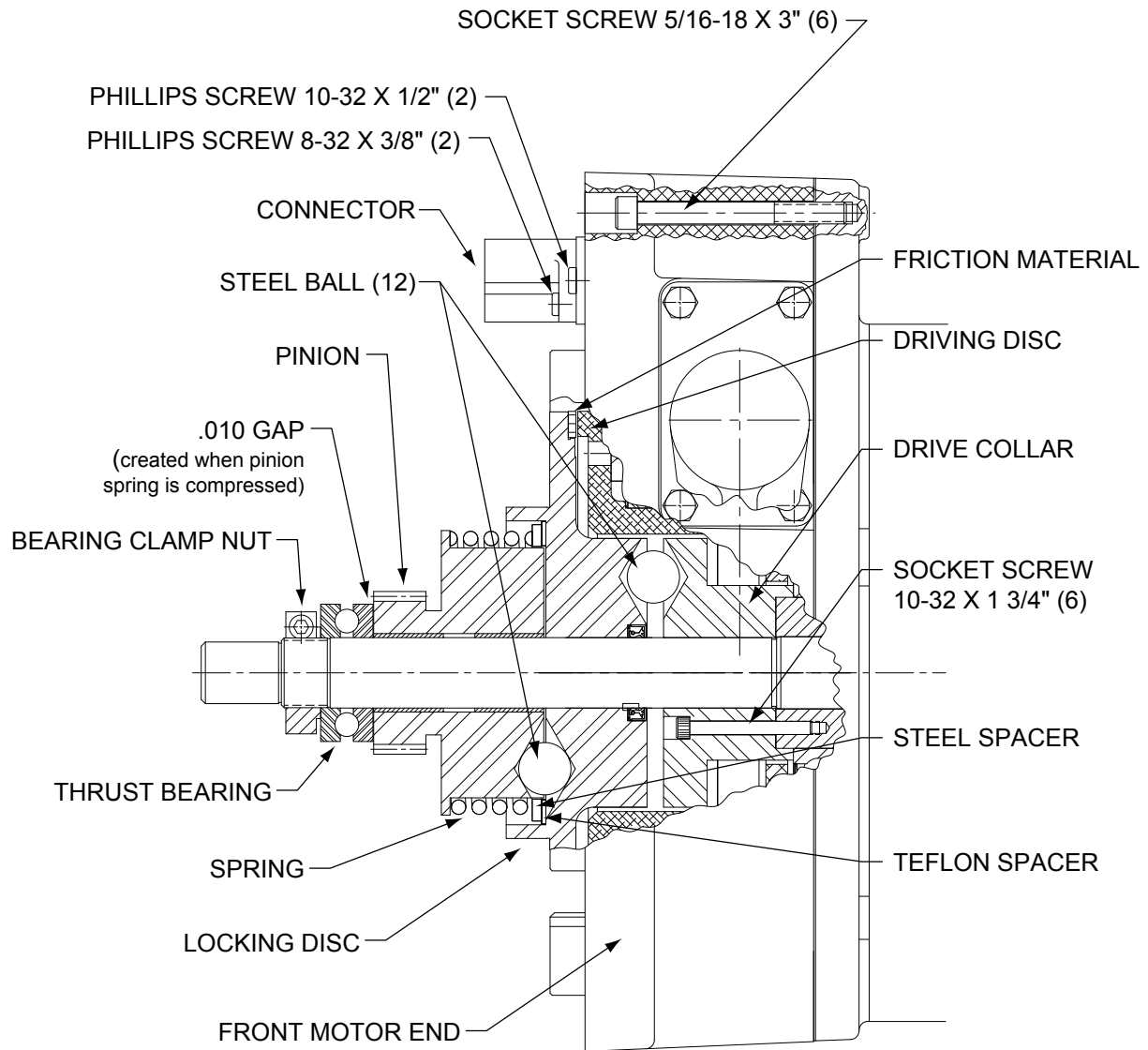

Figure 2

BECK[®] HAROLD BECK & SONS, INC.

11 TERRY DRIVE • NEWTOWN, PENNSYLVANIA 18940 • USA
 PHONE: 215-968-4600 • FAX: 215-860-6383 • E-MAIL: sales@haroldbeck.com
 www.haroldbeck.com

Made in USA 