

# **BECK**<sup>®</sup>

## **INSTRUCTION MANUAL**

---

---



**ELECTRIC ACTUATORS FOR INDUSTRIAL PROCESS CONTROL**

# INTRODUCTION

This manual contains the information needed to install, operate and maintain the Beck 75-109 compact rotary actuator, manufactured by Harold Beck & Sons, Inc. of Newtown, Pennsylvania.

The Group 75 actuator is ideal for the space-restricted hot environments typical of boiler windbox applications and other devices requiring up to 80 lb-ft (108 N•m) of torque. It is also well-suited to small rotary valve applications in tight spaces.

**IMPORTANT: This manual contains information that will make installation simple, efficient and trouble-free. Please read and understand the appropriate sections in this manual before attempting to install or operate your drive.**



**Group 11 rotary drives ...** provide precise position control of dampers, quarter-turn valves, fluid couplings, and other devices requiring up to 1,800 lb-ft (2 440 N•m) drive torque.



**Group 22 digital control drives ...** are designed for accurate, reliable, modulating, digital control of high torque applications. The drive is ideal for use in large boiler applications, such as ID/FD fan dampers.



**Group 29 linear valve drives ...** are ideally suited for globe valves from 1" to 8" (25 mm to 203 mm) diameter. Beck's unique "Tight-Seater™" coupling provides positive seating of valves.



**Group 31 compact rotary drives ...** are particularly suited for coupling to ball, plug, and butterfly valves up to 4" (102 mm) diameter, and small dampers.

# **TABLE OF CONTENTS**

---

<b>Introduction</b> .....	<b>2</b>
<b>General Specifications</b> .....	<b>4</b>
<b>Outline Dimension Drawings</b> .....	<b>6</b>
<b>Precautionary Information</b> .....	<b>8</b>
<b>General Operation Information</b> .....	<b>9</b>
<b>Installation</b> .....	<b>10</b>
<b>Mechanical</b> .....	<b>10</b>
<b>Electrical</b> .....	<b>14</b>
<b>Wiring</b> .....	<b>15</b>
<b>Start-up</b> .....	<b>16</b>
<b>Electronics</b> .....	<b>17</b>
<b>Configuration/Calibration</b> .....	<b>22</b>
<b>Maintenance</b> .....	<b>34</b>
<b>Troubleshooting</b> .....	<b>46</b>
<b>Appendices</b> .....	<b>51</b>
<b>HART® Communication</b> .....	<b>51</b>
<b>HART® Messages</b> .....	<b>58</b>
<b>Serial Communication</b> .....	<b>62</b>
<b>Serial Commands</b> .....	<b>63</b>
<b>Index</b> .....	<b>70</b>
<b>Services</b> .....	<b>71</b>

# GENERAL SPECIFICATIONS

Actuator Power	120 V ac, single-phase, 60 Hz (Standard), 50 Hz (Optional)	Allowable Tolerance	+10% -15%
----------------	--	---------------------	--------------

Operating Conditions	<p>-20° to 85°C (-4° to 185°F) - Standard.          -20° to 120°C (-4° to 248°F) - Optional (High Temperature)*.          -50° to 85°C (-58° to 185°F) - Optional (Low Temperature).          0 to 100% relative humidity.          *electronics must be remotely mounted (away from actuator installation).</p>		
Communication Interface	<p>HART protocol (Rev. 5 -- burst mode is not supported).          Local pushbutton / LED panel.          RS-232 Serial commands.</p>		
Demand Input Signal Options	<p>4–20 mA (1–5 V dc input is possible with the removal of the "R11" resistor located on the DCM-2 board (see Troubleshooting - DCM-2 Status Indication LEDs).</p>		
Demand Range Adjustability	<p>0%: 0.1 V to 4 V dc.          100%: 0% + 1 V min. to 5 V max.</p>		
Minimum Step Size	<p>0.1% (0.15% typical, configurable from 0.1 to 2.5%).</p>		
Linearity	<p>±1% of span, max. independent error.</p>		
Hysteresis	<p>0.25% of span at any point.</p>		
Demand input Signal Characterization	<b>Linear:</b>	Actuator output shaft moves proportionally to the input signal.	
	<b>Square:</b>	Actuator output shaft moves proportionally to the square of the input signal.	
	<b>Square Root:</b>	Actuator output shaft moves proportionally to the square root of the input signal.	
	<b>Custom:</b>	Actuator output shaft moves according to the configurable 10-segment response curve.	
Position Feedback Signal	<p>4–20 mA</p>		
Isolation	<p>Demand input and position Feedback signals are isolated from ground and the AC power line. Signal buffering provides 24 V dc isolation between the Demand and Feedback signals.</p>		
Action on Loss of Power	<p>Stays in place.</p>		
Action on Loss of Input Signal	<p>Stays in place or drives to any preset position (configurable).</p>		
Stall Protection	<p>If the motor tries to run in one direction for more than 300 seconds (configurable from 30 to 450 seconds), the DCM-2 will shut off power to the motor (feature can be enabled/disabled) - factory default is enabled.</p>		

Alarm Annunciation	Available at terminal 14. Configurable. 120 V ac (1 A max.).
Temperature Indication	Measures the internal temperature of the actuator and triggers an alarm when the temperature exceeds the rating.
Over-travel Limit Switches	Two SPDT switches (CW and CCW) provide over-travel protection.
Auxiliary Switches	Up to four 3 A, 120 V ac switches available (.5 A @ 125 V dc, .25 A @ 250 V dc). See Configuration/Calibration section (page 23) for switch setting diagram.
Handswitch	Permits local electrical operation, independent of controller signal. Standard on all units. An auxiliary contact is available as an option for remote auto indication (rated 3 A at 120 V ac).
Handwheel	Provides manual operation without electrical power.
Motor Assembly	120 V ac, single-phase, no-burnout, non-coasting motor has instant magnetic braking. Requires no contacts or moving parts.
Gear Train	High-efficiency, precision-cut, heat-treated alloy steel and ductile iron spur gears.
Mechanical Stops	Prevent overtravel during automatic or manual operation.
Enclosure	Precision-machined, aluminum alloy castings painted with corrosion-resistant polyurethane paint provide a rugged, dust-tight, weatherproof enclosure. Type 4X; IP68, 3 meters/48 hours*. *Internal water damage is not covered by warranty.
Maximum Output Shaft Rotation	100°.
Mounting Orientation	Any orientation—no limitations.
Standards	CSA Labeled (US & Canada)

\*For more information or to inquire about details not specifically listed, please call Beck at 215-968-4600.

# OUTLINE DIMENSION DRAWINGS

**MODEL 75-109**

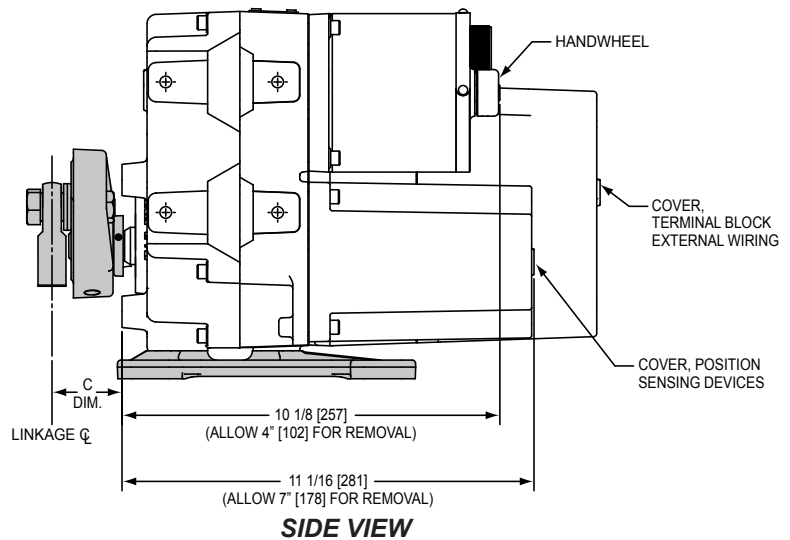
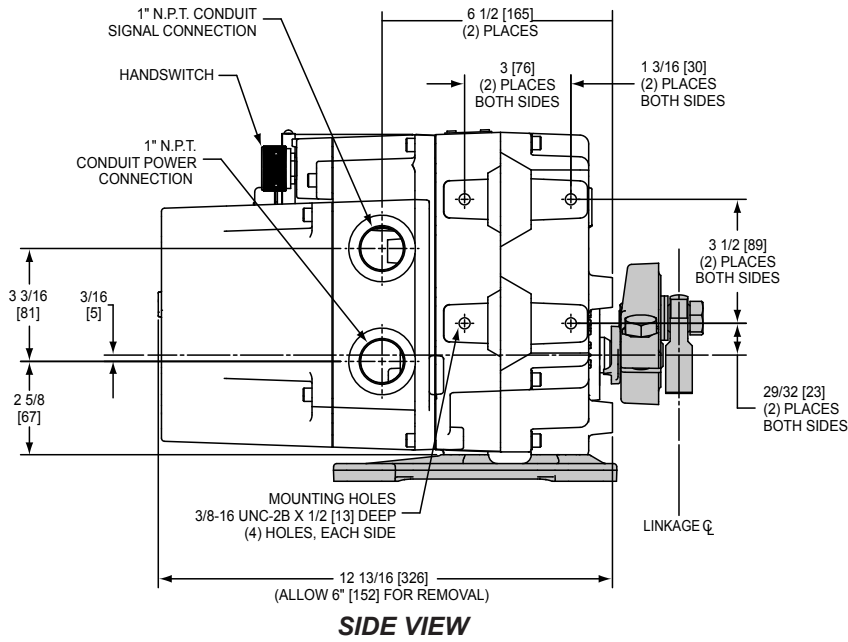
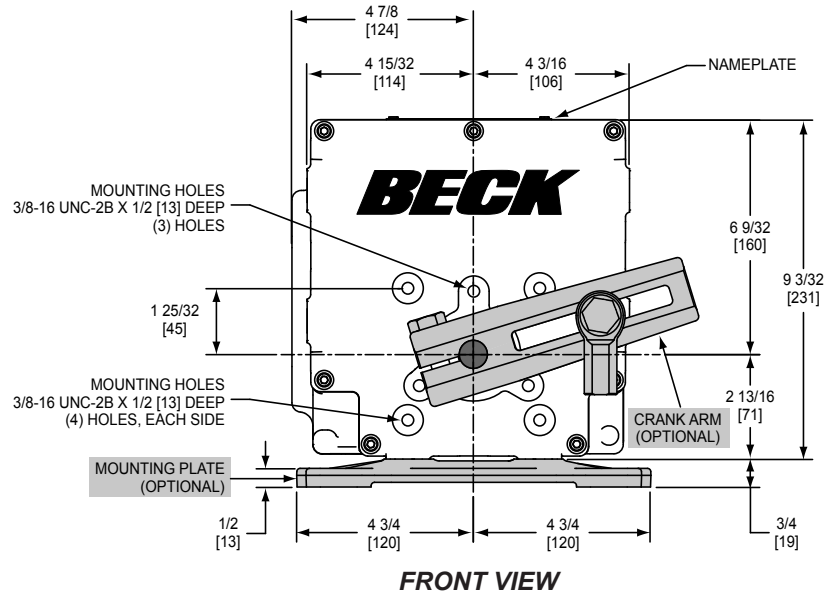

NOTE: All dimensions subject to change without notice.

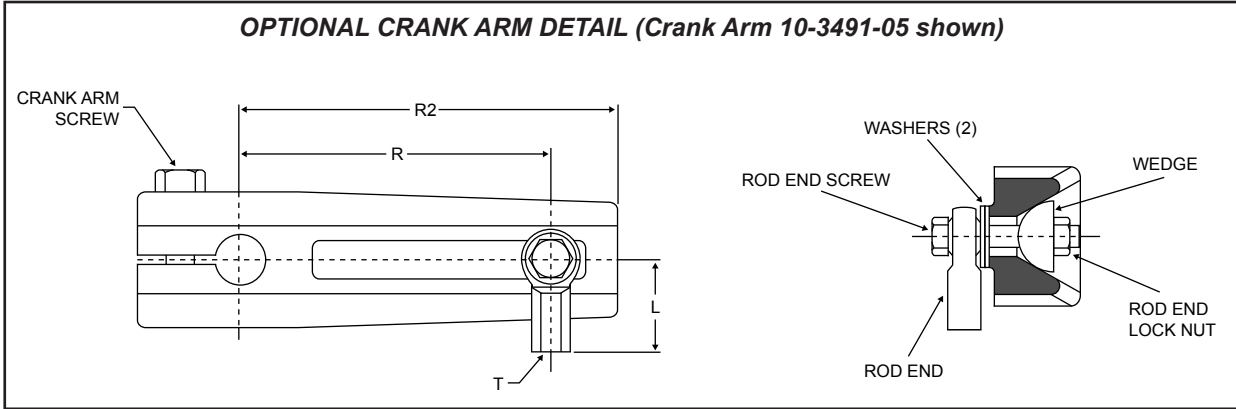
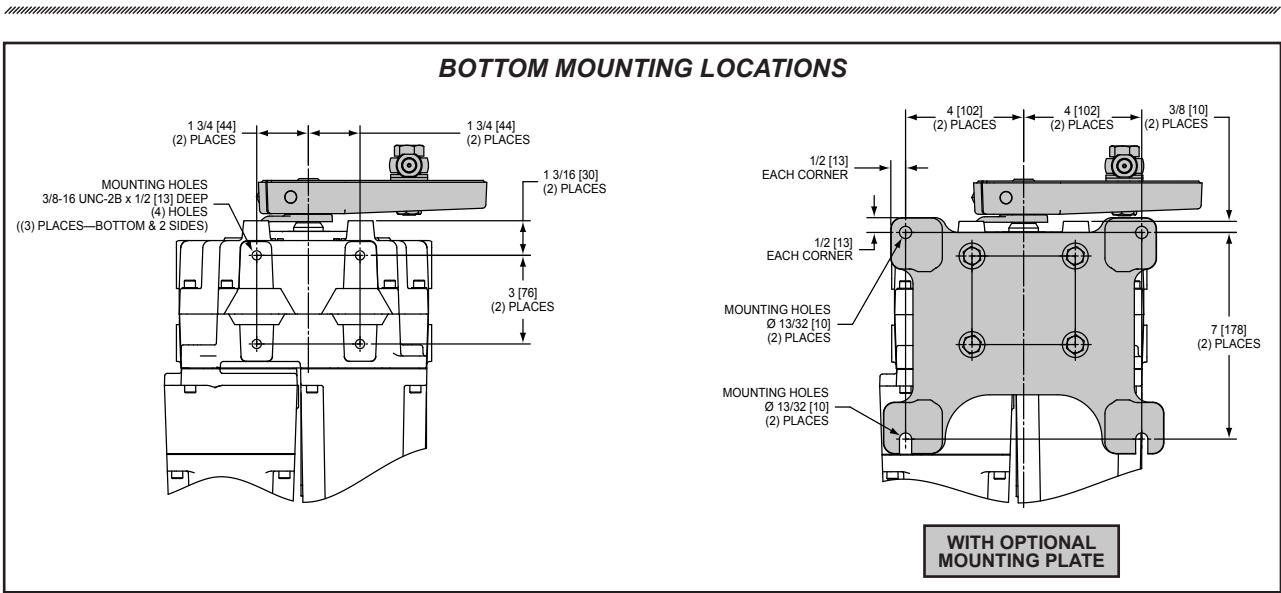

### MODEL INFORMATION

Max. Torque (lb-ft)[N·m]	Optional Crank Arm and Rod End						Output Shaft Dia. (in)[mm]	Approx. Weight (lbs)[kgs]	Maximum Overhung Load (lbs)[kgs]
	Crank Arm Part No.	Crank Arm Radius (adj.) "R" (in)[mm]	Crank Arm Radius "R2" (in)[mm]	Linkage Center to Front Mtg. Bosses "C" (in)[mm]	Rod End Length "L" (in)[mm]	Rod End Internal Thread "T" (in)[mm]			
80 [108]	10-3491-05	1 1/2-5 1/8 [38-130]	6 3/32 [155]	1 27/32-1 7/8 [47-48]	2 1/8 [54]	1/2-20 x 1 3/16 [30]	3/4 [19]	46 [21]	750 [340]
80 [108]	10-3491-52	1 1/2-4 [38-102]	4 11/16 [119]	1 21/32-1 15/16 [42-49]	2 1/8 [54]	1/2-20 x 1 3/16 [30]	3/4 [19]	46 [21]	750 [340]
40 [54]	10-3492-02	1 1/2-5 1/8 [38-130]	5 11/16 [144]	1 11/32-1 3/4 [34-44]	1 3/8 [35]	5/16-24 x 3/4 [19]	3/4 [19]	46 [21]	500 [227]

### RECOMMENDED SCREW TORQUES

	Screw Size (in)	Wrench Size (in)	Torque (lb-ft)[N·m]
Cover Screw	1/4-20	3/16	6 [8]
Motor Screw	1/4-20	3/16	6 [8]
Mounting Plate (Optional) Screw	3/8-16	9/16	20 [27]

Crank Arm Part No.	Crank Arm Screw Size (in)	Torque (lb-ft)[N·m]	Rod End Screw Size (in)	Torque (lb-ft)[N·m]	Rod End Lock Nut Size (in)	Torque (lb-ft)[N·m]	Wrench Size (in)
10-3491-05	1/2-13	75 [102]	1/2-13	35 [47]	1/2-13	55 [75]	3/4
10-3491-52	3/8-24	50 [68]	1/2-13	35 [47]	1/2-13	55 [75]	9/16 & 3/4
10-3492-02	5/16-24	20 [27]	5/16-24	20 [27]	5/16-24	20 [27]	1/2

# PRECAUTIONARY INFORMATION

## SAFETY PRECAUTIONS



### WARNING

Installation and service instructions are for use by qualified personnel only. To avoid injury and electric shock, do not perform any servicing other than that contained in this manual. Please read and understand the appropriate sections in this manual before attempting to install or operate your actuator.

## STORAGE INFORMATION

Beck actuators should be stored in a clean, dry area. Damage due to moisture while in storage is not covered by warranty.

## INSTALLATION—MECHANICAL

There are many considerations regarding proper mechanical installation—see the instructions beginning on page 10 for details. Refer to the outline dimension drawings for physical dimensions and required clearances.

## VALVE ACTUATOR INSTALLATIONS



### CAUTION

Working with valves installed in a pipeline can be dangerous. Take appropriate precautions when mounting to installed valves.

## INSTALLATION—ELECTRICAL

See the instructions beginning on page 14 for details regarding electrical installation.



### CAUTION

For maximum safety, the Beck actuator body should be grounded. Use the green grounding screw in the wiring compartment of the actuator.



### CAUTION

Always close covers immediately after installation or service to prevent moisture or other foreign matter from entering the actuator.



# GENERAL OPERATION INFORMATION

## MODES OF OPERATION

There are three basic modes of operation:

- **Handwheel**—local mechanical control
- **Handswitch**—local electrical control
- **Automatic**—remote electrical control

Any or all of these modes can be used to test basic operation of your actuator during start-up.

## HANDWHEEL

Every Group 75 Beck actuator is furnished with a Handwheel to permit manual operation of the actuator with or without power. Its solid construction design includes no spokes or projections and turns at a safe, slow speed. The Handwheel is coupled directly to the motor shaft at the rear of the motor housing and it rotates when the motor runs.

The Handwheel can be used at any time, but is particularly useful during initial installation or when power is not available. If power is available, the Handswitch should be in the STOP position before manually operating the Handwheel.

## HANDSWITCH

A Handswitch allows local electric control at the actuator. In either of the STOP positions, the motor is blocked from running. In the CW or CCW positions, the motor runs to move the output shaft in the corresponding direction. When moving the output shaft using the Handswitch, the motor will stop when the over-travel limit switches are reached.

The Demand signal can position the actuator only when the Handswitch is in the AUTO position.

## AUTOMATIC MODE

When the Handswitch is placed in the AUTO position, the actuator is in automatic mode and responds to a Demand signal (also called the setpoint). The Digital Control Module (DCM-2) compares the Demand signal with the output shaft position to determine if there is a difference. When the DCM-2 detects a difference between Demand and Position (called error), the motor will rotate the output shaft until the Position matches the Demand.

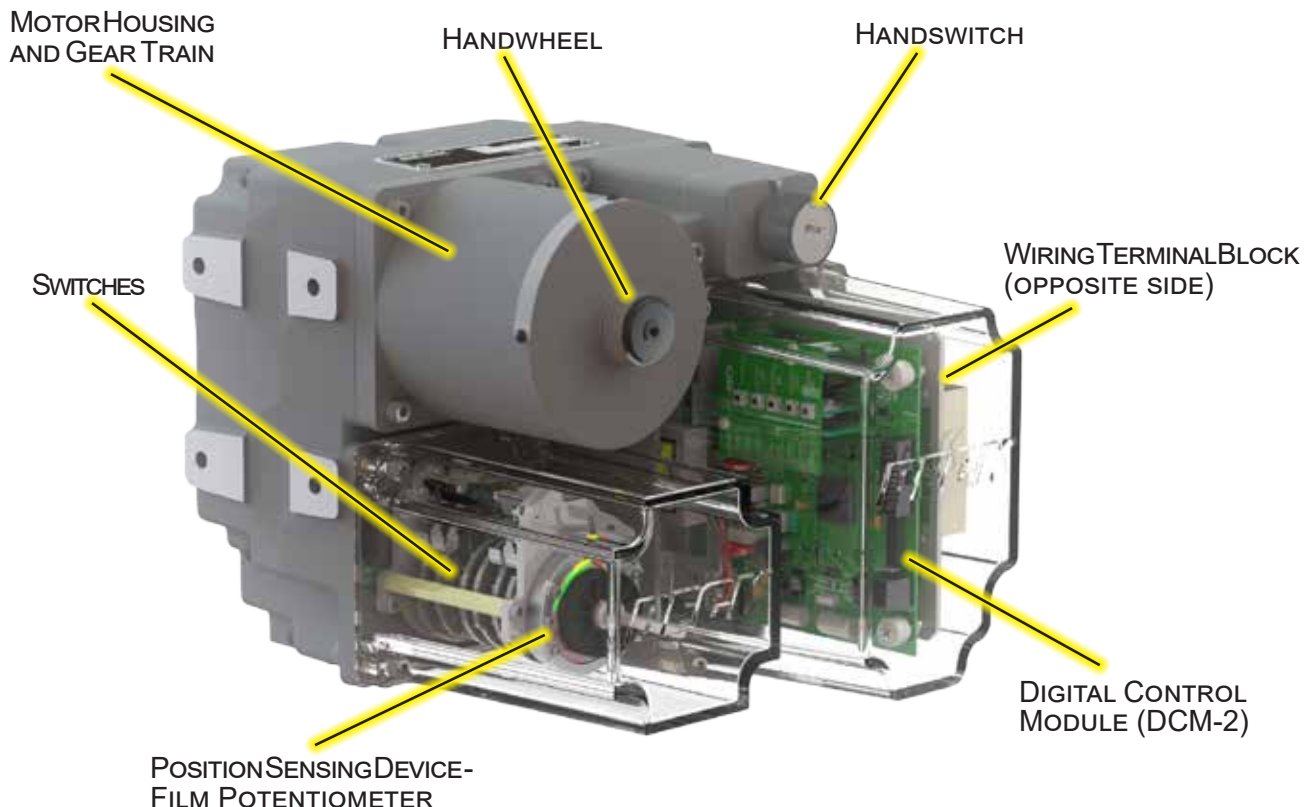

## MODEL 75-109 COMPONENTS

# **INSTALLATION Mechanical**

## **ACTUATOR MOUNTING**

Actuators may be mounted in any orientation. If mounting near obstructions such as pipes or beams, take into consideration access to the field wiring terminals, enclosure cover clearances, and the output shaft. Refer to the outline dimension drawings beginning on page 6 for the clearance necessary to remove covers.

When the actuator is bolted to a mounting plate, the plate must be rigid and must not yield to the stresses created from operating the actuator. If the mounting plate is not rigid or the mounting bolts are not sufficiently tightened, damage to the actuator housing could result. A rigid, vibration-free surface will generally prolong the life of the actuator's components. The mounting plate should be at least as thick as the diameter of the mounting bolts. An optional mounting plate is available from Beck.

Mounting bolts should be hex head steel, zinc plated (HHSZP) Grade 2 or better, 3/8"-16 and torqued to 20 lb-ft (27 N•m).

## **UNITIZED VALVE/ACTUATOR ASSEMBLY INSTALLATION**

Inspect the valve and pipe flanges to ensure they are clean. Mount the assembly according to the valve manufacturer's instruction.

## **INSTALLING LINKAGE-CONNECTED ACTUATORS**

When installing a Beck actuator in a location remote from the driven device, be sure it is firmly bolted to a flat mounting surface that will not yield to the stresses created from operating the device. A rigid, vibration-free surface will generally prolong the life of the actuator's components.

The output shaft of the actuator should be parallel to the damper or valve shaft. A crank arm is installed on the Beck output shaft. A lever arm should be installed on the driven shaft parallel to the crank arm at mid-stroke and perpendicular to the line between the two shaft centers. The linkage connecting the two arms should also be parallel to the line between the shaft centers. See the illustration at right.

A linkage connection between the crank arm and lever arm should be established. Small misalignments can be tolerated if a rod end fitting is used on the driven lever similar to that on the Beck crank arm. The actuator's crank arm can be positioned at any angle on the shaft.

Beck linkage kits are available for convenient field installation (see page 12).

## **DESIGN THE INSTALLATION**

Select a suitable mounting location that will allow for the following:

1. Clearance to remove the actuator covers.
2. A mounting base height to allow easy access and, if desired, full 360° crank arm rotation.
3. The linkage to move through its full travel without interference.
4. The actuator crank arm and damper lever arm to rotate in the same plane and the same direction.
5. The wiring conduits to be run from below the actuator to help prevent water entry.

## LINKAGE REQUIREMENTS

### (IF APPLICABLE)

For best results, the linkage should be designed in advance. In most applications, the best control will result when the linkage is adjusted so that the full 100° travel of the Beck actuator shaft is used, even though the driven lever may travel less than 100°. The general requirements for a good linkage are:

1. It must be rigid enough to carry the link thrust without bending or deforming.
2. It must have a built-in means of adjustment so that the length of the connecting link can be changed a small amount.
3. Rod end bearings, similar to those furnished on the Beck crank arm, should be used at both ends of the connecting link. This type of device permits small angular misalignments and helps prevent binding of the linkage.
4. The Beck crank arm radius must be calculated so that the arm will move through a 100° arc and the driven lever will move through its correct arc.
5. The actuator and driven shafts must be parallel and the linkage should be in a plane perpendicular to the shafts. See the example of a parallel linkage arrangement at right. Z-Linkage arrangements (where linkage ends are on opposite sides of the parallel between the driven shaft and actuator output shaft) are **not** recommended.

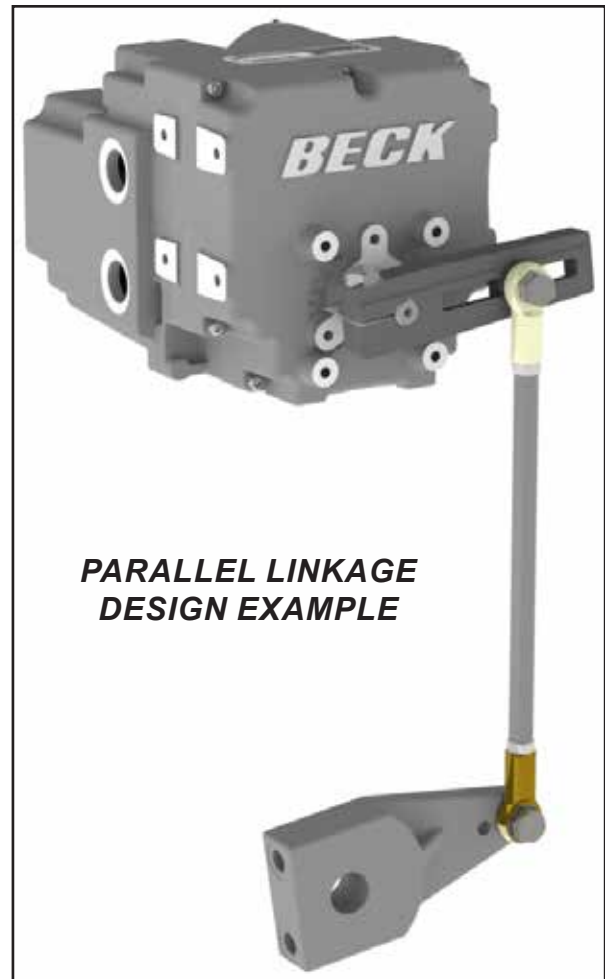

# INSTALLATION Mechanical

## LINKAGE KITS AVAILABLE

Beck linkage kits are made to accommodate a wide variation in linkage lengths without requiring modification of end fittings.

Hex Linkage kits are available for applications with linkage length requirements between 9" (229 mm) and 26" (660 mm). Each hex linkage kit comes complete with a rod end, studs, threaded hex bar, and jam nut hardware.

To order hex linkage kits, first obtain the approximate overall linkage length "A" in the hex linkage figure above. Select the kit part number from the table on the left. For lengths beyond those listed in the table, contact your Beck sales engineer.

Pipe linkage kits are available for longer linkage length requirements and include the essential linkage end connections, rod end, studs, and jam nut hardware. Schedule 40 pipe is not included and must be cut to length and threaded in the field (see table above, for instructions to calculate pipe length). To simplify installation of the pipe link, the kit accepts NPT right-hand threads on both ends of the pipe. Left-hand threads are internal to the linkage kit assembly, making final length adjustments quick and easy.

To order pipe linkage kits, first obtain the approximate overall linkage length "A" in the figure above. Select the kit part number from the table above. For lengths beyond those listed in the table, contact your Beck sales engineer.

## LINK-ASSIST™ REPORT

The Beck Link-Assist™ computer program optimizes the linkage configuration for the application load. It ensures proper setup and operation of the actuator. Contact your Beck Sales Engineer to take advantage of Beck's Link-Assist™ program. Additional Link-Assist™ information is available on the Beck website: [www.haroldbeck.com](http://www.haroldbeck.com).

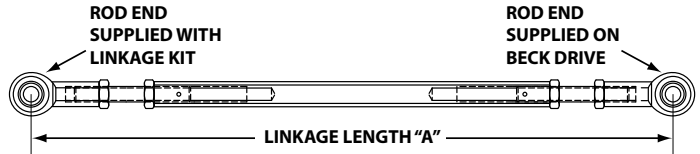

### HEX LINKAGE KITS

Linkage Length	Linkage Kit Part No.	Hex Size	Rod End Thread
9-11.5" (229-292 mm)	14-8300-22	5/8" [15.88]	1/2-20 UNF
10.5-14.5" (269-371 mm)	14-8300-32		
14.5-18.5" (368-470 mm)	14-8300-04		
18-22" (457-559 mm)	14-8300-06		
22-26" (559-660 mm)	14-8300-16		

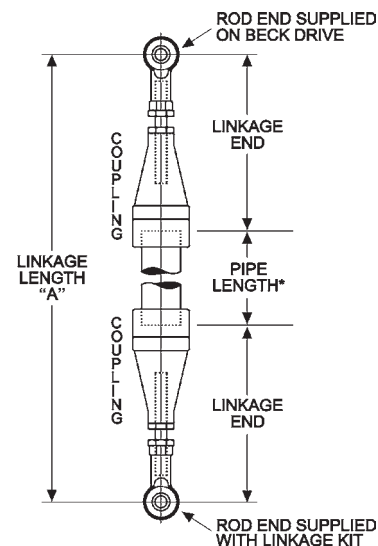

### PIPE LINKAGE KITS

Linkage Length	Linkage Kit Part No.	Pipe Size	Rod End Thread	Length of 2 Linkage Ends (+/- 1.5" (38 mm))
22-84" (559-2 134 mm)	20-1730-05	1" (25 mm)	1/2-20 UNF	20 1/2" (521 mm)
31-120" (787-3 048 mm)	20-1740-06	1.5" (38 mm)		29 1/4" (743 mm)

\*NOTE: To calculate length of pipe required, subtract "Length of 2 Linkage Ends" (shown in table above) from Linkage Length "A" (shown in diagram above).

## LINKAGE INSTALLATION

The following procedure is recommended to couple the linkage between the Beck Group 75 actuator and the driven shaft:

1. Position the driven shaft **1** to the fully closed position.
2. Set the driven shaft lever to its required starting angle **2** (predetermined with Link-Assist™).
3. Remove the rod end **3** from the Beck crank arm. Attach to the connecting link.
4. Adjust the connecting link **4** to the predetermined length.
5. Connect the connecting link to the driven lever at the predetermined radius **5**.
6. Reattach the rod end **6** to the Beck crank arm at the predetermined radius. Tighten the rod end screw to the appropriate torque (see page 7).
7. Loosen the crank arm screw **7**.



### CAUTION

The crank arm will pop free, allowing adjustment for 360° around the shaft.

8. Position the actuator's output shaft **8** to its fully closed limit.
9. Swing the crank arm into position **9**.
10. Tighten the crank arm screw **10** to the appropriate torque (see page 7).
11. Lubricate the rod end bearings.

Carefully move the actuator's output shaft to the fully open (maximum input signal) position. Check that no binding occurs between the linkage, crank arm, driven shaft lever, and surrounding obstructions. Also observe that the driven shaft rotates the proper amount. Ensure that the actuator reaches the proper limit and shuts off.

If binding in the linkage occurs due to too much travel of the driven lever, travel can be reduced by shortening the Beck actuator crank arm radius (return to Step 5 above and repeat adjustments).

To adjust the linkage length, alter the thread engagement in the stud couplings. The couplings have right- and left-hand threads, so it is not necessary to disconnect the ends to make a length adjustment. The stud threads must be engaged at least 1.25 diameters deep into the rod ends. Make adjustments by altering thread engagement in the couplings only. Be careful not to expose more than 7" (178 mm) of stud between the rod end and coupling.

## LINKAGE INSTALLATION

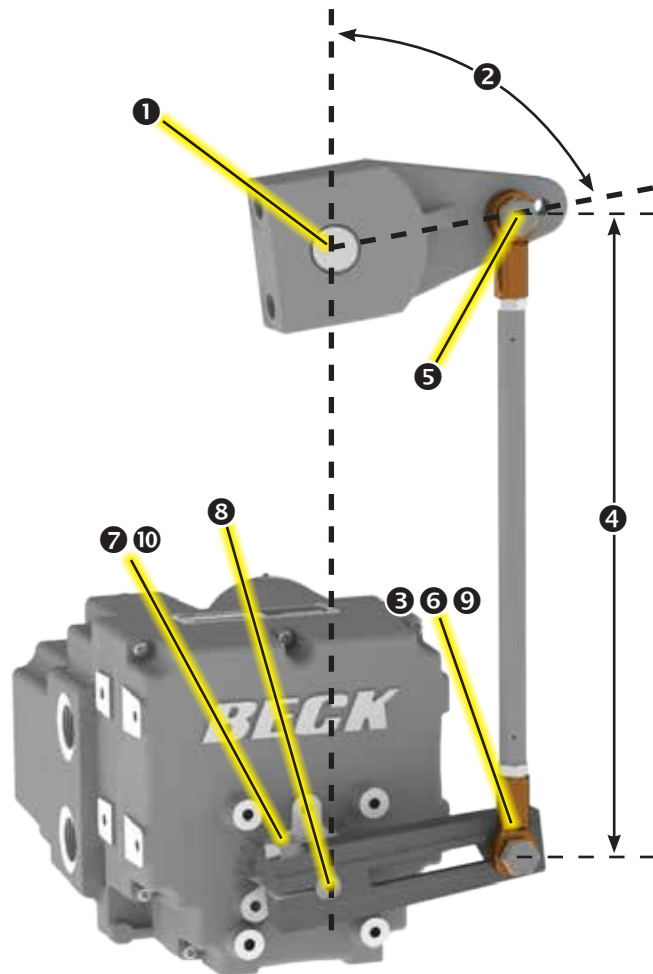

### CAUTION

The thread engagement depth in the couplings and rod ends must be greater than 1.25 x the thread diameter.

Once again, check operation to confirm that no binding occurs between the linkage and crank arm, driven lever arm, or surrounding obstructions. If necessary, further travel adjustments can be made by repeating the above steps.

Ensure that the lock nut and screw are tightened to the proper torque (see Outline Dimension Drawings).

Do not change limit switch settings to obtain desired valve or damper travel; this will adversely affect actuator operation.



# INSTALLATION *Electrical*

## POWER QUALITY

Power quality disturbances such as power outages, transient voltages, harmonic distortions, and electrical noise will adversely affect your actuator performance. Protecting your actuator from these conditions can reduce downtime and promote longer life for the equipment. Following the industry accepted standards below will help protect your actuator.

- ✦ Select wiring materials according to the correct ampacity ratings dictated by national and local regulations.
- ✦ Shielded, twisted pair cables can be used for signal connections to avoid being affected by electrical noise. These signal wires, based on Noise Susceptibility Level (NSL) per IEEE-518, fall into the level 1 classification. A braided shield will be more effective than a wrapped foil shield. Signal wire shields should be connected to the actuator casting grounding screw. If grounding at the signal source is required, then the shield should not be grounded at the actuator.
- ✦ Raceways such as conduits and trays must be grounded at both ends to properly meet immunity requirements.
- ✦ An AC power ground connection should be made between the power source and the Beck actuator. Grounding connections including wire and metal conduit are permitted, but the actuator-grounding conductor may not be connected to a structured metal frame of a building.
- ✦ Surge suppression equipment that meets Underwriters Laboratory (UL) Standard 1449 may be used to protect against transient voltage conditions.
- ✦ Power Conditioners may be used to regulate the supply voltage and maintain a constant voltage level. They are helpful in protection against voltage sags and swells, as well as some measure of electrical noise protection.
- ✦ Harmonic filters may be used to minimize the effects of supply voltage waveform distortions and are used in applications that incur a large amount of high-frequency electronic noise.



### CAUTION

**Always close covers immediately after installation or service to prevent moisture or other foreign matter from entering the actuator.**

## ELECTRICAL INSTALLATION

Two N.P.T. conduit connections are provided for power and signal wiring to the actuator. The conduit closest to the bottom of the actuator (see Outline Dimension, page 6) is provided for power and auxiliary switch connections, and the upper conduit is provided for signal wiring connections (both conduits are 1"). A sealant must be used on threaded conduit connections to keep moisture out. Conduits should be routed from below the actuator so that condensation and other contaminants cannot enter the actuator through the conduit.

Power and signal wires should be routed to the actuator separately and be either shielded cables or installed in conductive conduit and/or cable trays.

Refer to the wiring diagram furnished with your Beck actuator for proper AC power and signal connections. The customer must supply 120 V ac to power the actuator. The 120 V ac line connects to terminal 1 and neutral to terminal 2.

It is advisable to provide normal short circuit protection on the AC power line. A copy of the wiring diagram may be found inside the terminal compartment on the back of the electrical warning shield covering the terminal block. You may obtain a copy of the wiring diagram from Beck by providing the Serial number of your actuator.

Connection of a 4–20 mA Demand signal should be made to terminals 24 (+) and 23 (–).

For maximum safety, the Beck actuator body should be grounded. Use the green grounding screw in the wiring compartment of the actuator.

## TERMINAL SCREW TORQUES

Each terminal screw should be torqued to 5 lb-in (0.6 N•m) upon landing the wire.

# INSTALLATION Wiring

## TERMINAL CONNECTIONS

Terminals accept #30–12 AWG wire. Terminal screws should be torqued to 5 lb-in (0.6 N•m). Ground screws should be torqued to 13 lb-in (1.5 N•m).

Each Beck actuator is custom built to match the control requirements of your system (specified at the time of order).

Each actuator has a specific wiring diagram printed on the reverse side of the electrical warning shield that covers the terminal block. Typical wiring connections are shown below.

Each actuator can be ordered with up to four optional auxiliary switches. Wiring connections for these are described in the CONFIGURATION/CALIBRATION section of the manual, beginning on page 22.

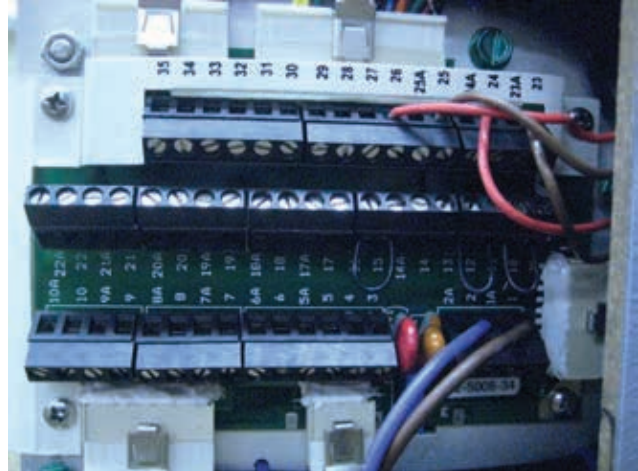

To prevent Handswitch-initiated motion, remove jumper (JA) from between terminals 11 and 1B.



**CAUTION**  
AC power to the actuator must be turned off before removing the jumper (JA).

## TYPICAL WIRING CONNECTIONS

(Each actuator has a specific wiring diagram on the reverse side of the electrical warning shield)

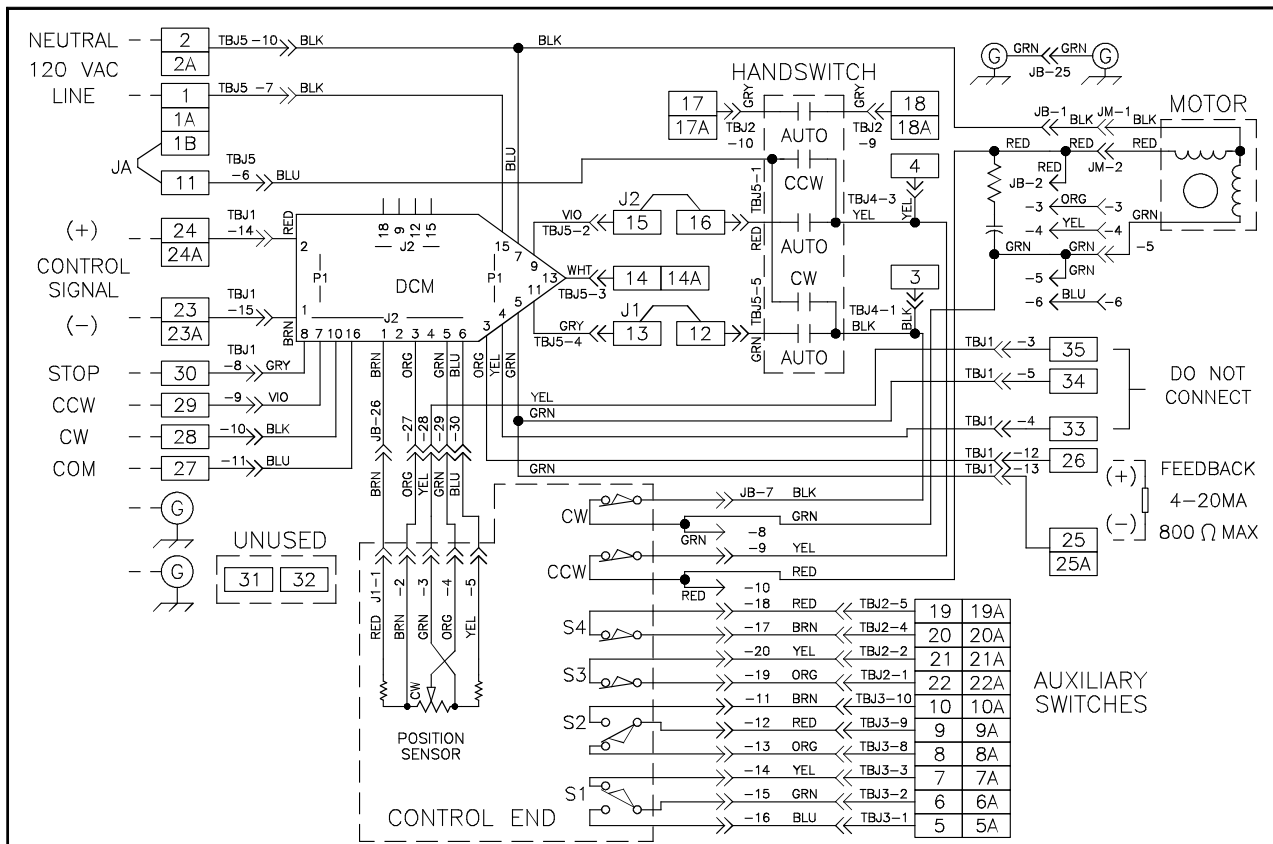

# START-UP

## START-UP

**NOTE: All Beck actuators are shipped from the factory ready for installation. Each actuator is set-up and calibrated to the customer's specifications that were written into the equipment order. Electrical adjustments are generally not required before placing the actuator in operation.**

## START-UP CHECKLIST

The following list provides some basic checks that should be performed before placing your actuator into operation.

- Inspect the location and the mounting bolts. Be sure the actuator is securely fastened to its mounting base.
- On the first start-up, place the Handswitch in a STOP position to ensure that the output shaft will not move and possibly cause personal injury.
- Confirm the actuator is receiving the appropriate operating voltage as shown on the nameplate.
- Check the DCM-2 Power LED. It should be pulsing (Dim/Bright) to indicate the board is active.
- Using the Handswitch, confirm the actuator moves fully to both the CW and CCW ends of travel.
- Confirm the actuator has a 4–20 mA Demand signal attached to terminals 24 (+) and 23 (–).
- Place the Handswitch in AUTO and vary your Demand signal from 0% to 100%.
- Check for the Status alarm LED on the DCM-2. If it is lit, refer to the Troubleshooting section of this manual (page 48).
- Verify that the output shaft is moving to the desired 0% position with a 0% Demand signal and moving to the 100% position with a 100% Demand signal. If they are reversed, see page 24 of this manual for instructions on how to change the direction of output shaft rotation.



# ELECTRONICS

## CONTROL END & FILM POTENTIOMETER

The actuator "control end" compartment houses the limit switch assemblies and the film potentiometer. The film potentiometer is the electro-mechanical device that provides the DCM-2 with a continuous feedback signal proportional to the position of the actuator's output shaft.

The control end includes a control shaft, which is geared directly to the output shaft of the actuator. Rotation of the output shaft causes rotation of the control shaft, which in turn moves the limit switch cams and the potentiometer's insulator/wiper assembly. The DCM-2 measures the output voltage from the potentiometer in order to determine the position of the output shaft.

The 1,000 $\Omega$  film potentiometer has a power dissipation of 2 W max. at 85°C (185°F). The wiper current is 1 mA max. Position signal voltages can be measured between test points TP1 & TP4 located on the DCM-2.

Two SPDT over-travel limit switch assemblies (labeled "CW" and "CCW") are provided with the actuator and up to four auxiliary switch assemblies (labeled "S1" through "S4") are available.

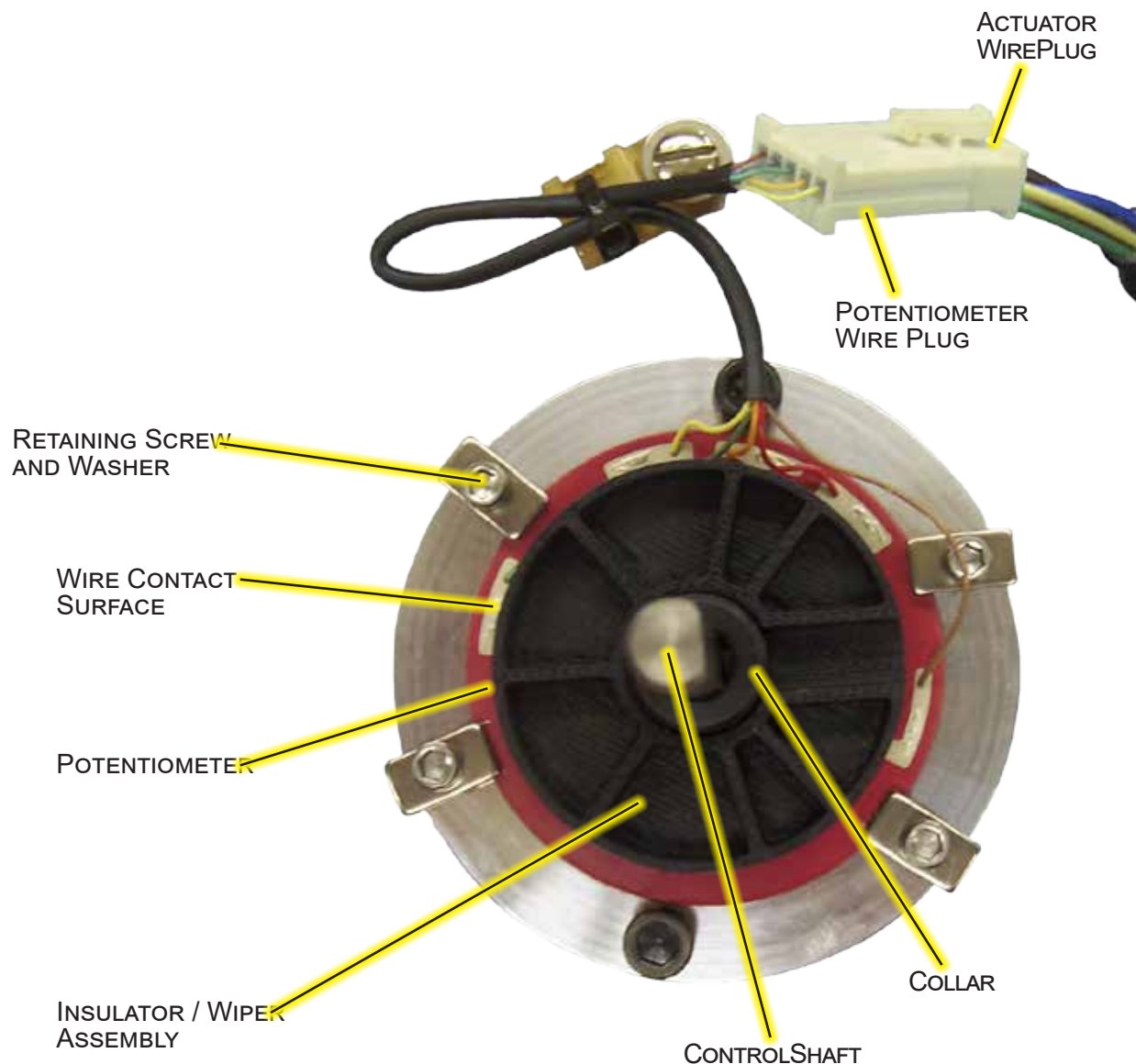

**Film Potentiometer**

# ELECTRONICS

## DIGITAL CONTROL MODULE (DCM-2)

The DCM-2 is a micro-processor based circuit board assembly that serves as the actuator's control center.

The main function of the DCM-2 is to position the actuator's output shaft. The DCM-2 compares the 4–20 mA signal received at the actuator Demand terminals (24 (+) and 23 (-)) to the actuator Position signal generated from the film potentiometer (see "Automatic Mode", page 9).

The DCM-2 layout (see page 20) shows the fuse and test point locations. The typical Position signal voltage from the film potentiometer (measured from TP1(-) and TP4(+)) ranges from 1.0 V dc at the CCW end of output shaft travel, to 5.0 V dc at the CW end of output shaft travel. Test point voltage levels between TP2(+) and TP3(-) across the input resistor R11 should read between 1 V dc and 5 V dc proportional to the 4–20 mA Demand signal.

## DIGITAL CONTROL MODULE (DCM-2)



## INTERFACES

The DCM-2 has three configuration interfaces: Local Pushbutton, HART, and Serial Port.

### LOCAL PUSHBUTTON

The DCM-2 board is equipped with a local pushbutton panel that can be used to calibrate the Demand signal and configure 0% and 100% positions. It may also be used to configure the direction of output shaft rotation for increasing Demand. These configurations and calibrations do not require any external equipment to perform.



**DCM-2 Local Pushbutton Panel**

### HART

The HART interface is accessible by connecting a HART capable communication device (such as a handheld communicator) to terminals 24 (+) and 23 (-) of the terminal block area. A HART-capable, analog output device can be used for the Demand signal as well. All electronic calibration and configuration can be accomplished through the HART interface. NOTE: The appropriate HART device descriptions are required.

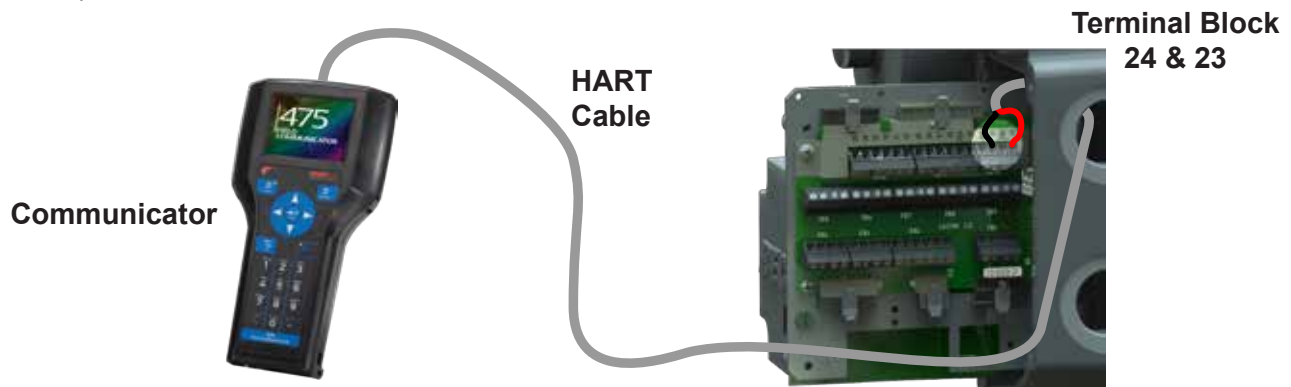

### Serial PORT

The Serial port interface is accessible by connecting a computer to the DCM-2 using a Beck Serial cable. See the Serial Communications appendix for details on connecting via the Serial port. All electronic calibration and configuration can be accomplished through the Serial port interface.

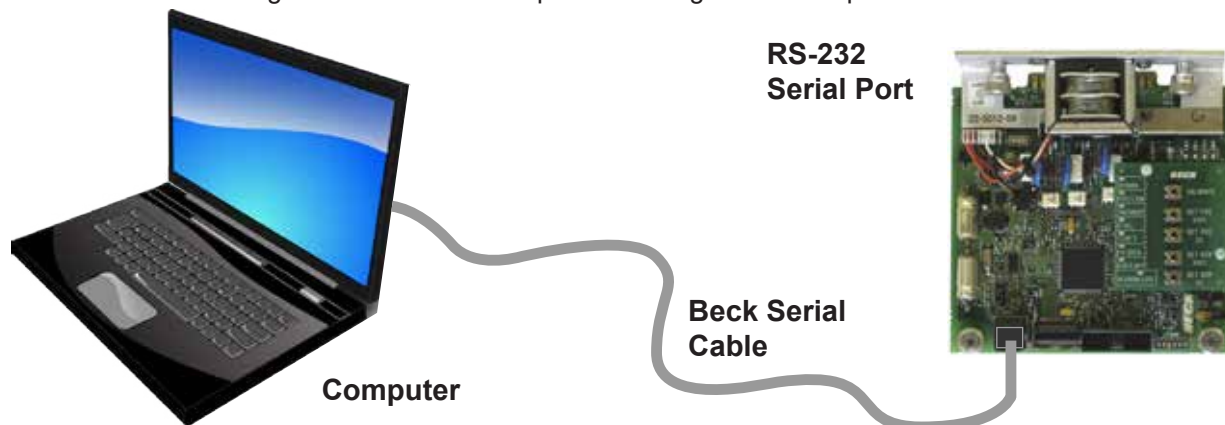

# ELECTRONICS

## DCM-2 LAYOUT

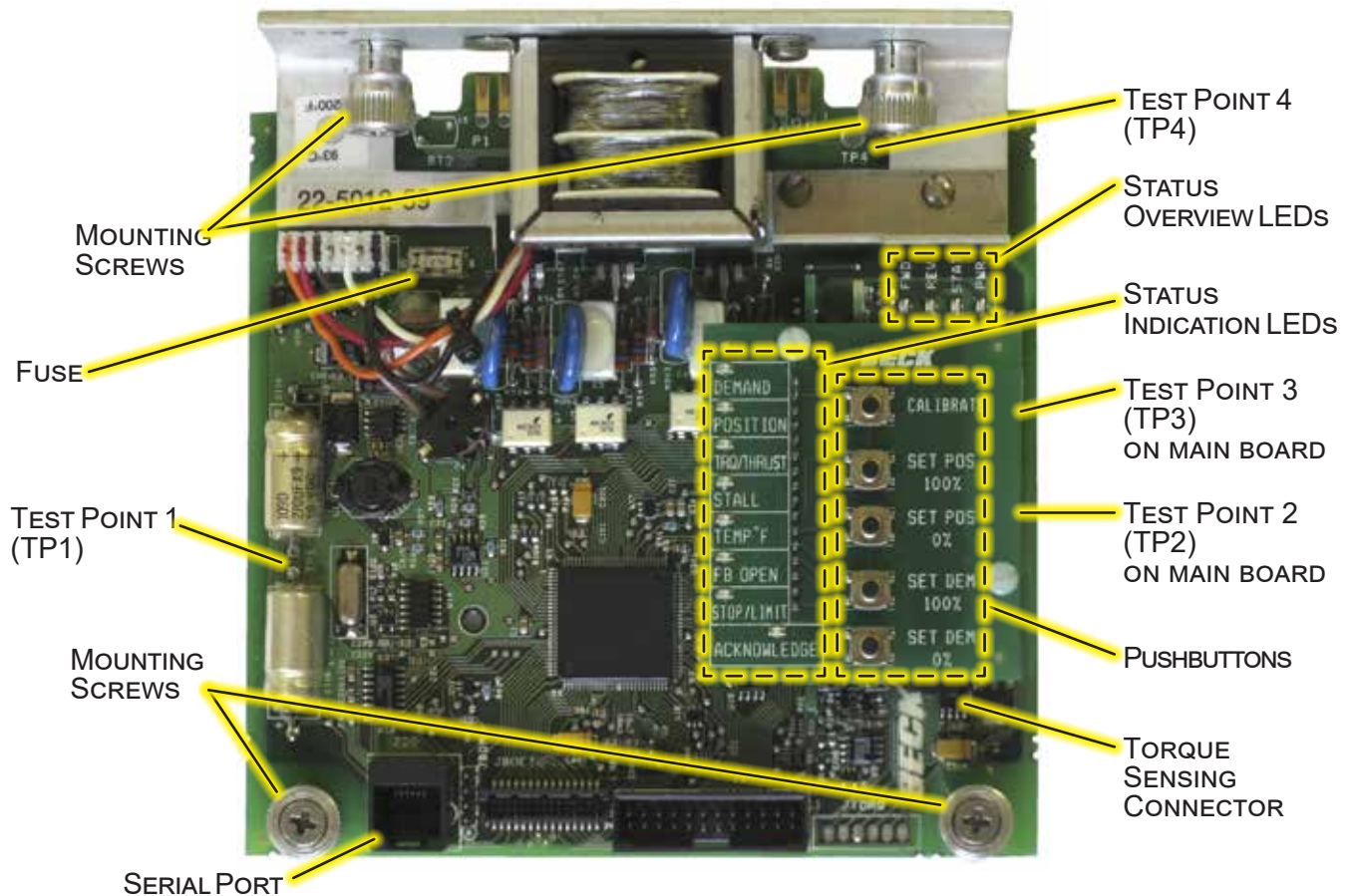

## OVERVIEW LEDS

There are four LEDs that reside on the main DCM-2 board (pictured above). These LEDs indicate the basic, real-time state of the actuator. A description of each LED follows.

### FWD

This LED illuminates when the actuator is receiving a Demand signal greater than its position.

### REV

This LED illuminates when the actuator is receiving a Demand signal less than its position.

### STAT

This LED illuminates during a system alarm. Explanation of the specific alarm is available through the fieldbus or Serial interface. See the troubleshooting section for additional information.

### PWR

This LED illuminates when power is applied to the actuator. This LED pulses from bright to dim indicating the DCM-2 is operational.



**OVERVIEW LEDs**



## STATUS INDICATION LEDs

When the “STAT” LED is lit, the applicable status indication LED(s) (pictured below) will light to reveal the condition(s) as described below. An alarm is also available at terminal 14. When the condition is corrected, the status will automatically reset. Each status LED is described below.

### DEMAND

Loss of the Demand input signal.

### POSITION

The Position signal to the DCM-2 is out of the calibrated range limits. The lower limit is –5% and the upper limit is 105% of the calibrated range. This LED may also indicate a film potentiometer or internal wiring failure.

### TORQ/THRUST

This LED is inactive for Group 75 actuators.

### STALL

The drive is in a stall condition and stall protection has been activated.

### TEMP °F

Drive’s internal temperature is outside of rating.

### FB OPEN

External position Feedback signal is enabled, but not wired to an external load or the wiring has failed between the drive and the monitoring device.

### STOP/LIMIT

Handswitch is in “STOP” position or the drive is at a limit and is not in balance.

### ACKNOWLEDGE

Indicates when a calibration procedure has been completed.

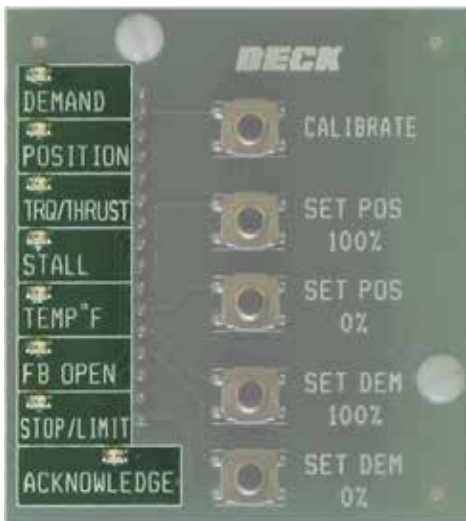

**STATUS INDICATION LEDs**

## PUSHBUTTON CONTROLS

The five pushbuttons (pictured below) on the DCM-2 customer interface panel are used for calibration. When pressing a pushbutton, pressure should be maintained until the “ACKNOWLEDGE” LED lights; this confirms receipt of the pushbutton command. See the CONFIGURATION/CALIBRATION section for further explanation of calibration procedures.

### CALIBRATE

A safety feature, this button must be pressed and held simultaneously with another pushbutton to perform a calibration.



### **CAUTION**

**Pressing the following buttons may change calibration and cause the drive to reposition.**

### SET POS 100%

Press to designate the current position of the output shaft as the 100% position for drive movement (this will correspond to a 100% Demand signal).

### SET POS 0%

Press to designate the current position of the output shaft as the 0% position for drive movement (this will correspond to a 0% Demand signal).

### SET DEM 100%

Press to designate the current Demand input signal as 100% Demand.

### SET DEM 0%

Press to designate the current Demand input signal as 0% Demand.



**PUSHBUTTON CONTROLS**

# CONFIGURATION/CALIBRATION

**NOTE:** Your Beck actuator was shipped from the factory ready for installation; no electrical adjustments are required before placing it in operation. Each actuator is set up and calibrated to the specifications that were written into the equipment order.

Under normal operating conditions there is no need to recalibrate the actuator. However, if the application requirements change—or are different than specified on the equipment order—the actuator should be recalibrated according to the following procedures.

## LIMIT SWITCHES

Actuators are shipped with over-travel limit switches factory-set for 101° of travel unless otherwise specified at time of order. Limit switches must be set inside the range of the built-in, non-adjustable mechanical stops to prevent the possibility of stalling when operating the actuator with the Handswitch. Limit switches can be reset to limit over-travel of the output shaft when travel of the output shaft has been reduced (60° minimum) (see page 26).

**NOTE:** The over-travel limit switches are the switches closest to the actuator body. To adjust the over-travel limit switches, it is necessary to remove the control end cover.

Switches are operated by cams which are clamped onto the control shaft. In the following procedure, the use of a continuity meter is recommended to determine when the switch opens or closes. If such a meter is not available, it is possible to hear the switch click as the contacts open and close.



### CAUTION

**Do not attach the meter or attempt to adjust the switch cams until the actuator is disconnected from the line voltage and auxiliary switches are disconnected from external power sources.**

## SETTING OVER-TRAVEL LIMIT SWITCHES CW AND CCW

This procedure should be used if the factory over-travel limit switch settings must be changed in the field. It is advisable to operate the actuator fully in each direction, using the electric Handswitch to check switch settings before attempting to change them. Follow these instructions if they require adjustment:

1. Remove the control end (position sensing device) cover and terminal block cover (3/16" hex wrench).
2. Move the output shaft to the desired CW limit.
3. Turn the Handswitch to the "STOP" position.
4. **Disconnect power from the actuator.**
5. Connect a continuity meter across terminals 2 and 3.
6. Insert a small screwdriver into one of the slots on the CW cam. Carefully rotate the cam until the meter shows no continuity (switch contacts open, switch clicks).
7. Disconnect meter and ensure the Handswitch is in the "STOP" position.
8. Reconnect actuator power.
9. Rotate the actuator's output shaft in the CCW direction away from the CW travel limit. Note the direction of rotation on the lobe of the cam. The correct cam lobe motion is away from the switch lever with the switch lever on the lower part of the cam. If not correct, return to step 2 and adjust the cam position such that the opposite end of the lobe presses against the switch lever at the desired "trigger" position of the output shaft.
10. Rotate the output shaft again to the desired CW travel limit. If the stopping point is reached, the switch is properly set.
11. Repeat instructions 2–10 for setting the CCW travel limit switch (noting that referenced directions of rotation should be opposite of those used for the CW switch setting). Connect continuity meter across terminals 2 and 4.
12. Replace covers and tighten cover screws to 6 lb-ft (8 N•m) torque.
13. If applicable, rotate the index pointer on the output shaft to correspond with the new output shaft position range.

## SETTING AUXILIARY LIMIT SWITCHES

Standard switch settings for actuators with 2 or 4 auxiliary switches are shown on the following diagram "Standard Over-travel Limit and Auxiliary Switch Settings". The heavy line indicates a closed circuit. Follow these instructions to change the operating point of auxiliary switches:

1. Remove the control end cover and the terminal block cover (3/16" hex wrench).
2. Move the output shaft to the desired switch trip position.
3. Turn the Handswitch to the "STOP" position.
4. **Disconnect power from the actuator and switch terminals.**
5. Connect the continuity meter across the appropriate terminals. See the wiring diagram under the terminal block cover (if not available, reference the diagram at right).
6. Insert a small screwdriver into one of the slots on the appropriate cam and rotate until the cam operates the switch.
7. Disconnect the meter and reconnect power.
8. Move the actuator's output shaft in the desired direction to verify that the cam lobe moves away from the switch lever. If not correct, return to step 2 and adjust the cam position such that the opposite end of the lobe presses against the switch lever at the desired "trigger" position of the output shaft.
9. Replace covers and tighten cover screws to 6 lb-ft (8 N•m) torque.

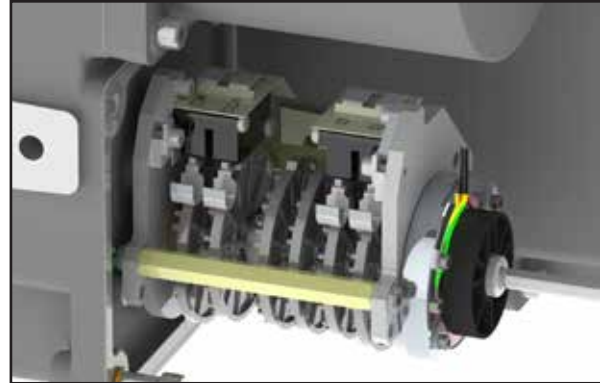

**LIMIT SWITCH CAMS**

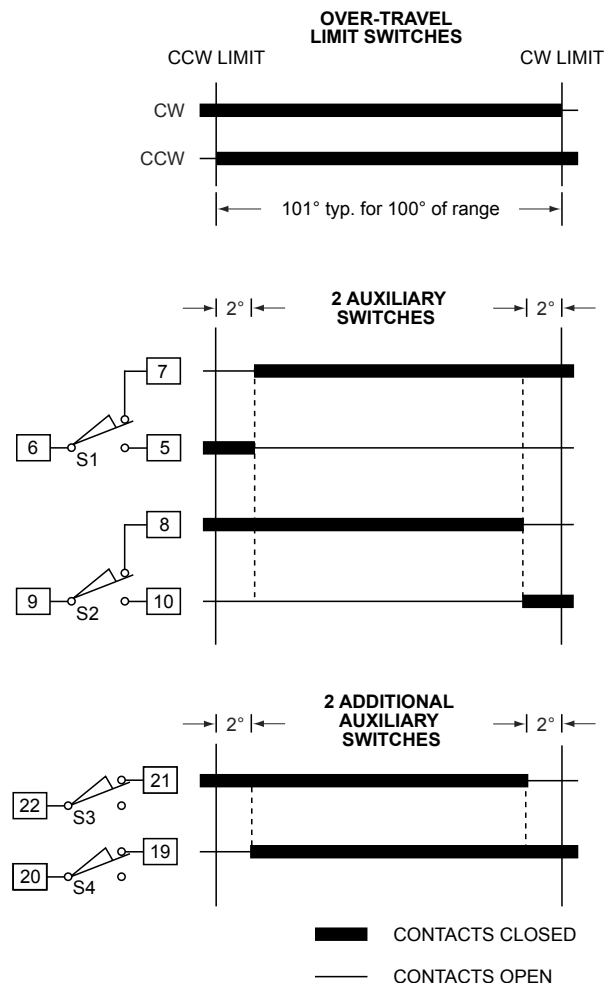

**STANDARD OVER-TRAVEL LIMIT AND AUXILIARY SWITCH SETTINGS**

# CONFIGURATION/CALIBRATION

## DIRECTION OF OUTPUT SHAFT ROTATION

Rotation direction refers to the direction the output shaft of the actuator rotates in response to an increasing Demand input signal. The rotation is either clockwise (CW) or counterclockwise (CCW) as shown in the figure below (depicted with optional crank arm). The rotation of the driven load (e.g., damper lever arm) determines the actuator rotation suitable for an application.

Unless otherwise specified at the time of order, the output shaft is factory set to rotate clockwise in response to an increasing Demand signal. The direction of rotation can be easily changed using one of the following three methods. After changing the output shaft rotation, adjust the travel index pointer (optional) on the output shaft to reflect the correct 0% and 100% positions.

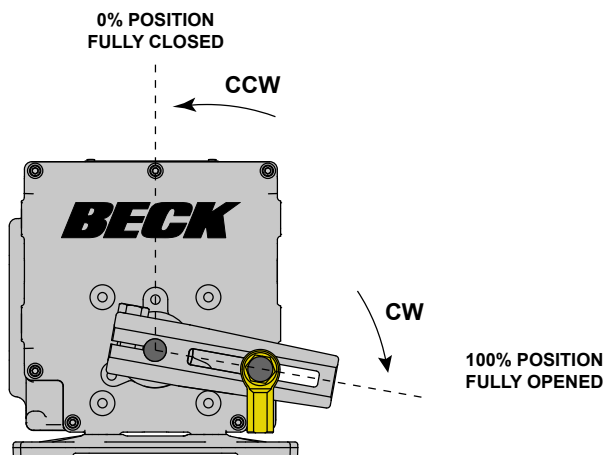

**NOTE:** The crank arm in the figure above may be adjusted to any start angle. The orientation and rotation shown here has been randomly selected for the purpose of this example.

## PUSHBUTTONS method

1. Remove the DCM-2 cover (3/16" hex wrench).
2. Position the drive at the current 0% position.
3. Press and hold the "CALIBRATE" pushbutton on the DCM-2 local interface panel, then press the "SET POS 100%" pushbutton until the "ACKNOWLEDGE" LED is lit.\*

—OR—

2. Position the drive at the current 100% position.
3. Press and hold the "CALIBRATE" pushbutton on the DCM-2 customer interface panel, then press the "SET POS 0%" pushbutton until the "ACKNOWLEDGE" LED is lit.\*
4. Ensure the drive operates as desired.
5. Replace the DCM-2 cover and tighten the cover bolts to 6 lb-ft (8 N•m) torque. Reset travel index.

\* If the "ACKNOWLEDGE" LED does not light, but the "POSITION" LED does light, the change was not accepted by the DCM-2.

**NOTE:** When either of the above procedures is performed, both the 0% and 100% positions are automatically set.

## HART method

**Command:** Drive Dir

**DD Menu Location:** MENU 4B

Functions>Configuration>General Setup

**Selections:**

**CW Incr** - select if the desired output shaft rotation is clockwise on increasing Demand signal.

**CCW Incr** - select if the desired output shaft rotation is counter-clockwise on increasing Demand signal.

## Serial command method

**Command:** drvdir *n*

**Arguments:** *n*

**0:** CW - select if the desired output shaft rotation is clockwise on increasing Demand signal.

**1:** CCW - select if the desired output shaft rotation is counter-clockwise on increasing Demand signal.



## STEP SIZE

Step size represents the minimum amount that the Demand signal must change to initiate a change in actuator position.

When the actuator is in AUTO mode, the DCM-2 runs the motor until the output shaft position matches the percentage of Demand signal. When they match, power is removed from the motor. The Demand signal must change by the step size before power is returned to the motor.

The step size is factory set to 0.15% of full travel span, unless otherwise specified at the time of order. The step size is adjustable from 0.1% to 2.5% when the actuator is configured for 100 degrees of travel. Adjustment is typically not required. The minimum step size regardless of travel is 0.1°.

It may be advantageous in certain applications, where noise or other problems exist, to increase the step size slightly to prevent excessive modulation.

The step size can be changed using the following methods.

### HART method

**Command:** StepSize

**DD Menu Location: MENU 4B**

Functions>Configuration>General Setup>

Enter the desired step size between "0.10%" and "2.50%".

### Serial command method

**Command:** stepsize #.##

**Arguments:** #.## Desired step size (in degrees) of one incremental movement of output shaft travel. Acceptable range is between "0.10" and "2.50".

**NOTE: Changing this parameter online could cause the actuator to reposition.**

## RESTORE FACTORY SETTINGS

All DCM-2's are shipped from the factory configured per the customer instructions at the time of order. A complete copy of the factory configuration is stored on the DCM-2. You can revert to the factory settings at any time through one of the following methods.

**NOTE: When the factory settings are restored, the Operation Mode (HART DD menu location 3E or Serial command "opmode") will not be changed for safety reasons. The operation mode should be set to "Follow" for normal automatic operation.**

### HART method

**Command:** Restore to Factory

Running this function will restore all configurable parameters to the original factory settings.

**DD Menu Location: MENU 3C**

Functions> Configuration

### Serial command method

**Command:** restoremodes *n*

**Arguments:** *n*

**1:** Used as a safety measure, the number one must be entered as an argument to prevent someone from running the restoremodes command errantly.

# CONFIGURATION/CALIBRATION

## TRAVEL (DEGREES ROTATION)

Travel is defined as the number of degrees of rotation by the output shaft between the 0% and 100% positions. Unless otherwise specified, all models are factory configured for the maximum travel allowable, which is 100 degrees of output shaft rotation.

It is recommended that the maximum travel be utilized to obtain full output torque of the actuator and maximum resolution of movement. On linkage-connected actuators it is possible to utilize the maximum travel of the actuator when the driven load rotation is less than 100 degrees, for example 90 degrees of damper or valve travel. A free Link-Assist analysis can be provided by a Beck sales or application engineer. Link-Assist Service information is available for review on the [haroldbeck.com](http://haroldbeck.com) website.

Some exceptional applications may require less actuator travel. Travel calibration can be performed to reduce actuator travel. Travel less than 60 degrees is not recommended.

It is possible to change the full travel of the actuator output shaft if necessary. To change the Beck output shaft full range of rotation, electronic calibration changes can be made by using one of the two procedures below. These procedures can be performed by using the methods that follow.

- 0% and 100% Position Calibration:** Physically drive the actuator to the new 0% and 100% positions. Use the Pushbutton or HART method to set the new end points.
- Changing Travel in Degrees:** Allows the calibration to be changed without moving the drive output shaft. Use the HART or Serial command method to set the desired full travel rotation in degrees. The 0% position will remain the same, but the 100% position will change to accommodate the new travel setting.

**NOTE:** In addition to recalibrating the electronics, the CW / CCW over-travel switches should also be adjusted to open just beyond the new electronic limits; this ensures that manual operation with the Handswitch will not cause over-travel or create a stall condition.

*Calibrate the 0% and 100% positions:*

### PUSHBUTTONS method

1. Move the output shaft to the desired 0% position.
2. Press and hold the "CALIBRATE" pushbutton then press the "SET POS 0%" pushbutton until the "ACKNOWLEDGE" LED is lit.
3. Move the output shaft to the desired 100% position.

4. Press and hold the "CALIBRATE" pushbutton then press the "SET POS 100%" pushbutton until the "ACKNOWLEDGE" LED is lit.
5. Adjust over-travel limit switches as necessary to accommodate the new rotation.

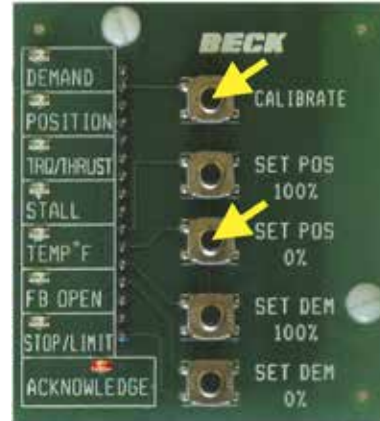

SET  
0%  
POSITION

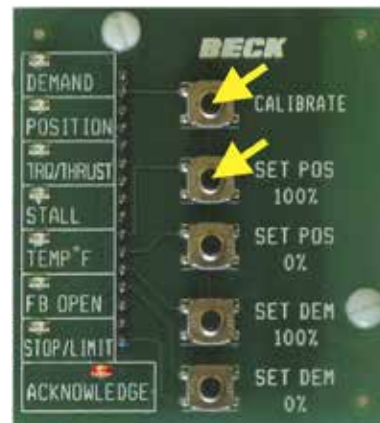

SET  
100%  
POSITION

### HART method

**Command:** Set Pos 0%

Select when the output shaft is at the desired 0% position.

**Command:** Set Pos 100%

Select when the output shaft is at the desired 100% position.

**DD Menu Location:** MENU 4C

Functions>Configuration>PositionSensrSetup>

**Change travel:**

### HART method

**Command:** Travel

Enter the desired full stroke rotation in degrees.

**HART DD Menu Location:** MENU 4B

Functions>Configuration>General Setup>

### Serial command method

**Command:** travel ###

**Arguments:** ### The desired full-stroke rotation in degrees.

## DEMAND CALIBRATION

DCM-2 boards are designed to accept a 4–20 mA (or 1–5 V dc) analog Demand signal. The input comes calibrated from the factory for the full range unless otherwise specified by the customer. It is not necessary to calibrate the Demand input when the actuator is installed; however, if the Demand needs to be calibrated to accommodate unusual operating conditions, two guidelines must be followed: First, the value for 0% must be greater than 0.5 mA and the value for 100% must be less than 21 mA. Second, the difference between 0% and 100% (minimum span) must be at least 4 mA. Use any of the following methods to calibrate Demand. Actuators may also be configured for split-range operation—contact the factory for details.

### Calibrate the 0% and 100% Demand signal:

#### **PUSHBUTTON** method

1. Ensure the Handswitch is in the “STOP” position. This will prevent the drive from repositioning during this procedure.
2. Apply the desired 0% Demand input signal to the actuator (e.g., 4 mA for 4–20 mA signal).
3. Press and hold the “CALIBRATE” pushbutton on the DCM-2 customer interface panel, then press the “SET DEM 0%” pushbutton until the “ACKNOWLEDGE” LED is lit.\*
4. Apply the desired 100% Demand input signal to the actuator (e.g., 20 mA for 4–20 mA signal).
5. Press and hold the “CALIBRATE” pushbutton on the DCM-2 customer interface panel, then press the “SET DEM 100%” pushbutton until the “ACKNOWLEDGE” LED is lit.\*
6. Turn the Handswitch to the “AUTO” position. NOTE: The actuator may reposition.
7. Run the actuator through its full operational range to ensure proper response to the Demand input signal.
9. Replace the compartment covers and tighten the cover bolts to 6 lb-ft (8 N•m) torque.

\*If the “ACKNOWLEDGE” LED does not light, but the “Demand” LED does light, the calibration is out of acceptable range and was not accepted by the DCM-2. This is typically caused by trying to set 0% and 100% values too close together (i.e., less than 4 mA difference).

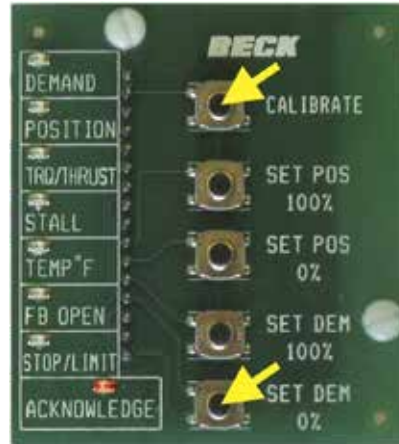

SET  
0%  
DEMAND



SET  
100%  
DEMAND

#### **HART** method

**Command:** DemRngLwr

Enter the desired 0% Demand signal ("4.00" to "16.00" mA).

**Command:** DemRngUp

Enter the desired 100% Demand signal ("8.00" to "20.00" mA).

**DD Menu Location:** MENU 4D

Functions>Configuration>Demand Setup>

#### **Serial** command method

**Command:** dem0pctma ###

**Arguments:** ### Desired 0% Demand signal ("4.00" to "16.00" mA).

**Command:** dem100pctma ###

**Arguments:** ### the desired 100% Demand signal ("8.00" to "20.00" mA).

# CONFIGURATION/CALIBRATION

## LOSS OF DEMAND SIGNAL (LOS)

The DCM-2 is capable of determining if the Demand input signal to the actuator is outside of an acceptable range. The DCM-2 uses a configurable loss of signal (LOS) threshold to determine if the Demand signal falls below a minimum value. Unless otherwise specified in the original order, the factory-set threshold is 3.2 mA. When the DCM-2 senses an LOS condition, an alarm condition will result, illuminating the "Demand" status indication LED. The actuator then responds according to the LOS setting. The DCM-2 can be configured for one of two LOS actions:

1. **Stay in Place**—the actuator output shaft stays in place until the Demand signal returns to the acceptable range. This is the factory default.
2. **Go-to-Position**—the actuator output shaft will move to a preset position, designated in percentage of travel. For example, if the LOS action is set for 50%, the actuator output shaft will drive to the 12 mA position (based on a 4-20 mA span).

The LOS parameters can be configured using HART or Serial commands.



### CAUTION

The following procedures could cause the drive to reposition, which can adversely affect the process and cause potentially dangerous conditions.

### Configure the LOS threshold:

#### HART method

**Command:** DemLimLwr  
Enter "0.00" to "12.00" mA. Decimal value of the lower threshold for detecting LOS. (e.g., the typical value for a 4–20 mA system is "3.20").

**DD Menu Location:** MENU 4D  
Functions>Configuration>Demand Setup>

#### Serial command method

**Command:** demlos ###

**Arguments:** ### Enter the desired Demand signal in mA below which LOS occurs (e.g., the typical value for a 4–20 mA system is "3.20").

### Configure the LOS mode:

#### HART method

**Command:** LOS Mode

**DD Menu Location:** MENU 4D  
Functions>Configuration>Demand Setup>

#### Selections:

**Stay** - select if the actuator should hold output shaft position when a loss of signal occurs.

**Go-to-Pos** - select if the output shaft should go to a specific position when a loss of signal condition occurs. Configure the position with LOS Pos.

#### Serial command method

**Command:** demlos *n*

**Arguments:** *n* Enter the desired mode

**sip:** (drive will stay in place).

**gtp:** (actuator will go to position set in "demlogtp" command)

**pat:** (same as "sip", but suppresses the alarm).

### Configure the LOS position when Go-to-Pos is selected:

#### HART method

**Command:** LOS Pos  
Enter "-5.00%" to "105.00%". The percentage of full travel the actuator will move upon LOS.

**DD Menu Location:** MENU 4D  
Functions>Configuration>Demand Setup>

#### Serial command method

**Command:** demlogtp ##.##

**Arguments:** ##.## Desired position of actuator if "gtp" is selected in "demlos". Position is expressed as a percentage of actuator travel in decimal form (e.g., 50% = "50.00").

## DEMAND CHARACTERIZATION CURVES

The DCM-2 can be configured to interpret the applied Demand signal for linear or non-linear output shaft position response. Three predefined Demand signal response curves are available for use including: Linear, Square, and Square Root. A chart of each of these predefined responses is provided for your reference.

In addition to the three predefined characterizer curves, the DCM-2 also allows a custom user-defined curve to be configured. This option is called "Dem Curve Spcl".

The Demand characterization curve type can be configured with the following methods.

### Change the Demand characterization curve:

#### **HART** method

**Command:** Dem Curve

**DD Menu Location:** MENU 4D

Functions>Configuration>Demand Setup

#### **Selections:**

**Linear** - select if the actual position % should match the applied Demand %.

**Square Root** - select if the actual position % should match the square root of the applied Demand %.\*

**Dem Curve Spcl** - select if a user-defined response is desired (see characterization on the following page to define the desired response curve).

**Square** - select if the actual position % should match the square of the applied Demand %.

#### **Serial** command method

**Command:** demfunc *n*

**Arguments:** *n* Enter the integer that represents the desired Demand signal response as follows:

**0:** Linear - select if the actual position % should match the applied Demand %.

**1:** Square Root - select if the actual position % should match the square root of the applied Demand %.

**4:** Special Curve - select if a user-defined response is desired (see characterization on the following page to set the desired response curve).

**5:** Square - select if the actual position % should match the square of the applied Demand % (e.g., "demfunc 0" sets the drive to a linear Demand response).

## DEMAND SIGNAL RESPONSE CURVES

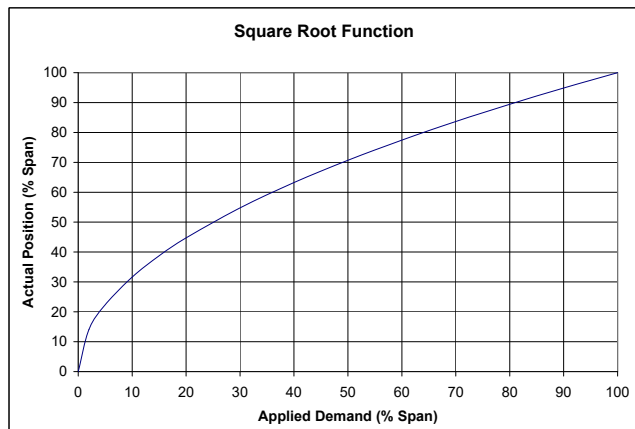
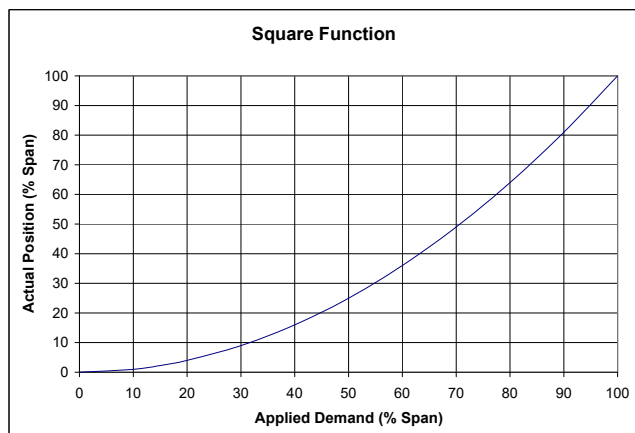
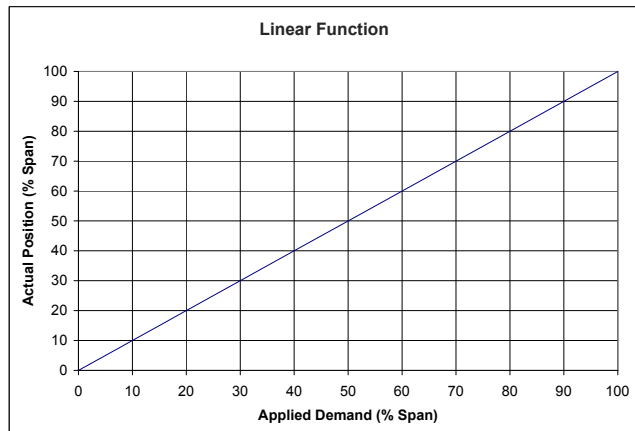

#### **\*NOTE**

**Implementing a square root characterization creates extremely high gain when the Demand signal is below 10%; this causes instability and is unsuitable for control at this level. Do not apply this curve if the control loop may need to modulate at the lower range of travel.**



# CONFIGURATION/CALIBRATION

## USER-DEFINED CHARACTERIZATION

Special curves may be created from up to 20 segments, each of which has a node for a starting point and a node for an ending point. All 20 segments do not have to be used, but the used segments must be grouped together starting with segment 1. Segments cannot be skipped.

A node is a coordinate comprised of an X,Y point. When defining nodes, X-values and Y-values must increase as the node number increases. For example, the X-value and Y-value of node 2 must be higher than the X-value and Y-value of node 1. Nodes cannot be skipped. Always start at node 1.

Unless otherwise specified, the Special curve ships from the factory defined as a linear function (i.e., one segment beginning with node 1 at X = 0%, Y = 0% and ending with node 2 at X = 100%, Y = 100%). X-values are typically chosen to give a reasonable spacing in Y-values.

The customer may specify a custom characterization by entering X- and Y-value pairs to define line segments between 0% and 100%.

For example, the table at right uses 5 segments to approximate the square curve. Segments 1 through 5 are needed, so nodes 1 through 6 are used.

The following methods can be used to configure a user-defined characterization curve.

### Change the user-defined characterization:

#### **HART** method

**Command:** DemNode1X

Enter desired X-value as a percentage for node 1

**Command:** DemNode1Y

Enter desired Y-value as a percentage for node 1

*Repeat above procedures for each node required.*

**DD Menu Location:** MENU 4D

Functions>Configuration>Demand Setup>Dem Curve Spcl

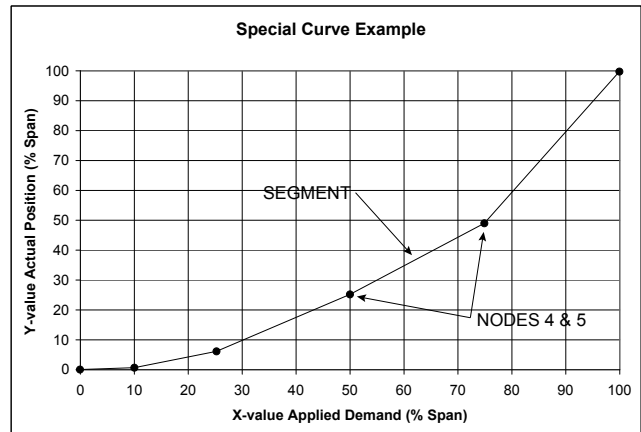

NODE	X-VALUE (DEMAND) % SPAN	Y-VALUE (POSITION) % SPAN
1	0%	0%
2	10%	1%
3	25%	6%
4	50%	25%
5	75%	49%
6	100%	100%

### **Serial** command method

#### Change the user-defined characterization:

**Command:** charset *n1*, *n2*, *n3*

**Arguments:** *n1*, *n2*, *n3*

Where:

*n1* = node number.

*n2* = X-value as a percentage.

*n3* = Y-value as a percentage.

*Values must be separated by commas as shown.*

*Repeat procedure for each node required.*

#### View the user-defined characterization:

**Command:** charlist ###

**Arguments:** ### Enter node number between 1 and 21 or "all".

*Displays defined nodes.*

#### Clear the user-defined characterization:

**Command:** charclear ###

**Arguments:** ### Enter node number between 1 and 21.

*Clears a defined node by setting it to unused.*

*Will also clear any node numerically higher.*

## POSITION FEEDBACK SIGNAL

DCM-2 control electronics provide a 4–20 mA analog output signal that represents the drive output shaft position. The DCM-2 monitors an internal position voltage from the film potentiometer, controls the drive position, and sources a 4–20 mA signal to terminals 25 (–) and 26 (+). The Feedback will correspond with the 0% and 100% output shaft positions, as determined by the position calibration (page 26). **There is no need for separate Feedback calibration.**

The user has the option of enabling or disabling the position Feedback signal. The factory default configuration will have the Feedback enabled. When the Feedback is enabled, but not in use (i.e., not wired to a load) the "STAT" and "FB OPEN" LEDs will illuminate. This status alarm is helpful in alerting the user to open Feedback wiring, but can be a nuisance when the Feedback is purposely disconnected or unused. Disabling the Feedback signal turns off the output and eliminates the status alarm. If HART or Serial communications are not immediately available to disable the Feedback signal, you can apply a 250 ohm load resistor across the Feedback terminals 25 (–) and 26 (+) to simulate a Feedback loop and eliminate the alarm.

If desired, the milliamp position Feedback values for 0% and 100% positions can be configured differently than the respective standard factory calibration of 4 mA and 20 mA. A valid 0% position Feedback signal value can be configured anywhere in a 3–16 mA range, while a 100% signal value can be configured from 7–21 mA. The 100% milliamp value must exceed the 0% value by at least 4 mA.

The factory calibrated relationship between the position Feedback signal and the output shaft position is linear (i.e., 0% to 100% Feedback signal corresponds directly with 0% to 100% shaft position). This relationship is suitable for most applications; however, the Feedback to Demand relationship can be changed to compensate for characterized Demand signals. This relationship is called "Inverse Demand". Configuring this option allows the position Feedback signal to match the uncharacterized Demand signal rather than true output shaft position.

The following example assumes 4–20 mA Demand and position signals. If the Demand is set to a square characterization, then a 12 mA Demand corresponds to 25% position. If the position Feedback curve is set to linear, then Feedback at 25% is 8 mA. For some control systems, having the Demand at 12 mA and the Feedback at 8 mA may cause a deviation alarm. The Feedback curve can be set to "Inverse Demand" so the Demand and Feedback match when the actuator is balanced. In this example, with Feedback set to "Inverse Demand" and the output shaft position at 25%, the Feedback signal would be 12 mA.

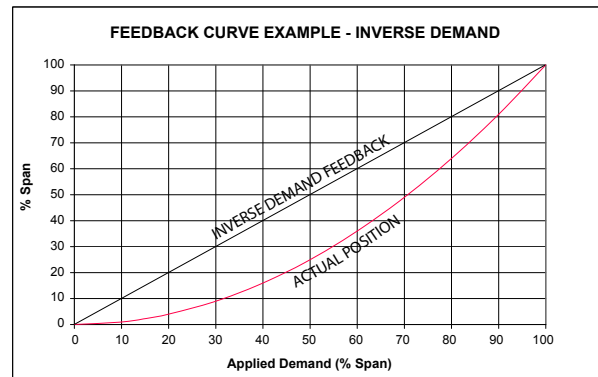
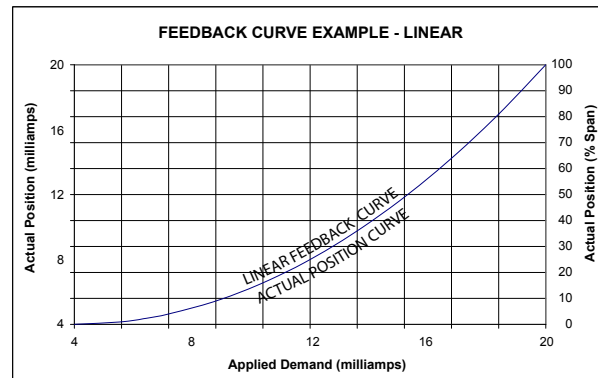

The following methods describe how to enable or disable position Feedback, set the 0% and 100% milliamp values and select the desired Feedback response.

# CONFIGURATION/CALIBRATION

## Enable/disable the position feedback:

### **HART** method

**Command:** Feedback

**DD Menu Location:** MENU 4E

Functions>Configuration>Feedback Setup>

**Selections:**

**Enabled** - to enable position Feedback.

**Disabled** - to disable position Feedback.

### **Serial** command method

**Command:** iomode *n*

**Arguments:** *n*

**0:** Feedback disabled.

**1:** Feedback enabled.

## Set the feedback range lower and upper values:

### **HART** method

**Command:** FB RngLwr

Enter the milliamp value that corresponds with 0% position. Acceptable range "3.00"–"16.00" (typically, "4.00").

**Command:** FB RngUp

Enter the milliamp value that corresponds with 100% position. Acceptable range "7.00"–"21.00" (typically, "20.00").

**DD Menu Location:** MENU 5D

Functions>Configuration>Feedback Setup>

### **Serial** command method

**Command:** fdbk0pctma #.##

**Arguments:** #.## Desired Feedback signal in mA at 0% output shaft position. Minimum value is "3.00".

**Command:** fdbk100pctma #.##

**Arguments:** #.## Desired Feedback signal in mA at 100% output shaft position. Maximum value is "21.00".

## Set the feedback characterization curve:

### **HART** method

**Command:** FB Curve

**DD Menu Location:** MENU 4E

Functions>Configuration>Feedback Setup>

**Selections:**

**Linear** - to enable a linear feedback signal

**InvDem** - to enable an inverted Demand feedback signal.

### **Serial** command method

**Command:** fdbkfunc *n*

**Arguments:** *n*

**0:** Linear Feedback signal.

**1:** Inverse Demand Feedback signal.

## TEMPERATURE SENSING

DCM-2s are equipped with an internal temperature sensing circuit. Real time temperature and historical temperature extremes (low and high) are available.

Temperature units can be selected to be either Fahrenheit or Celsius.

An alarm condition initiates if the actuator's real time temperature falls outside the rating (see "Operating Conditions", page 4). The STAT and TEMP F LEDs will light, but will reset when the temperature is once again within the actuator rating.

## View real time temperature & historical extremes:

### **HART** method

**Command:** Temp

Displays real time temperature as read by the DCM-2.

**DD Menu Location:** MENU 1

**Command:** High Temp

Displays the historical high temperature.

**Command:** Low Temp

Displays the historical low temperature.

**DD Menu Location:** MENU 3D

Functions>Statistics

### **Serial** command method

**Command:** temperature

**Arguments:**

Entered with no argument, displays real time temperature and historical high & low temperatures.

## Set temperature units:

### **HART** method

**Command:** Temperature Unit

**DD Menu Location:** MENU 4B

Functions>Configuration>General Setup

**Selections:** degF - Set the temp. units to Fahrenheit.

degC - Set the temp. units to degrees Celsius.

### **Serial** command method

**Command:** temperature *n*

**Arguments:** *n*

**F:** Set the temp. units to degrees Fahrenheit.

**C:** Set the temp. units to degrees Celsius.



## STALL PROTECTION

The DCM-2 board provides protection for the actuator in the event of a stall. Stall protection is activated when the actuator is unable to achieve the proper position within a defined stall time due to a mechanical impediment or excessive load.

The DCM-2 senses when the motor moves the output shaft in one direction longer than the configured "stall time". The DCM-2 then shuts off power to the motor, preventing further actuator movement. When the stall condition occurs, the STAT LED will illuminate.

Resetting due to a stall condition is achieved by reversing the Demand signal, cycling the actuator power, or submitting a reset command via HART or Serial port.

The stall protection feature can be enabled or disabled and the stall time may be configured between 30 and 450 seconds. This feature is factory enabled and the default setting is 300 seconds. If reconfiguring, it is advisable to configure the stall time with a value greater than the maximum stroke time to avoid false stall protection events and alarms.

### Enable / disable stall protection:

#### **HART** method

**Command:** StallProt

**DD Menu Location:** MENU 4B

Functions>Configuration>General Setup>

**Selections:**

**Enabled** - to enable stall protection.

**Disabled** - to disable stall protection.

#### **Serial** command method

**Command:** stallprot *n*

**Arguments:** *n*

**0:** stall protection disabled.

**1:** stall protection enabled.

### Configure the stall time:

#### **HART** method

**Command:** Stall Time

Enter the stall time in seconds. Valid stall times are 30 to 450 seconds.

**DD Menu Location:** MENU 4B

Functions>Configuration>General Setup>

#### **Serial** command method

**Command:** stalltime ###

**Arguments:** ### Enter the stall time in seconds. Valid stall times are "30" to "450".

### Reset a stall condition:

#### **HART** method

**Command:** Reset Stall

Select to reset a stall condition.

**DD Menu Location:** MENU 7

Functions>Manual Operation>

#### **Serial** command method

**Command:** unSTALL

Enter to reset a stall condition.

# MAINTENANCE

## MOTOR ASSEMBLY

The control motor is not field-repairable. **Do not disassemble the motor.** Disassembly of the motor will result in a loss of torque that can only be restored by returning the motor to the factory for re-magnetizing.

*Motor assembly replacement instructions follow:*



### WARNING

**Disconnect power before proceeding.**

**Before removing the motor assembly, block the crank arm (if applicable) to prevent the crank arm and gear train from moving when the motor is removed.**

### REMOVE THE MOTOR ASSEMBLY:

Disconnect power from the actuator.

Loosen the four captive, socket head cap screws (3/16" hex wrench) holding the motor to the actuator body.

Gently pull the motor straight back from the actuator until it is free from the wire connector.

### INSTALL THE NEW MOTOR ASSEMBLY:

Align the screws on the new motor assembly with the screw holes on the actuator. This will also align the wire plug on the new motor assembly with the connector on the actuator.

Tighten the screws to 6 lb-ft (8 N•m).

CAPTIVEMOTORSCREWS  
(4 PLACES)

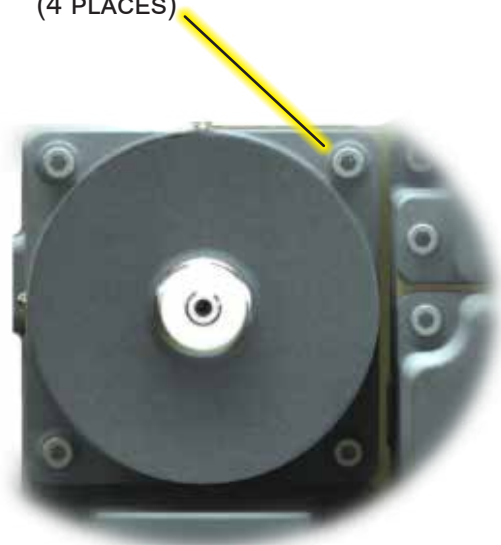

**MOTOR ASSEMBLY**

## LUBRICATION

Periodic lubrication is not required on Beck actuators.

## MOTOR CAPACITOR AND RESISTOR ASSEMBLY

There is no recommended replacement interval for the capacitor and resistor assembly, but they are recommended spare parts. It may be advisable to replace the assembly as a preventative maintenance measure when motors are replaced on older actuators.



### WARNING

**Electrical shock hazard. Disconnect power before proceeding.**

The part numbers and values for each assembly are shown in the “Gaskets, Motors, Resistors & Capacitors” table later in the Maintenance section of this manual. The assembly is located beneath the Handswitch in the Electronic enclosure.

*To replace the capacitor and resistor assembly:*

Disconnect power from the actuator.

Loosen the three captive, socket head cap screws (3/16" hex wrench) holding the electronic enclosure to the actuator body (see image at top right).

Gently pull the enclosure straight back from the actuator until it is free from the wire connector—this will expose the capacitor and resistor compartment (beneath the connector, see image at bottom right).

### REMOVE THE ASSEMBLY:

Cut the capacitor wire and the green connector wire at the wire joint terminal.

Cut the red resistor wire and the red connector wire at the wire joint terminal.

Cut the capacitor cable ties.

Remove the resistor retaining screws and discard the removed capacitor and resistor assembly.

### INSTALL THE NEW ASSEMBLY:

Attach the new resistor using the replacement screws provided (be careful not to pinch any wires).

Attach the capacitor to the brackets (not shown) on the actuator using the two cable ties provided (be careful not to pinch any wires).

Insert the green connector wire and the capacitor wire into a wire joint terminal (provided) and crimp using a crimping tool or pliers.

Insert the red connector wire and the resistor wire into a wire joint terminal (provided) and crimp using a crimping tool or pliers.

Inspect the enclosure gasket for damage and replace, if necessary (see GASKETS later in the Maintenance section of this manual).

Replace the electronic enclosure. Torque the screws to 6 lb-ft (8 N•m).

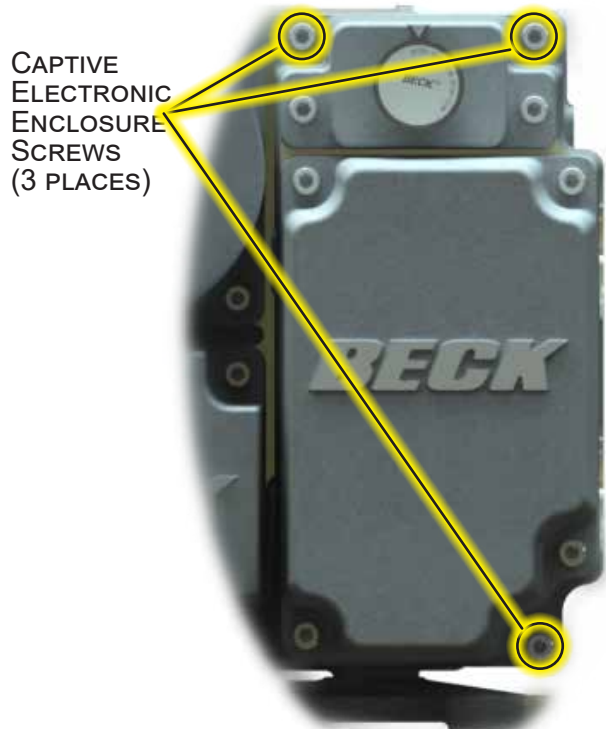

CAPTIVE ELECTRONIC ENCLOSURE SCREWS (3 PLACES)

### ELECTRONIC ENCLOSURE REMOVED TO REVEAL CAPACITOR & RESISTOR COMPARTMENT

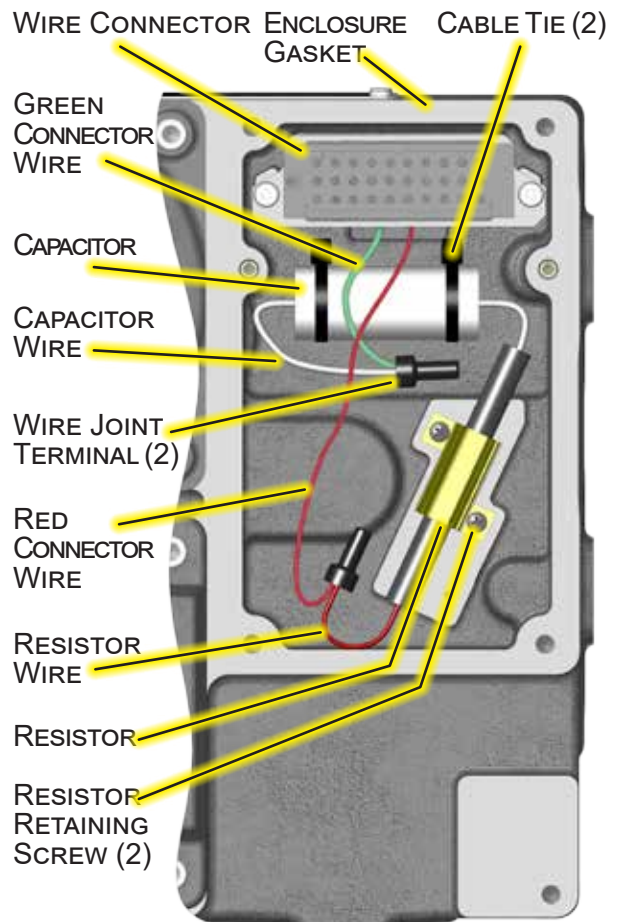

# MAINTENANCE

## SELF LOCKING MECHANISM (SLM)

The Self Locking Mechanism (SLM) is assembled to the front of the motor and couples the motor to the gear train. The primary function of the SLM is to lock the gear train in place when the motor is de-energized. When the motor is energized, the SLM releases and allows the motor to drive the gearing.

There is no recommended maintenance interval for the SLM. The SLM can last for many years in normal service. SLM wear is a function of loading and the number of starts/stops the motor experiences over time. Overloading or stalling the motor will accelerate SLM wear.

Signs of wear include the inability of the actuator to hold position when the motor is de-energized. This could result in constant on-off oscillation. Severe SLM wear or damage may result in a loss of torque at the output shaft.

It is often possible to confirm SLM wear or damage by checking motor operation with the Handwheel. Place the Handswitch in the STOP position, and rotate the motor Handwheel back and forth. There should be free play before the motor pinion/gearing turns (up to one tenth of a full Handwheel rotation). Lack of free play or rough motor movement may indicate the need for SLM reconditioning.

Disassembly and close inspection of the SLM components is required to evaluate its condition.

### SLM REPLACEMENT KIT (P/N 12-8064-23)

Description	Part Number
Gasket, Motor	20-0661-56
Friction Material	13-0080-06
Steel Ball	14-9420-06
Locking Disc	14-9330-40
Spring	14-9980-10
Pinion	14-9940-70
Thrust Washer	14-9400-16
Stop Collar	14-9380-04
Spring Pin	10-7111-06



### WARNING

Electrical shock hazard. Disconnect power before proceeding.



### WARNING

Secure the load on the drive output shaft prior to removing the control motor.

## DISASSEMBLY AND CLEANING

When wear or damage is suspected, disassembly and cleaning may be required to determine the extent of needed repairs. Individual parts may be replaced, with the exception of the drive collar, which is not field replaceable. Refer to the illustration at right.

For SLM disassembly and inspection:

1. Disconnect power from the actuator.
2. Secure the actuator load, and remove the motor assembly (see page 36). Handle the motor with care so as not to damage the rotor shaft.
3. Pushing down firmly on the pinion, measure the gap between the stop collar and the thrust washer. This distance should measure  $0.015'' \pm 0.005''$ . A larger gap indicates worn SLM components.
4. Use a felt tip pen to mark the location of the stop collar on the shaft. Support the end of the rotor shaft to prevent it from bending, and drive the 1/8" spring pin out.
5. Carefully (the assembly is spring loaded), remove the stop collar, thrust washer, pinion, spring, and steel balls (4).
6. Remove the locking disc and (4) steel balls from the drive collar.



### CAUTION

Do not disassemble the motor any further, as it has no other user serviceable parts. Further disassembly will result in demagnetization of the motor and loss of the required torque.

7. Clean grease from the pinion and locking disc for inspection. A small amount of dust residue from the friction material is normal. Clean the drive collar detents with a rag and inspect for wear. Inspect the friction material for excessive wear or damage. If the friction material does not appear to be damaged, clean with alcohol to remove any contaminants.
8. Identify worn parts and replace as needed. Note that deformation of the conical detent sockets is cause for replacement of the pinion and locking disc.

## REPLACEMENT AND REBUILD INSTRUCTIONS

1. If the friction material requires replacement, scrape off the old friction material and clean the bonding surface to ensure flatness for the new friction material. Glue the new friction material in place with Momentive 159 silicone RTV or equivalent, taking care to keep the material flat and clean. Allow 24 hours for the RTV to cure.
2. With the motor shaft pointed up, place a steel ball into each of the drive collar detents. Install the locking disc and place a steel ball into each of the detents on the top of the locking disc.
3. Install the pinion, thrust washer (the white side of the thrust washer should face the pinion) and stop collar. Make sure all steel balls are properly seated in the detents of the drive collar, locking disc, and pinion. Align the stop collar and shaft marks made during disassembly and insert a 1/8" pilot punch through the stop collar hole and into the motor shaft to hold it in place.
4. Pushing down firmly on the pinion, measure the gap between the stop collar and the thrust washer. This distance should measure  $0.015" \pm .005"$ . This space is necessary to ensure proper operation. Add shims as necessary. Install the new 1/8" spring pin while supporting the outboard end of the shaft.
5. Install the spring by slipping it over the pinion flange and twisting it into place.
6. Inspect the motor gasket for damage and replace, if necessary (see page 44).

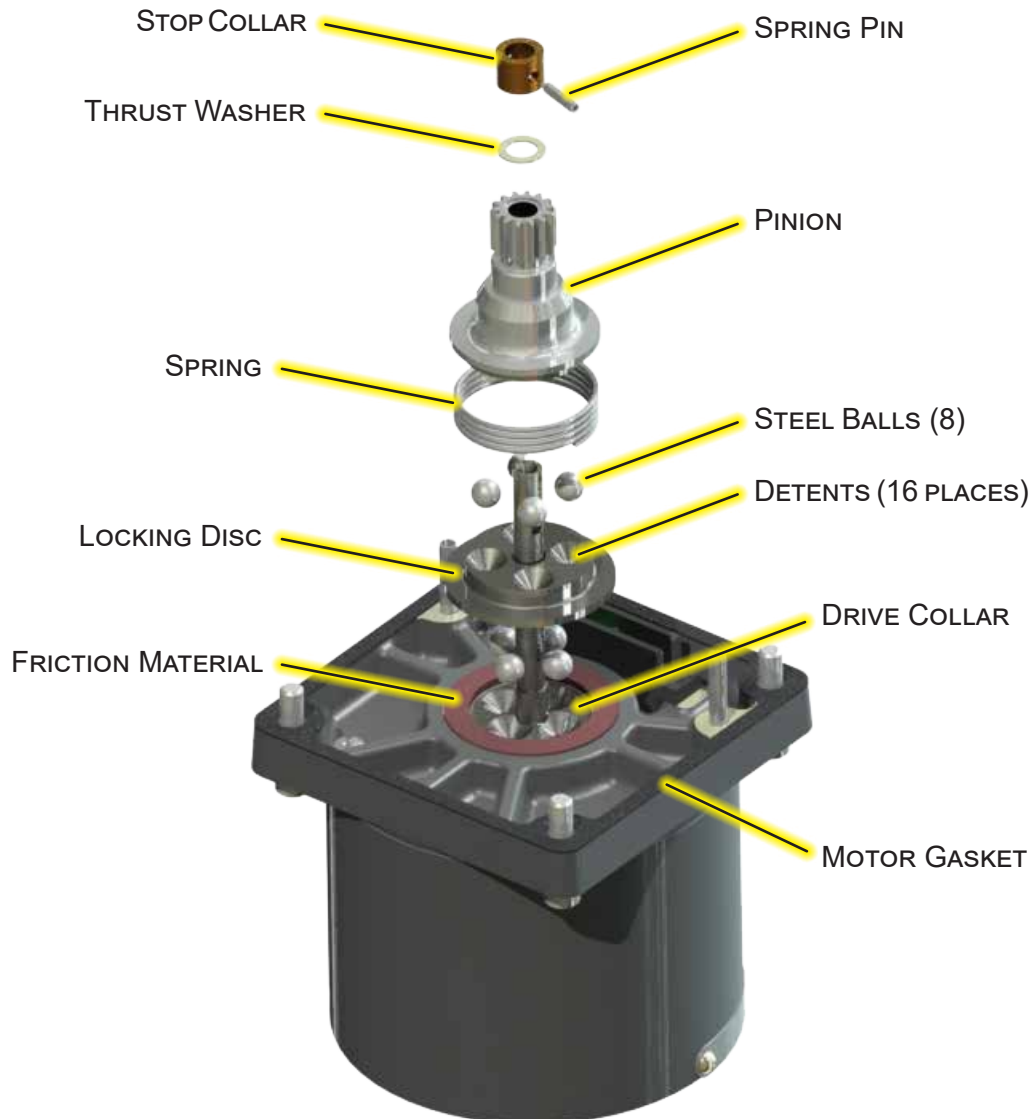

SLM COMPONENTS



# MAINTENANCE

## OVER-TRAVEL LIMIT AND AUXILIARY SWITCHES

Complete switch assemblies may be replaced. It is not possible to replace individual switches. To replace switch assemblies, follow the instructions below.



**WARNING**  
Electrical shock hazard. Disconnect power before proceeding.

Remove the control end cover by loosening the four captive, socket head cap screws (3/16" hex wrench). Remove the screws holding the switch assembly to the switch plate and slide it out to the side.

Transfer the wires to the terminals of the replacement assembly, ensuring the correct wire is transferred to the correct replacement assembly terminal (wires have push-on lugs). Install the replacement assembly and note that it rotates around one screw to permit an adjustment of the cam-to-switch lever spacing and switch operating point. To set the switch, place a .030" (.75 mm) shim between the cam and switch lever (see photo to right). The switch lever should be on the low or minimum radius portion of the cam when setting the switches. Position the switch assembly so that the switch is just actuated. DO NOT overstress the switch lever. Tighten both screws to 10 lb-in (1.1 N•m) torque (using the rectangular washer to cover the gap in the mounting plate) and remove the shim. When properly adjusted, the switch's cam actuated lever will remain in contact with the cam throughout the actuator travel.

## ADDING AUXILIARY SWITCHES

If the actuator has two auxiliary switches, or no auxiliary switches, it is possible to add auxiliary switches in the field. Auxiliary switches are available as an assembly consisting of 2 or 4 switches. A Group 75 actuator may have up to four total auxiliary switches (see below for part numbers).

Install wiring onto the switch push-on lugs and route the wires into the actuator terminal area. Remove the DCM-2 / terminal compartment cover and solder wires to the underside of the terminal board according to the wiring diagram included with the new switch assembly (this will require removal of the DCM-2—see DCM-2 BOARD replacement instructions, next page). Install the new switch assembly and adjust according to the preceding instructions.

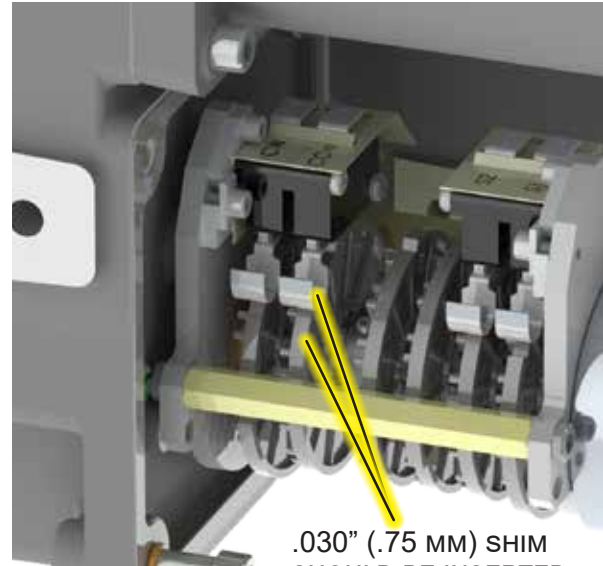

.030" (.75 mm) SHIM SHOULD BE INSERTED BETWEEN ALL LEVERS AND CAMS WHEN SETTING SWITCHES.

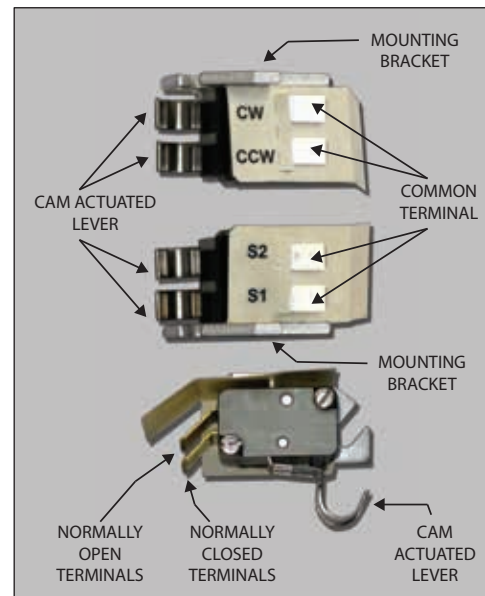

### SWITCH PARTS

Description	Part Number
Over-travel limit switch assembly (CW/CCW)	20-3200-06
Auxiliary limit switch assembly, (2) switches (S1/S2)	12-8064-70
Auxiliary limit switch assembly, (4) switches (S1/S2/S3/S4)	12-8064-71
Limit switch cam assembly	11-0931-11

## DCM-2 BOARD

Field repair of the DCM-2 board is not recommended.



**WARNING**  
**Electrical shock hazard. Disconnect power before proceeding.**

To replace the DCM-2 board, remove the Digital Control Module/Terminal Block compartment cover (four captive, socket head cap screws (3/16" hex wrench)). Disconnect the plug from the wiring connector (see below for location). Loosen the four captive screws holding the board to its mounting pads. Note the DCM bracket on the end of the board. To remove the board, pull the connector away from its receptacle on the mating surface.

To install a DCM-2 board, lightly press the board connector into its receptacle until the DCM bracket is flush with the "L" bracket. Tighten the four captive screws to 8 lb-in (0.9 N•m). Re-connect the plug into the wiring connector. Replace the DCM/Terminal Block compartment cover and tighten the cover screws to 6 lb-ft (8 N•m) of torque.

CAPTIVE DCM/  
 TERMINAL  
 COVER  
 SCREWS  
 (4 PLACES)



DCM  
 BRACKET

CONNECTOR

CAPTIVE DCM  
 SCREWS  
 (4 PLACES)

SERIAL PORT  
 (RS-232 CONNECTOR)

WIRING  
 CONNECTOR



"L" BRACKET

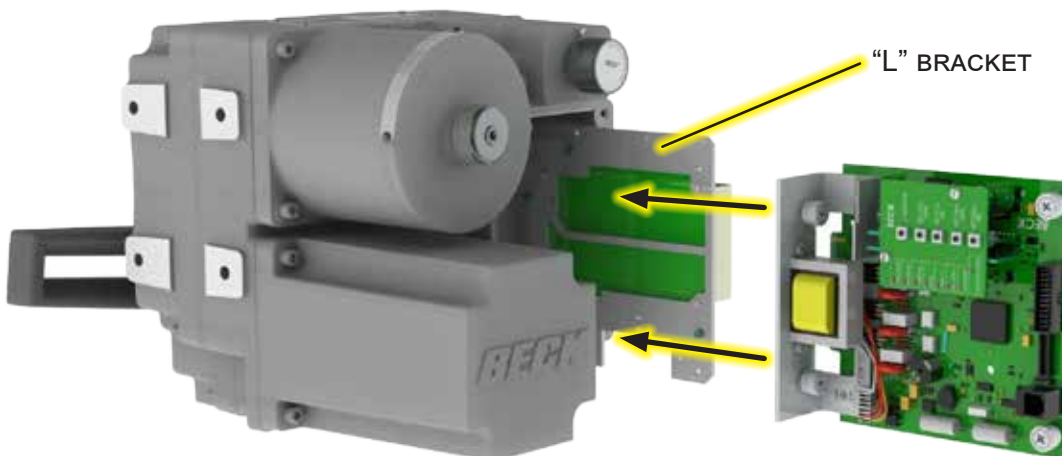

# MAINTENANCE

## TERMINAL BOARD REPLACEMENT

Field repair of the terminal board is not recommended.



### WARNING

Electrical shock hazard. Disconnect power before proceeding.

Refer to the illustrations on pages 39 & 41 for component identification.

Remove the Digital Control Module (DCM)/ Terminal Block compartment cover (four captive, socket head cap screws (3/16" hex wrench)).

The terminal board is attached to an "L" bracket which is mounted to the actuator inside the DCM/Terminal Block compartment. The "L" bracket must be detached from the actuator to allow access to the terminal board mounting screws.

### Remove the DCM

In order to detach the "L" bracket from the actuator, the DCM board (which is also attached to the bracket) must first be removed. Disconnect the plug from the wiring connector. Loosen the four captive screws holding the DCM board to the "L" bracket. Note the location of the DCM bracket and pull the connector away from its receptacle on the mating surface. Set the DCM aside (preferably in an ESD protective bag) for later re-attachment.

### Remove the "L" Bracket

Remove the plugs attached to the 5 connectors on the terminal board (two connectors each on the top & bottom of the board and one connector on the logo side of the board) and note which plug attaches to which connector. Also note the location of any wires attached to the terminals of the terminal board and remove. Remove any wire(s) attached to the grounding screws (green screws) on the terminal board.

Find the location of the three countersunk socket head cap screws attaching the "L" bracket to the actuator (note that these screws are located in the area where the DCM was attached). While supporting the bracket, remove the cap screws and set aside.

### Remove the Terminal Board

Place the "L" bracket on a flat surface with the terminal board side facing up. Remove the four cross recessed screws attaching the terminal board to the bracket. Note the position of the paper shock shield & the paper label with printed terminal numbers. Set aside the paper shield and label for later use.

### Install the new Terminal Board

Align the new terminal board with the appropriate mounting holes on the "L" bracket (as depicted on page 41). Attach the terminal board to the bracket using the four cross recessed screws—ensure that the paper shield and label are positioned properly. Torque the screws to 10 lb-in (1.1 N•m).

### Reattach the "L" Bracket to the Actuator

Align the countersunk screw holes (3) to the mounting holes on the actuator. Tighten the socket head cap screws (removed earlier) to 19 lb-in (2.1 N•m).

### Reattach the DCM to the "L" Bracket

Lightly press the DCM connector into its receptacle (see page 41 for orientation) until the DCM mounting bracket is flush with the "L" bracket.

Align the DCM with the appropriate holes in the "L" bracket and tighten the four captive screws to 8 lb-in (0.9 N•m). Orient the DCM as shown on page 39.

Reconnect the appropriate plug to the wiring connector.

### Reattach the Wiring to the Terminal Board

Attach the plugs to the appropriate connectors (as noted earlier) on the new terminal board. Attach wires (noted earlier) to their proper terminals. Reattach any wire(s) to the grounding screws.

### Replace the DCM/Terminal Block Compartment Cover

Carefully slide the cover over the DCM and terminal board, then attach the cover to the actuator by tightening the four captive, socket head cap screws to 6 lb-ft (8 N•m).



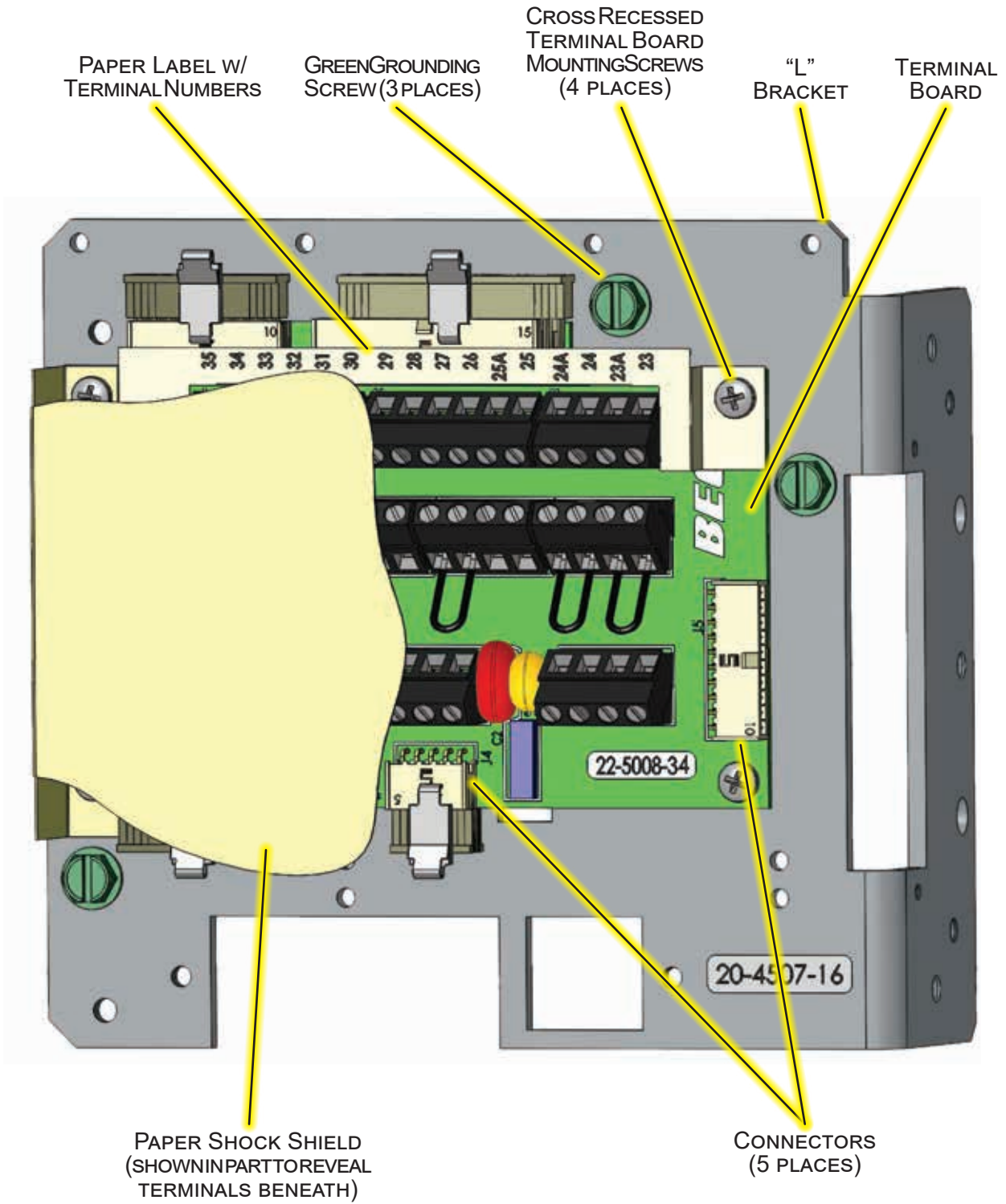

**TERMINAL BOARD AND "L" BRACKET**

# MAINTENANCE

## FILM POTENTIOMETER

Field repair of the Film Potentiometer assembly is not recommended. The factory maintains a stock of replacement assemblies for immediate shipment. Follow the instructions below.



### WARNING

Electrical shock hazard. Operating voltage is supplied across CW and CCW limit switches. Disconnect power before replacing the potentiometer.

### REMOVE THE EXISTING POTENTIOMETER:

1. Remove power from the actuator.
2. Remove the (4) control end cover captive screws (.25-20 x 1.000 socket head cap screws).
3. Carefully cut the cable tie securing the potentiometer wire sleeve (note location of tie).
4. Detach the potentiometer wire plug from the actuator wire plug.
5. Loosen the set screw holding the insulator/wiper assembly to the flat of the control shaft.
6. Pull the insulator/wiper assembly off of the control shaft.
7. Loosen the (4) potentiometer retaining screws (4-40 x .750 socket head) and rotate the silver, rectangular washers so that they are no longer holding the potentiometer in place.
8. Pull the potentiometer off of the control shaft.

### INSTALL THE NEW POTENTIOMETER:

9. Slide the new potentiometer onto the control shaft, ensuring it is flat against the mounting plate with the wire side facing away from the actuator. Orient the potentiometer so that the wire sleeve is at the top of the mounting plate.
10. Rotate the (4) silver, rectangular washers so that they are holding the potentiometer in place. Tighten the (4) potentiometer retaining screws (4-40 x .750 socket head) to 5 lb-in.



### CAUTION

To prevent damage to the potentiometer, do not allow the washers to touch the wire contact surfaces.

11. Carefully slide the insulator/wiper assembly onto the control shaft, ensuring that the wipers face the potentiometer and that the set screw on the collar is on the flat of the control shaft. Gently push the insulator/wiper assembly until it is flat against the potentiometer—being careful not to pinch any wires.



### CAUTION

To avoid damage, do not touch the wipers on the back of the insulator/wiper assembly.

12. Tighten the set screw to 2 lb-in.
13. Connect the potentiometer wire plug to the actuator wire plug.
14. Using a cable tie, secure the potentiometer wire sleeve in the same manner as noted in Step 3.

### CALIBRATE THE POTENTIOMETER:

15. Apply power to the actuator. Do not touch the power terminals or any switches.
16. Remove the (4) terminal/electronic compartment cover captive screws (.25-20 x 1.000 socket head cap screws).
17. Ensure that the actuator is at the approximate midpoint of travel between the hard (mechanical) stops. The flat of the control shaft should be level with the top of the actuator.
18. Connect a voltmeter between test points TP1 & TP4 on the Digital Control Module (DCM-2).
19. Loosen the (4) potentiometer retaining screws (4-40 x .750 socket head) and rotate the silver, rectangular washers so that they are no longer holding the potentiometer in place.
20. Gently rotate the potentiometer until the meter shows a reading of 2.87 V.
21. Rotate the (4) silver, rectangular washers so that they are once again holding the potentiometer in place. Tighten the (4) potentiometer retaining screws (4-40 x .750 socket head cap screws) to 5 lb-in.
22. Ensure proper operation.
23. Disconnect meter.
24. Reinstall the control end and terminal/electronic compartment covers. Tighten cover screws to 6 lb-ft (8 N•m).

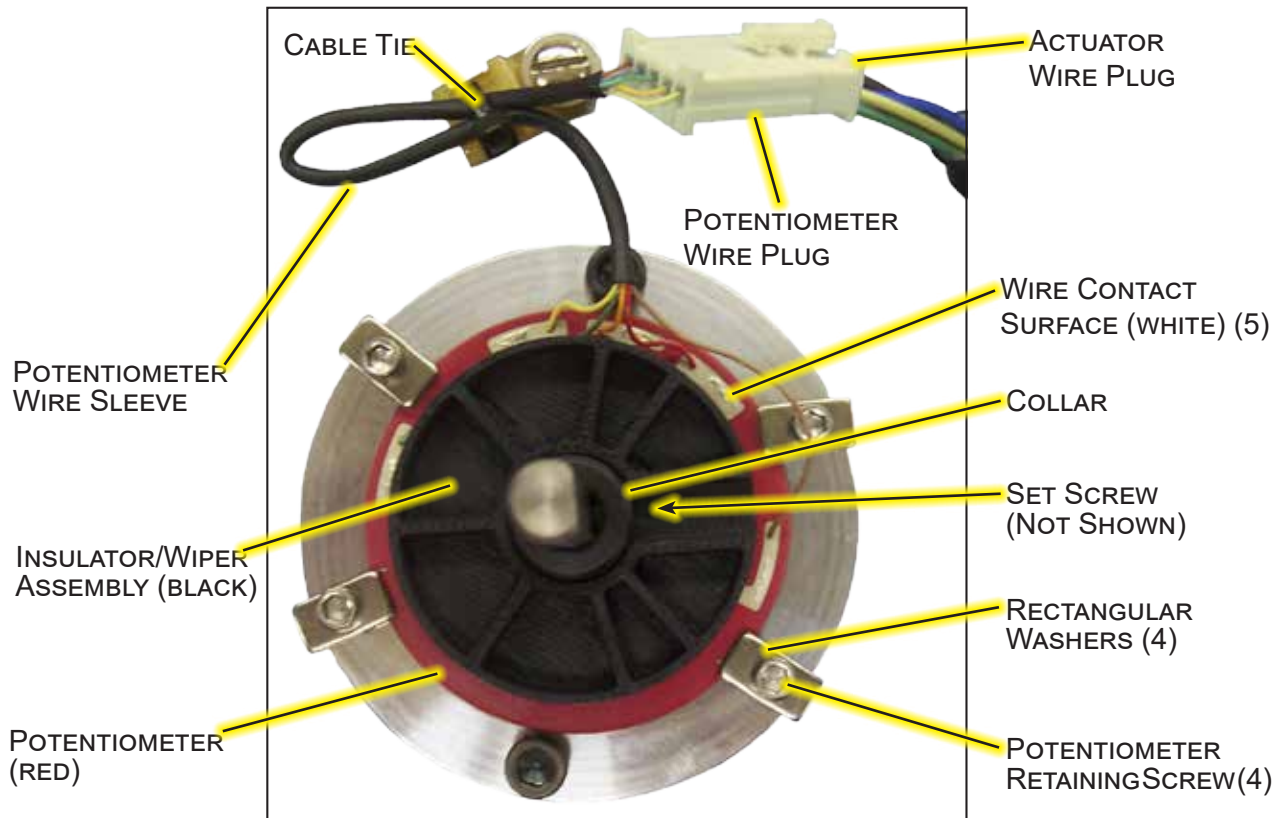
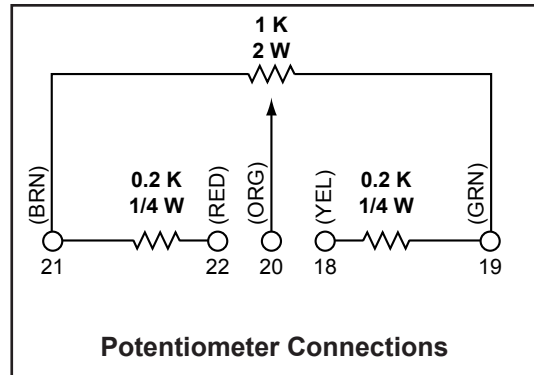

**FILM POTENTIOMETER COMPONENTS**

# MAINTENANCE

## HANDSWITCH



### WARNING

Electrical shock hazard. Disconnect power before proceeding.

#### REMOVE THE EXISTING HANDSWITCH:

1. Remove power from the actuator.
2. Loosen the two socket head cap screws (3/16" hex wrench) on the Handswitch cover. Gently pull the cover and Handswitch assembly away from the actuator until the Handswitch wires are exposed.
3. Clip the five wires from the old Handswitch (removing any tie wraps or sleeving that may interfere).
4. Remove the Handswitch knob by loosening the two inset screws (5/64" hex wrench).
5. Remove the threaded bushing behind the Handswitch knob. The remaining Handswitch assembly components may now be removed from the Handswitch cover.



HANDSWITCH COVER  
SCREWS (2 PLACES)

#### INSTALL THE NEW HANDSWITCH:

6. Insert the new threaded bushing through the Handswitch cover onto the shaft, then attach the components leading to the switch as shown in the illustration below.
7. Place the seal in the bushing, then insert the knob over the bushing. Tighten the two inset screws to 3 lb-ft (4 N•m).
8. Splice the wires from the new Handswitch assembly to the wires from the actuator, color to color. Ensure the wiring is not exposed after splicing.
9. Replace the Handswitch cover, tightening the screws to 6 lb-ft (8 N•m).

**NOTE: When the Handswitch is turned fully clockwise, "AUTO" should be indicated. Be sure to place the tab on the tabbed washer into the slot in the actuator body to secure the Handswitch in place.**

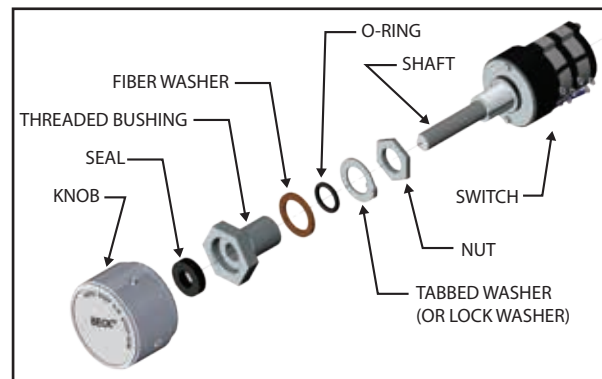

HANDSWITCH COMPONENTS

## GASKETS

While performing any maintenance, inspect exposed gaskets for wear or damage. In order to protect internal components, worn or damaged gaskets should be replaced.

To remove existing gaskets, scrape all of the old gasket material and adhesive residue from the cover and actuator mating surface.

Standard Group 75 models are manufactured with self-adhering, silicone rubber gaskets. Peel the backing off of the replacement gasket and carefully apply to the actuator body.

## RECOMMENDED SPARE PARTS

A table of common, recommended spare parts is shown below:

<i>Description</i>	<i>Part Number</i>
DCM-2 Board	22-5012-59
Fuse, 7A, 125V (For use on DCM-2)	11-1373-01
DCM-2 Serial Cable Kit	20-0511-13
Film Potentiometer Assembly	20-3060-11
Overtravel limit switch assembly (CW / CCW)	20-3200-06
Auxiliary switch assembly 2 switches (S1-S2) 4 switches (S1-S4)	12-8064-70 12-8064-71
Motor Assembly, Capacitor / Resistor Assembly	See Table Below
Gasket Replacement Kit	12-8064-24

If assistance is required in determining the spare part(s) needed, please contact Beck.

## MOTORS & CAPACITOR/RESISTOR ASSEMBLIES

<i>Motor</i>						<i>Capacitor / Resistor Assembly Part Number</i>	<i>Capacitor Value (<math>\mu</math>f)</i>	<i>Resistor Value (<math>\Omega</math>)</i>
<i>Part Number</i>	<i>Current (Amps)</i>	<i>RPM</i>	<i>Frequency (Hertz)</i>	<i>Torque lb-ft [N·m]</i>	<i>Timing (sec./100°)</i>			
<b>NORMAL TEMPERATURE ACTUATOR MODELS</b>								
20-2700-41	.17	72	60	40 [54]	40	14-2842-31	2	500
	.20	60	50		48	14-2842-30	3	500
20-2701-41	.31	72	60	80 [108]	40	14-2842-33	4	475
	.37	60	50		48	14-2842-32	6	360
20-2701-72	.45	120	60	80 [108]	24	14-2842-35	5	220
	.54	100	50		28.8	14-2842-34	6	220
<b>OPTIONAL HIGH TEMPERATURE ACTUATOR MODELS</b>								
20-2700-40	.17	72	60	40 [54]	40	14-2842-41	2	500
	.20	60	50		48	14-2842-40	3	500
20-2701-40	.31	72	60	80 [108]	40	14-2842-43	4	475
	.37	60	50		48	14-2842-42	6	360
20-2701-71	.45	120	60	80 [108]	24	14-2842-45	5	220
	.54	100	50		28.8	14-2842-44	6	220

NOTE: All motors listed are rated at 120 V ac.



# TROUBLESHOOTING

The DCM-2 features diagnostics to help troubleshoot problems.

The following list provides a systematic method for isolating any actuator problems.

1. Operating Voltage
2. Handswitch
3. DCM-2 Status Indication LEDs
4. DCM-2 Testpoints
5. DCM-2 Configuration
6. Shaft Position
7. Inhibitors / Statistics

## OPERATING VOLTAGE

To check the input power supply, view the Status Overview LEDs on the DCM-2 board (see illustration on page 20). Access the DCM-2 by removing the DCM/Terminal Block compartment cover (see page 43 for location).

The PWR LED should pulse from dim to bright, which indicates that power is applied to the actuator and the DCM-2 has successfully completed (continuous) self-tests. If the PWR LED is not lit or pulsing, there may be a problem with the AC power supply to the actuator.

Ensure the actuator is receiving 120V (+10% to -15%). To check the voltage, locate the power terminals on the terminal block (see wiring diagram on the underside of the electrical warning shield). Using a voltmeter, measure the voltage applied to those terminals. If the voltage is correct, additional troubleshooting is necessary to determine the problem; if the voltage is not correct, apply the proper power.

## HANDSWITCH OPERATION

Verify proper operation of the Handswitch, which bypasses the actuator control electronics and switches power directly to the motor windings. Operate the actuator in both directions of travel using the Handswitch. If the drive responds as expected, electro-mechanical problems with the motor and gearing may be eliminated. The trouble may lie with the electronics.

## DCM-2 STATUS INDICATION LEDES

The DCM-2 has seven Status Indication LEDs that provide specific information about the actuator's state (page 21). A lit LED indicates that a condition exists.

## DCM-2 TESTPOINTS

The DCM-2 controls actuator output position by comparing the actuator's Demand input signal with the internal Position feedback signal from the potentiometer. The integrity of these signals is critical to actuator performance. The signals should be verified whenever there are possible actuator problems. There are four test points provided on the DCM-2 board (see illustration on page 20 for locations) that are used to measure the Demand input and internal Position signals directly at the DCM-2.

Measure the Demand signal voltage across TP2(+) and TP3(-). A typical 4–20 mA input signal will measure a proportional 1–5 Vdc across the test points. It is important to verify that the measured voltage corresponds correctly to the signal that is being applied. If there is a mismatch, further troubleshooting is required.

The Position signal to the DCM-2 is generated by the actuator's film potentiometer. The potentiometer is designed to provide a 1–5 Vdc signal to the DCM-2 corresponding to 100 degrees of actuator output shaft rotation. The Position signal can be determined at the DCM-2 by measuring the voltage across TP4(+) and TP1(-). Verify that this signal matches Demand and the position of the output shaft.

Both the Demand and Position signals can also be checked at the appropriate terminals in the terminal block, via HART communications or through the Serial port. All values should agree with test point values. Any differences will require further troubleshooting.

## DCM-2 CONFIGURATION

The DCM-2 can be configured for several operational modes as shown in HART menu 3E or Serial command "opmode".

The factory configuration is the "Follow" mode which allows the actuator to operate with a 4-20 mA control signal when the Handswitch is set to AUTO.

The "Hold" mode causes positioning according to the HART Interface Demand Value (HART menu 3E).

The "Stay" mode causes the output shaft to remain stationary and maintain its present position. In "Stay" mode, the Handwheel cannot be freely turned as it will move back to the position where the "Stay" mode was activated.

The "Stop" mode removes power from the motor. In "Stop" mode the Handwheel can be freely turned. All operating modes can be overridden by the drive Handswitch. If the operation mode is (inadvertently) switched to a mode other than "Follow" there will not be an outward indicator.

**Note that resetting the DCM-2 to factory settings does not change the operational mode back to "Follow" for safety purposes.**

### **SHAFT POSITION**

The output shaft position can be read using HART (menu 1). It can also be determined by running the Serial command "stat".

If the percentage displayed in the Position value does not appear to match the percentage of physical output shaft position, a film potentiometer adjustment may be required. Follow these directions to correct positioning (see page 43 for component identification):

1. Ensure that the actuator is at the approximate midpoint of travel between the hard (mechanical) stops. The flat of the control shaft should be level with the top of the actuator.
2. Connect a voltmeter between test points TP1 & TP4 on the Digital Control Module (DCM-2).
3. Loosen the (4) potentiometer retaining screws (4-40 x .750 socket head) and rotate the silver, rectangular washers so that they no longer hold the potentiometer in place.
4. Gently rotate the potentiometer until the meter shows a reading of 2.87 V.
5. Rotate the silver, rectangular washers so that they are once again holding the potentiometer in place. Tighten the (4) potentiometer retaining screws to 5 lb-in (.56 N•m).

Verify proper operation.

### **INHIBITORS / STATISTICS**

Conditions that prevent the actuator from moving are called inhibitors. HART MENUS 5F and 5G list the CW and CCW inhibitors respectively (see the Hart Communication Appendix). Inhibitors may also be reviewed by running the Serial command "stat" (see the Serial Commands Appendix). The following list indicates why the inhibitor would be in the ON state.

#### **Balance**

Demand and position are balanced.

#### **Supervisory**

DCM-2 is initializing (or malfunctioning).

#### **Stall**

A stall condition has been detected.

#### **OverTrq/Thr**

Not applicable for Group 75 actuators.

#### **Switch Block**

The Handswitch, override or a limit switch is inhibiting movement.

#### **Bad Pos Sig**

The position signal is out of range.

#### **Bad Dem Sig**

The Demand signal is out of range.

#### **Local Cal**

The calibrate button is being pressed on the local pushbutton panel.

The factory can assist with troubleshooting—please provide the results of the above review to expedite assistance.

# TROUBLESHOOTING

CONDITIONS	POSSIBLE CAUSES	CORRECTIONS
1. No DCM-2 LEDs are illuminated.	<ul style="list-style-type: none"> <li>a. No power is applied to the actuator.</li> <li>b. Incorrect power is applied to the actuator.</li> <li>c. Main power fuse/breaker is blown.</li> <li>d. DCM-2 malfunction.</li> </ul>	<ul style="list-style-type: none"> <li>a. Apply operating voltage to the operating voltage terminals.</li> <li>b. Verify correct voltage on actuator nameplate and ensure that it is applied at the operating voltage terminals.</li> <li>c. Verify fuse/breaker integrity. Replace/reset if blown. Find cause of the short circuit.</li> <li>d. Replace DCM-2.</li> </ul>
2. STAT LED is illuminated.	<ul style="list-style-type: none"> <li>a. A status alarm is active.</li> </ul>	<ul style="list-style-type: none"> <li>a. Check the status indication LEDs on the local pushbutton interface of the DCM-2. Continue troubleshooting based on the LEDs that are illuminated.</li> </ul>
3. Demand LED is illuminated.	<ul style="list-style-type: none"> <li>a. No Demand signal.</li> <li>b. Applied Demand signal is outside of configured range.</li> <li>c. Polarity of applied signal wires is reversed.</li> </ul>	<ul style="list-style-type: none"> <li>a. Apply a Demand signal to terminals 24 (+) &amp; 23 (-).</li> <li>b. Confirm Demand signal value via HART or by measuring DC voltage across DCM-2 test points TP3(+) &amp; TP2(-). Should be 1–5 volts for 4–20 mA applied signal.</li> <li>c. Correct the polarity of the applied control signal wires on terminals 24 (+) &amp; 23 (-).</li> </ul>
4. POSITION LED is illuminated.	<ul style="list-style-type: none"> <li>a. Position signal voltage generated by Film Potentiometer read by the DCM-2 is outside of the configured range.</li> <li>b. Film Potentiometer malfunction.</li> <li>c. DCM-2 malfunction.</li> </ul>	<ul style="list-style-type: none"> <li>a. Using HART communicator check the Position Sensor Setup menu to verify the voltage falls within the configured range (typical range 1 to 5 volts); OR measure DC volts between DCM-2 test points TP4 (+) and TP1 (-) to verify voltage. If the voltage is outside of 1 to 5 volts, recalibrate or replace the Film Potentiometer.</li> <li>b. Replace Film Potentiometer.</li> <li>c. Replace DCM-2.</li> </ul>
5. STALL LED is illuminated.	<ul style="list-style-type: none"> <li>a. Actuator has stalled—unable to achieve desired position within the configured stall time.</li> <li>b. The configured stall time is less than the configured Max Travel Time.</li> </ul>	<ul style="list-style-type: none"> <li>a. Eliminate the obstruction and reset the stall by reversing direction on your Demand signal, cycling the power, or issuing the stall reset from HART or Serial command.</li> <li>b. Configure the stall time to exceed the Max Travel Time via HART or Serial command.</li> </ul>
6. TEMP F LED is illuminated.	<ul style="list-style-type: none"> <li>a. The measured temperature at the DCM-2 is outside of the normal operating range of -40° to 185° Fahrenheit.</li> </ul>	<ul style="list-style-type: none"> <li>a. Protect the actuator from the extreme temperatures below or above the operating range to eliminate the alarm.</li> </ul>
7. FB OPEN LED is illuminated.	<ul style="list-style-type: none"> <li>a. The position Feedback circuit current loop is not complete.</li> <li>b. The position Feedback is enabled, but not in use.</li> </ul>	<ul style="list-style-type: none"> <li>a. Ensure the device measuring the 4-20 mA Feedback is properly terminated on terminals 25 (-) and 26 (+) and is applying a 0–800 ohm load resistance.</li> <li>b. Disable Feedback via HART or Serial command; OR terminate the Feedback loop by applying a 0–800 ohm load resistance across terminals 25 and 26.</li> </ul>

CONDITIONS	POSSIBLE CAUSES	CORRECTIONS
8. STOP/LIMIT LED is illuminated.	<ul style="list-style-type: none"> <li>a. The applied power is below the tolerance (-15%) of the nameplate operating voltage.</li> <li>b. A DCM-2 fuse is open.</li> <li>c. A component failure has occurred on the DCM-2.</li> <li>d. The Handswitch is in STOP.</li> <li>e. The actuator has traveled to an over-travel limit switch.</li> <li>f. The actuator is not at an over-travel limit switch, but the limit switch is open.</li> </ul>	<ul style="list-style-type: none"> <li>a. Apply the correct operating voltage to the actuator per the voltage stamped on the nameplate.</li> <li>b. Replace the open fuse.</li> <li>c. Replace the DCM-2.</li> <li>d. Place the Handswitch in AUTO.</li> <li>e. Verify if the limit switch is set outside of the electrically calibrated limits. Readjust, if necessary, or replace.</li> <li>f. Replace the over-travel limit switch (CW/CCW) assembly.</li> </ul>
9. Power LED is pulsing bright to dim.	<ul style="list-style-type: none"> <li>a. This indicates normal function.</li> </ul>	<ul style="list-style-type: none"> <li>a. No action required.</li> </ul>
10. All LEDs are illuminated or flashing.	<ul style="list-style-type: none"> <li>a. A component failure has occurred on the DCM-2.</li> </ul>	<ul style="list-style-type: none"> <li>a. Replace the DCM-2.</li> </ul>
11. REV LED is illuminated, actuator is not moving, and there are no other status alarms.	<ul style="list-style-type: none"> <li>a. Operation mode is set to "STOP".</li> </ul>	<ul style="list-style-type: none"> <li>a. Using HART (operation mode menu) OR using Serial command "opmode", change operation mode to "Follow".</li> </ul>
12. Actuator will not hold position with Handswitch in STOP.	<ul style="list-style-type: none"> <li>a. Self Locking Mechanism (SLM) is worn or damaged.</li> </ul>	<ul style="list-style-type: none"> <li>a. Rebuild the SLM assembly.</li> </ul>
13. Motor runs, but the output shaft does not move in one or both directions.	<ul style="list-style-type: none"> <li>a. Self Locking Mechanism (SLM) has failed.</li> </ul>	<ul style="list-style-type: none"> <li>a. Rebuild the SLM assembly.</li> </ul>
14. PWR LED is flashing, no status LED's are lit and does not respond to Demand signal or Handswitch.	<ul style="list-style-type: none"> <li>a. The Handswitch is damaged.</li> <li>b. The Handswitch jumper between terminal 1B and 11 is missing or faulty.</li> </ul>	<ul style="list-style-type: none"> <li>a. Check continuity from terminals 16 to 4 and 12 to 3 with Handswitch in AUTO position. If either does not show continuity, replace Handswitch.</li> <li>b. Install a wire jumper between terminals 1B and 11.</li> </ul>
15. PWR LED is flashing, no status LED's are lit, actuator functions with the Handswitch, but does not respond to Demand signal.	<ul style="list-style-type: none"> <li>a. A jumper has been installed in the 24-pin connector (J2) of the DCM-2 board.</li> </ul>	<ul style="list-style-type: none"> <li>a. Remove any jumpers from the J2 connector on the DCM-2.</li> </ul>
16. HART communications cannot be established with the DCM-2.	<ul style="list-style-type: none"> <li>a. The device description (DD) file is not installed.</li> <li>b. The HART communicator is not compatible with Beck equipment.</li> <li>c. The HART communications circuit on the DCM-2 is damaged.</li> </ul>	<ul style="list-style-type: none"> <li>a. Install the Beck MK-2 DD on your HART device.</li> <li>b. Utilize a compatible HART communicator or configure the actuator through the Serial port.</li> <li>c. Replace the DCM-2.</li> </ul>
17. Position voltage on DCM-2 testpoints TP4 and TP1 is within 1-5 volts DC following the actuator position, but the position Feedback signal at terminals 25 and 26 remains constant or is erratic.	<ul style="list-style-type: none"> <li>a. The position Feedback circuit on the DCM-2 is damaged.</li> </ul>	<ul style="list-style-type: none"> <li>a. Replace the DCM-2.</li> </ul>

# TROUBLESHOOTING

CONDITIONS	POSSIBLE CAUSES	CORRECTIONS
18. Output shaft rotates opposite of desired direction when applying a 4–20 mA Demand signal.	a. The rotation direction is incorrectly configured.	a. Configure the rotation direction using pushbutton, HART, or Serial method.
19. Motor erratic or runs in wrong direction in AUTO or using Handswitch.	a. Motor winding is open. b. Motor capacitor is shorted or open. c. Motor resistor is open.	a. Replace motor assembly. b. Replace capacitor. c. Replace resistor assembly.
20. Actuator does not follow input signal until maximum or minimum is reached, then drives uncontrollably to limit.	a. Wire jumpers on terminals 12 and 16 are reversed. b. Film Potentiometer out of calibration.	a. Connect terminal jumpers from 12 to 13 and from 16 to 15. b. Recalibrate the Film Potentiometer.
21. Actuator oscillates in AUTO mode.	a. Excessive noise on the input signal. b. Physical obstruction causing a stall condition (e.g., valve jammed or load greatly exceeds actuator rating.) c. The DCM-2 is malfunctioning. d. Excessive wear in the gear train or bearings. e. Film Potentiometer Failure. f. Self Locking Mechanism (SLM) is worn or damaged.	a. Eliminate noise or increase actuator step size. b. Check operation with Handswitch and remove obstruction if present. Handswitch bypasses the DCM-2 board. c. Replace the DCM-2 board. d. Replace worn actuator parts. e. Replace the Film Potentiometer. f. Rebuild the SLM.
22. Actuator will not run in either direction or one direction in AUTO or using Handswitch.	a. Over-travel limit switch failure. b. Handswitch failure.	a. Replace over-travel limit switch assembly (CW/CCW). b. Replace Handswitch assembly.
23. Actuator does not stop at normal or desired limit of shaft travel.	a. DCM-2 position calibrated incorrectly. b. Limit switches set incorrectly. c. Over-travel limit switch failure.	a. Calibrate DCM-2 0% and 100% positions. b. Readjust the limit switches. c. Replace the over-travel limit switch assembly (CW/CCW).
24. Position Feedback signal does not reach maximum signal, but low end calibration is correct.	a. Feedback loop is overloaded.	a. Make sure that the load resistance is between 0 and 800 ohms total across terminals 25 and 26.
25. Actuator runs uncontrolled to one end of travel.	a. Handswitch Failure. b. The DCM-2 is malfunctioning. c. The Film Potentiometer is malfunctioning. d. Terminal block jumpers 15 to 16 and 13 to 12 not connected. e. The actuator has detected a loss of Demand signal (LOS) and is configured for GTP 0% or 100%. f. Handswitch in CW or CCW position.	a. Check continuity from terminals 11–4 and 11–3 with Handswitch in AUTO and actuator power disconnected. If either shows continuity, replace Handswitch. b. Verify Film Pot. voltage signal at DCM-2 test points TP4 and TP1 for 1–5 volts DC corresponding with output shaft position. If signal is valid, replace DCM-2. c. Verify Film Pot. wire connections, check voltage at DCM-2 test points TP4 and TP1 for 1–5 volts DC corresponding with output shaft position. Replace Film Pot. if voltage does not change with position. d. Install jumpers. e. See troubleshooting condition no. 3 (Demand LED is illuminated). f. Return Handswitch to AUTO position.





# APPENDIX HART® COMMUNICATION

The DCM-2 board is the control center of the actuator—configuration and calibration are accessed and set through the DCM-2 board. Using the HART interface requires a HART compatible communicator or any device, computer or controller capable of communicating with HART devices and supporting the Beck DCM-2 device description.

## HART® INTERFACE

The interface menu tree for communicating with a DCM-2 using the BECK-MK2 Device Description is located on the previous page. This menu tree summarizes possible setup options, features and available information.

## HART® COMMUNICATORS FOR BECK-MK2

The BECK-MK2 Device Description requires a HART Communicator that is HART 5 capable and has the ability to import Device Description Language Files (DDL) that are certified by the HART Communications Foundation.

## USING THE 275, 375 OR 475 HART® COMMUNICATOR

The HART Communicator leads should be connected in parallel with the analog Demand signal wiring. This allows the communicator to simultaneously communicate over the analog input wires. This does not disturb the analog Demand signal, or disrupt the DCM-2 functions. However, any program changes to the DCM-2 will momentarily suspend the operation of the board (maintains last state) while the change is implemented. Typically, this is only for a second or two.

With the communicator connected in parallel anywhere across the analog Demand wires (see illustration below), it is ready to communicate. Turn on the communicator and wait for communications to be established. When communications are established, the “Online” display will appear. If the drive is multidropped with other devices on a HART network, the first display screen will list all devices and require a selection before the “Online” display is shown. Follow the HART DD menu on the previous page to navigate.

**NOTE: If the communicator is unable to communicate with the DCM-2, it displays the message, “No Device Found”. If this occurs, check to make sure the leads are securely connected to the Demand wiring and retry. If communications still do not occur, the communicator polling setup may be improperly set. Check the “utility” menu and make sure communications polling is set to “always poll”.**

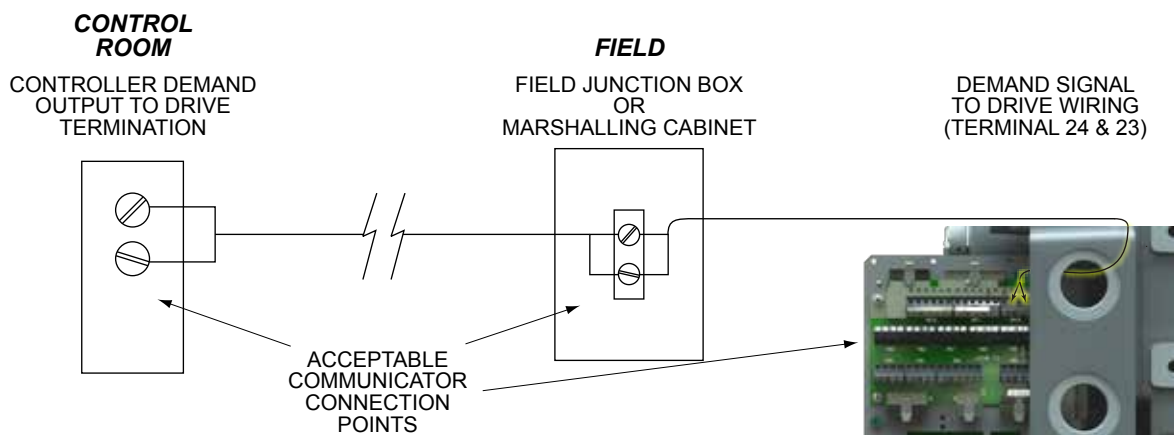

## MENU DESCRIPTIONS (Refer to the HART Device Description Menu)

### MENU 1 -- Online

When communications are established with the communicator, the Online menu is displayed.

- 1 Functions:** The link to the menu tree.
- 2 Position:** The output shaft position displayed as a percent of range.
- 3 Demand:** The Demand signal displayed as a percent of range.
- 4 Loop (Dem):** The Demand signal measured in mA.
- 5 Trq/Thrust:** N/A.
- 6 Temp:** The ambient temperature of the DCM-2.
- 7 Feedback:** The milliamp output signal representing the present position of the output shaft.

### MENU 2 -- Functions

From the Functions menu, any of the DCM-2 functional menus can be selected and accessed. There are seven functional areas: Setup Checklist, Device Information, Configuration, Statistics, Manual Operation, Diagnostics, and Calibration Trim.

### MENU 3A -- Setup Checklist

The Setup Checklist provides a quick way for the user to setup the most important items necessary for basic drive operation without having to move through multiple sub-menus. These items are defined on the following pages in their specific menu locations.

### MENU 3B -- Device Information

The Device Information menu provides information about the actuator. There are ten useful information entries that may be viewed and/or edited.

- 1 Tag:** An 8 character entry that can be used to identify a specific field device label.
- 2 Descriptor:** A 16 character field that can be used to provide any description desired.
- 3 Message:** A 32 character field that can be used to provide any message desired.

**4 Model#:** Displays the model number of the drive in which the DCM-2 is installed. This field may be edited. Note that changing this field may cause the "Use Default Setup" command to not function.

**5 Drive S/N:** The Serial number as shown on the actuator nameplate.

**6 Instld:** Installation date of the actuator or DCM-2.

**7 Setup:** The setup date has no affect on actuator operation.

**8 Calbrtd:** The calibration date has no affect on actuator operation.

**9 Review:** Link to the Review menu.

**10 Poll addr:** Used to find the actuator. Most configurations should use "0".

### MENU 3C -- Configuration

The Configuration menu serves as the gateway to all of the drive operating parameters that can be used to configure the actuator based on the desired operation.

- 1 General Setup:** Link to General Setup menu.
- 2 PositionSensrSetup:** Link to PositionSensrSetup menu.
- 3 Demand Setup:** Link to Demand Setup menu.
- 4 Feedback Setup:** Link to Feedback Setup menu.
- 5 Torque Setup:** Link to Torque Setup menu.
- 6 Restore to Factory:** Restores field configurable parameters back to the settings in effect when the DCM-2 was shipped from the factory.
- 7 Use Default Setup:** Changes the DCM-2 position sensing voltage ranges to the proper ranges for the actuator model.

# APPENDIX HART<sup>®</sup> COMMUNICATION

## MENU 4B -- General Setup

This menu sets drive operating parameters. The nine parameter entries are as follows:

- 1 Drive Dir:** The direction the output shaft rotates (looking into the output shaft) in response to an increasing Demand signal.
- 2 MaxTravel:** The maximum available travel distance of the output shaft in degrees. This number corresponds to the actuator design—if the correct Serial Number is entered, this parameter should not be changed.
- 3 Travel:** The number of degrees of output shaft travel for 100% span.
- 4 StepSize:** The smallest Demand change that will cause an output shaft movement.
- 5 Stall Time:** The amount of time the motor will run before Stall Protection is initiated.
- 6 StallProt:** This entry is set as either "Enabled" or "Disabled". Stall protection removes motor power if "Stall Time" has expired.
- 7 LimitSwitch:** This entry is set as either "Accept" or "Alert" and defines whether or not contacting an overtravel limit switch (outside of the normal 0% to 100% travel range) will cause an alarm condition.
- 8 PositionUnit:** The numeric unit of measure for the output shaft position in angular degrees.
- 9 Temperature Unit:** The unit of measure for temperature sensing. May be "degF" (fahrenheit) or "degC" (celsius).

## MENU 4C -- PositionSensrSetup

This menu contains parameters that determine how the DCM-2 interprets the output shaft position signal from the Film Potentiometer.

- 1 Set Pos 0%:** Sets the 0% position to match the present output shaft position. This does not change the 100% position.
- 2 Set Pos 100% Span:** Sets the 100% position to match the present output shaft position. Also instructs the DCM-2 to change "Travel" span based on the 0% position. This does not change the 0% position.
- 3 PresCPS V:** Displays the Film Pot. signal voltage at the present output shaft position.
- 4 CPS Zero%:** Displays the Film Pot. voltage at the 0% output shaft position. May be edited to define the voltage at the lowest operating point of travel.

**5 CPS Span:** Displays the voltage signal span from the Film Pot. for the maximum rotation of the output shaft. This is the upper range voltage minus the lower range voltage. Not editable.

**6 CPS RngLwr:** Displays the Film Pot. voltage signal at the lowest possible point of travel. Not editable.

**7 CPS RngUpr:** Displays the Film Pot. voltage signal at the highest possible point of travel. Not editable.

**8 Pos S/N:** Displays the Serial number of the Film Pot. Has no effect on actuator function.

**9 Snsr Dir:** The direction of output shaft rotation that causes the Film Pot. signal to increase. This direction is typically CW and is not editable.

## MENU 4D -- Demand Setup

The parameters on this menu determine the range and characterization of the Demand signal. It also includes parameters that determine behavior when the Demand signal is absent.

**1 DemRngLwr:** Sets and displays the signal value in mA that represents 0% Demand (default is 4.00 mA, minimum is 0.5 mA). This value should be set above "DemLimLwr".

**2 DemRngUpr:** Sets and displays the signal value in mA that represents 100% Demand (default is 20.00 mA, maximum is 21.00 mA). This value should be set below "DemLimUpr".

**3 Dem Curve:** Determines the relationship between the Demand signal and the position of the output shaft. Typically set to Linear, but may also be set to Square, Square Root or customized Special Curve.

**4 Dem Curve Spcl:** Link to the "Dem Curve Spcl" menu.

**5 LOS Mode:** Action on loss of Demand signal.

**6 LOS Pos:** If the "LOS Mode" has been set to "Go-to-Pos", this defines where the output shaft will move (in percent of travel) during loss of Demand signal conditions.

**7 DemLimLwr:** Sets the threshold (in mA) below which the Demand signal is considered lost. This value should be set below "DemRngLwr".

**8 DemLimUpr:** Sets the threshold (in mA) above which the Demand signal is considered invalid. The Demand alarm will activate until the signal is brought below this level. This value should be set above "DemRngUpr".

**MENU 5A -- Dem Curve Spcl**

This menu allows setting the Demand signal characterization curve.

**MENU 4E -- Feedback Setup**

This menu is where all the Feedback signal related drive parameters are set.

- 1 FBRngLwr:** The value of the Feedback signal (in mA) that corresponds to a 0% output shaft position. This value can range between 3.00 mA and 16.00 mA (default = 4.00 mA).
- 2 FBRngUpr:** The value of the Feedback signal (in mA) that corresponds to a 100% output shaft position. This value can range between 7.00 mA and 21.00 mA (default = 20.00 mA).
- 3 Feedback:** Enables or Disables the Feedback signal.
- 4 FB Curve:** Allows a choice between a Feedback signal that linearly represents true shaft position or a characterized Feedback signal that inverts the effect of a characterized Demand signal.

**MENU 4F -- Torque Setup**

Not applicable to Group 75 actuators.

**MENU 3D -- Statistics**

This menu is where all the actuator's stored operating statistics are available.

- 1 Starts:** The total number of motor starts.
- 2 Reversals:** The total number of times the motor has started in the direction opposite to the previous start.
- 3 Stalls:** The total number of times the stall time has been exceeded.
- 4 OverTorques:** N/A
- 5 Pk Torque:** N/A.
- 6 TotRunTm:** Total amount of time the motor has been powered (in seconds).
- 7 High Temp:** Highest temperature recorded in the DCM-2 compartment (in degrees fahrenheit).
- 8 Low Temp:** Lowest temperature recorded in the DCM-2 compartment (in degrees fahrenheit).

**MENU 3E -- Manual Operation**

This menu is used to allow manual operation using HART® communications. There are three manual operation procedures available:

- 1 Op mode:** This procedure allows the user to select the operating mode of the DCM-2. There are four possible choices: "Follow", "Hold", "Stay" and "Stop". The "Follow" mode is the normal state of operation and allows the DCM-2 to control operation in response to the analog input Demand signal. The "Hold" mode forces the DCM-2 to position according to the HART Demand value (see below). The "Stay" mode forces the actuator to maintain its present position. Note that in "Stay" mode, the Handwheel cannot be freely turned. The "Stop" mode removes power from the motor. Note that in "Stop" mode the Handwheel can be freely turned. Note that the Handswitch overrides all operating modes.
- 2 Demand:** This procedure sets the effective Demand signal. If "Op mode" is set to "Hold", entering a valid value (-5% to 105%) will control the motor. If "Op mode" is set to "Follow", the value displays the Demand analog signal (unless an alarm condition exists).
- 3 Reset Stall:** This procedure resets normal actuator operation after a stall condition has caused the motor to shut down. Note that stall conditions can also be reset by simply reversing the input Demand signal or cycling the drive AC power.

**MENU 3F -- Diagnostics**

This menu provides access to all DCM-2 stored diagnostic information concerning actuator operation.

**MENU 4H -- Status**

This menu provides links to menus that monitor the operational status of the actuator. It also includes the display of one parameter.

- 5 Line Freq:** The power line frequency as measured by the DCM-2.

**MENU 5B -- LED Status**

The LED Status parameter allows remote checking of which LED's on the DCM-2 are illuminated.



# APPENDIX HART<sup>®</sup> COMMUNICATION

## MENU 5C -- Operating Status

The Operating Status parameter is a summary of whether process-related conditions are inside or outside of anticipated limits. These conditions control the Status Indication LEDs.

**1 Demand:** Caused by the Demand signal falling below or above acceptable levels.

**2 Position:** Caused by the Film Pot. signal being outside the range anticipated by the DCM-2.

**3 Temperature:** The ambient temperature of the DCM-2 is outside of the rating.

**4 Torque:** N/A.

**5 Overtorque Stop:** N/A.

**6 Stalled:** A Stall alarm is active.

**7 Feedback Open:** The Feedback signal is enabled, but cannot follow the proper current.

**8 Switch Block:** The DCM-2 cannot power the motor due to an electro-mechanical switch. Check the Handswitch and over-travel limit switches.

## MENU 5D -- Switch Status

Group 75 actuators display the Override & Handswitch parameters as ON or OFF. The "LV Lim CCW" & "LV Lim CW" parameters are not applicable.

## MENU 5E -- Local Cntrl Status

This parameter allows remote monitoring of which buttons on the local configuration interface are being pressed.

## MENU 5F -- CW Inhibitors

Allows viewing of the DCM-2 condition that is preventing the actuator motor from running in the CW direction.

## MENU 5G -- CCW Inhibitors

Allows viewing of the DCM-2 condition that is preventing the actuator motor from running in the CCW direction.

## MENU 4I -- Tests

The Tests menu provides access to some routines that help determine if the actuator is running properly.

**1 FB Out Test:** Allows manual verification of the Feedback output signal to check operation and accuracy.

**2 Board Self-Test:** Instructs the DCM-2 to check various power and sensing circuits. This test will cause the actuator to reposition, so it should be run offline and only when a DCM-2 problem is suspected.

**3 Identify Device:** Causes the ACKNOWLEDGE LED on the DCM-2 to flash for two seconds. Ensures the HART system is addressing the correct actuator.

**4 Board Reset:** Causes the DCM-2 to initiate a reset cycle similar to a power-up reset. This manual reset will cause the actuator to reposition. This procedure is not typically necessary.

## MENU 4J -- CW Torque

Not applicable to Group 75 actuators.

## MENU 4K -- CCW Torque

Not applicable to Group 75 actuators.

## MENU 4L -- Alarm Setup

The Alarm Setup menu parameters allow modification of the behavior of the alarm output solid state relay.

**1 AlarmPol:** Whether the solid state relay opens on alarm or closes on alarm.

**2 Alarm Mask:** Link to the Alarm Mask menu which allows specific alarm conditions to be ignored.

## MENU 5H -- Alarm Mask

Allows selection of alarm conditions that will not cause an alarm.

---

### **MENU 4M -- RealTimeClock**

This menu allows the date and time to be set.

- 1 RTC Day:** Day of the month (numeric value).
- 2 RTC Month:** Month (numeric value).
- 3 RTC Year:** Year (4 digits).
- 4 Hour (24):** Hour of the day (24 hour format).
- 5 Minute:** Minute of the hour (0 through 59).

### **MENU 3G -- Calibration Trim**

The Calibration Trim menu sets and displays actuator calibration values. Note that changing the calibration trim can cause signal measurement difficulties if performed improperly.

**1 PresCPS V:** Displays and/or trims the present voltage of the position signal. This value may also be measured at DCM-2 test points TP1(-) and TP4(+). This trim is set and tested at the factory. Changing this value can cause voltage measurement errors.

**2 Loop(Dem):** Displays the Demand signal as measured at the field wiring terminals. When the Demand control loop signal is being overridden by a special mode of operation, the effective Demand will not correspond to the mA value. This value can be edited to trim the Demand to ensure accurate measurement of the analog signal. Demand can only be trimmed at 4.0 mA and 20.0 mA.

**3 Feedback:** Displays the mA signal representing the output shaft position as measured at the field wiring terminals. This value can be edited.

**4 Trq/Thrust:** N/A.

# APPENDIX HART<sup>®</sup> MESSAGES

## COMMON HART<sup>®</sup> MESSAGES

HART<sup>®</sup> protocol maintains both standard and device specific informational messages that are displayed on the Communicator when various conditions occur.

Below is a table of typical Beck drive messages and message sequences. It does not include all possible messages, only the most common.

### Output Shaft Position Measurement Messages

Message	Description
"Process applied to the primary variable is outside the operating limits of the field device."	This is a standard HART-defined message that appears whenever the HART primary variable (Position signal) is outside the design or calibrated range. This message should be accompanied by a Beck-specific message with more detail.
"The Position Signal is less than -5% or greater than 105%."	This Beck-specific message indicates the DCM-2 is reading a Position signal not within the calibration range limits.
"Position signal in LOS."	This is a Beck-specific message. The DCM-2 is indicating that the Position signal is a problem and is intended to identify a Film Potentiometer or wiring failure. This is triggered when the Position signal is outside the minimum and maximum voltage limits.
"Position out of accurate measurement range."	This is a Beck-specific message. The DCM-2 indicates the Position signal is outside of the design range.
"Position sensing error."	This is a Beck-specific message. The DCM-2 circuitry for measuring the Position signal does not appear to be functioning properly.
"Analog output 1 and its digital representation are outside the operating range limits, and not responding to input."	This is a standard HART-defined message that appears whenever the position signal to the DCM-2 is outside the design or calibrated range. This message should be accompanied by a Beck-specific message with more detail.

### Handswitch and Over-travel Limit Switch Message

Message	Description
"Motor power is blocked, check switches."	This message will appear if the DCM-2 detects a condition that prevents current flow to the motor.

### Stall Protection Message

Message	Description
"Stall condition has been detected (see 'Stall Time' in the 'General Setup' menu)."	This is a Beck-specific message indicating that the actuator is in a stalled condition. This occurs if the actuator cannot reach the Demand position in the time allotted by the stall time setting (configurable from 30–300 seconds).

## Demand and Temperature Measurement Messages

Message	Description
"Process applied to the non-primary variable is outside the operating limits of the field device."	This is a standard HART-defined message that appears whenever the Demand signal or Temperature are outside their design or calibrated ranges. This message should be accompanied by a Beck-specific message with more detail.
"The Demand Signal is outside of the intended limits (see Demand Setup menu)."	This Beck-specific message indicates the Demand signal is invalid.
"Demand out of accurate measurement range."	This is a Beck-specific message that the Demand signal is not only out of the calibrated range, but also out of the design range of the actuator. The lower and upper limits are 0.1 V dc and 5.5 V dc, respectively. Note that current input DCM-2 boards utilize a 250 Ohm input resistor to convert the current signal to voltage.
Demand Signal is out of limit.	This Beck-specific message indicates the Demand signal is too high to measure accurately. The upper limit is 5.5 V dc. Note that current input DCM-2 boards utilize a 250 Ohm input resistor to convert the current signal to voltage.
Demand sensing error.	This is a Beck-specific message. The Demand sensing circuitry does not appear to be functioning properly.
The temperature is outside of -40°F to 185°F.	This is a Beck-specific message indicating that the temperature at the DCM-2 is outside of the acceptable range.
Temperature out of accurate measurement range.	This is a Beck-specific message. The DCM-2 ambient temperature reading is extreme and cannot be accurately measured.
Temperature A/D Fail.	This is a Beck-specific message. The DCM-2 circuitry for measuring the ambient temperature does not appear to be functioning properly.
The Feedback Signal is enabled but the loop is open.	This is a Beck-specific message indicating that the Feedback sourcing circuit is unable to create the proper signal current. This message could result from the signal not being wired to an external load, or a wiring failure has occurred at some point between the actuator and the monitoring device.

# APPENDIX HART<sup>®</sup> MESSAGES

## Questionable Configuration Messages

Message	Description
Analog output 1 and its digital representation are in fixed mode, and not responsive to input changes.	This is a standard HART-defined message that appears whenever the Feedback signal has been manually assigned a value. This message should be accompanied by a Beck-specific message with more detail.
Feedback is in fixed mode.	This is a Beck-specific message indicating that the Feedback signal has been manually set to a fixed value and is not following the Position value.
Local control button pressed while locked-out.	This is a Beck-specific message indicating an incorrect combination of pushbuttons is being pressed on the local configuration interface, or the local control interface is disabled and a pushbutton is being pressed.
Loop Current Detected while under HART/FF Control.	This is a Beck specific alarm message that alerts the user that analog current is present on the Demand terminals, but the DCM-2 is in an Op Mode expecting digital control. Make certain the Op Mode parameter is set properly.
Loop Current Detected while set for LOS PAT.	This is a Beck specific alarm message that alerts the user that analog current is present on the Demand terminals, but the DCM-2 is set to a LOS mode intended to be used without an analog signal.

## DCM-2 Failure Messages

Message	Description
Real Time Clock hardware failure.	This is a Beck-specific message. The data in the Real Time Clock appears invalid.
FRAM Memory has failed.	This is a Beck-specific message. The continuous built-in self-test cannot verify the memory for statistics information is operating properly.
Memory failure.	This is a Beck-specific message. The continuous built-in self-test cannot verify the microcomputer is operating properly.



---

### Miscellaneous HART-Defined Messages

Message	Description
Field device has more status available.	This is a standard HART-defined message that appears whenever the DCM-2 signals the HART master that an alarm or other undesirable status exists. This is the HART protocol mechanism for displaying the other messages in this section. If this message is displayed without an additional message, the status cleared before the HART master read the additional status.
A reset or self-test of the field device has occurred, or power has been removed and reapplied.	This message is presented by the HART master if the DCM-2 has gone through a power-up reset sequence since the last communication with the master. This message is only displayed once after a reset.
A modification has been made to the configuration of the field device.	This message indicates that the DCM-2 has undergone a configuration change since the last time the HART master has reset the change flag. Many HART masters disregard the flag and do not report this message.
Field device has malfunctioned due to a hardware error or failure.	This message indicates that the continuous built-in self-test cannot verify the microcomputer is operating properly.

# APPENDIX SERIAL COMMUNICATION

## COMMUNICATIONS

Local configuration of the Beck actuator can be accomplished using Serial commands through the DCM-2 Serial port.



### CAUTION

**Changes made to the actuator through Serial communications may not necessarily be reflected in asset management systems. Be sure to verify any changes made serially and make manual corrections to the asset management system if necessary.**

The Beck Digital Control Module (DCM-2) is equipped with a Serial interface which allows for direct communication with a computer. Using a communication cable (see illustration on page 63), connect the DCM-2 to the computer using the DCM-2's RS-232 (J20) connector (see illustration on this page) and the computer's COM port. Ensure that the COM port on the computer is active, and that the cable is plugged into the proper COM port if more than one is present (e.g., COM1, COM2, etc.). Note that a plug end adapter may be necessary for connection to the computer's COM port.

Once connected, communication can be established between the DCM-2 and the computer using a terminal emulation program, such as HyperTerminal®. This method of communication will allow for configuration, calibration and verification of actuator DCM-2 settings without the use of custom software applications.



RS-232  
CONNECTOR

## HyperTerminal® SOFTWARE

HyperTerminal is the standard ASCII terminal emulation software provided with Microsoft® Windows®. If using HyperTerminal®, the following instructions will assist in setup and assume use of the Beck Serial cable (see following page). Note that some variation to these instructions may be necessary depending on the version of HyperTerminal® being used.

The RJ-11 connector (on the Beck Serial cable) should be attached to the RS-232 port on the DCM-2 (see graphic on bottom of page for location). The other end of the Beck Serial cable (the DB-9 connector) should then be plugged into a windows-based computer. Some computers may require a Serial adaptor such as a USB/Serial converter to communicate.

Access HyperTerminal® by clicking first on "Start", then "Programs", then "Accessories", then "Communications", then "HyperTerminal". Double-click on the "Hypertrm.exe" icon to start the program. Once HyperTerminal® is running, it is necessary to set up a file with the proper settings to communicate with the DCM-2. Proceed as follows:

1. If prompted to install a modem, answer "no". Proceed to enter a name (e.g., "DCM-2") and select an icon (any will suffice) in the "Connection Description" box. Click the "OK" button.
2. The "Connect to" box should open next. At the bottom of the box, set the "Connect using" selection to the computer COM port that has been connected to the DCM-2. Click the "OK" button.
3. The COM port properties box should open next; this is where the communication settings are established. The correct settings are:
  - a. Bits per second = "1200"
  - b. Data bits = "8"
  - c. Parity = "none"
  - d. Stop bits = "1"
  - e. Flow control = "none"
4. With the appropriate settings entered from Step 3, above, click "OK". Communications should now be enabled.
5. Press the "Enter" key twice. "OK" should be displayed indicating that HyperTerminal® is communicating with the DCM-2.

Hyperterminal® is a product of Hilgraeve, Inc.

# APPENDIX SERIAL COMMANDS

## COMMANDS AND ARGUMENTS

Commands can be used for a variety of functions including changing the operating configuration of the actuator, verifying operation settings, calibration and accessing diagnostic information. There are essentially four different types of commands:

1. Dual-purpose commands. These commands can be used to either modify actuator configuration settings or display the settings already set in the actuator. In order to set or make a change to the settings, the command requires an argument (*n*). If the command is used for display purposes only, the argument is omitted. Examples of these commands include "temperature" and "demlos".
2. Display only commands. These commands are used to display diagnostic or operating information such as present signal values. No arguments are required. Examples include the "stat" command and the "signals" command.
3. Set only commands. These commands serve only to make a parameter change. Typically, they apply to the actuator calibration. This type of command requires an argument, but unlike dual-purpose commands, they return an error message when entered without an argument. Examples include the "charset" and "trimfdbk4mA" command.
4. Execute action commands. These commands serve to reset, enable or disable features. Entering these commands produces an immediate action. Examples include the "configformodel 1" and "restoremodes 1" command.

The available commands are listed on the next several pages and each is described in detail. The command description explains the use or uses of the command, while the argument column describes any applicable arguments. Arguments are denoted as *n*. Note that the commands described as "sets and/or displays" signify dual-purpose commands that can be used with or without an argument for setting or verifying configuration settings.

**Beck Serial Cable Pinout Table**

RJ-11 6-PIN PLUG PIN NO.	DB-9 9-PIN PLUG PIN NO.
1	8
2	2
3	9
4	5
5	3
6	7

**Beck Serial Cable Illustration  
(Part Number 20-0511-13)**

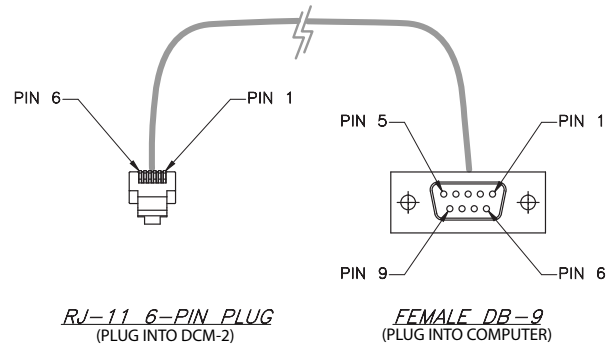

# APPENDIX SERIAL COMMANDS

## SERIAL COMMANDS

The following is a categorized list of Serial commands available through the RS-232 interface. These commands are described in detail on the pages that follow.

### Output Shaft Position Sensing Commands

cpsvat0pct	travel
------------	--------

### General Configuration Commands

alarmout	restoremodes
alarmoutmask	sernum
configformodel	stallprot
drvdir	stalltime
limitalarm	stepsize
opmode	

### HART® Configuration Commands

harttype	polladdr
----------	----------

### Diagnostic and Information Commands

demsources	signals
help	stat
ledtest	temperature
reset	unstall

### Demand Signal Commands

dem0pctma	demlostgtp
dem100pctma	trimdem4ma
demlos	trimdem20ma

### Demand Characterizer Commands

charclear	charset
charlist	demfunc

### Feedback Signal Commands

fdbk0pctma	trimfdbk4ma
fdbk100pctma	trimfdbk20ma
fdbkfunc	iomode

## Output Shaft Position Sensing Commands

Command	Description	Argument <i>n</i> and Information
cpsvat0pct <i>n</i>	Sets/displays the DCM-2 voltage setting used to determine 0% signal from the film potentiometer. Voltage is dependent upon the actuator model. Typically, this setting does not need to be changed.	<i>n</i> = desired voltage as a decimal (carried out to 3 decimal places). The standard signal range for an actuator configured for 100 degrees of output shaft rotation is approx. 1.000–5.000 V.
travel <i>n</i>	Sets/displays the number of degrees that represents 100% travel. This command does not shift the 0% position; when increasing travel from a reduced travel setting, the 0% position may need to be changed first to keep travel within acceptable end points. The end points are defined by the film potentiometer voltage range.	<i>n</i> = desired length of travel in degrees. This value cannot exceed the maximum output shaft rotation of the actuator.

## General Configuration Commands

Command	Description	Argument <i>n</i> and Information
alarmout <i>n</i>	Sets/displays the polarity of the alarm output solid state relay.	<i>n</i> = "0": open on Alarm <i>n</i> = "1": closed on Alarm Upon loss of power, the relay is open regardless of the setting.
alarmoutmask <i>n</i>	Sets/displays (in hexadecimal format) which conditions will cause an alarm: 0x00000001 - Demand Loss of Signal 0x00000004 - Stall Condition 0x00000010 - Stop/Limit 0x00000020 - Feedback Loss of Signal 0x00000040 - Temperature too High/Low 0x00000080 - Position Outside of Limits 0x00000100 - Real Time Clock Failure 0x00000400 - Position Analog/Digital Circuit Failure 0x00000800 - Demand Measurement Failure 0x00002000 - Position Loss of Signal 0x00004000 - Temperature Measurement Failure 0x00008000 - Memory Failure 0x00010000 - Invalid Button Pressed 0x00020000 - Demand too High	<i>n</i> = "0x0": no listed condition causes a status alarm <i>n</i> = "0xffffffff": all listed conditions cause a status alarm <i>n</i> = hexadecimal value for specific condition(s) which will cause an alarm. Multiple conditions may be selected by performing a hexadecimal addition of the condition values; e.g., Stall Condition and Stop/Limit alarms -- hex 0x04 + 0x10 = 0x14.
configformodel <i>n</i>	Sets certain DCM-2 default values based on the actuator Serial number. These values are direction rotation for an increasing Film Pot. signal, expected range of Film Pot. signal, and the maximum travel.	<i>n</i> = "1": executes command
drvdir <i>n</i>	Sets/displays the actuator output shaft rotation direction resulting from an increasing Demand signal.	<i>n</i> = "0": CW rotation <i>n</i> = "1": CCW rotation
limitalarm <i>n</i>	Sets/displays alarm if the actuator travels outside of the 0% to 100% travel limits.	<i>n</i> = "0": mute (no alarm) <i>n</i> = "1": always
opmode <i>n</i>	Sets/displays the mode that controls the Demand signal source. This mode selects analog or digital control.	<i>n</i> = "0": analog Demand <i>n</i> = "1": digital Demand <i>n</i> = "2": run CW <i>n</i> = "3": run CCW <i>n</i> = "4": stay <i>n</i> = "5": stop
restoremodes <i>n</i>	Returns the DCM-2 settings to the original factory configuration.	<i>n</i> = "1": executes command
sernum <i>n</i>	Sets the actuator Serial number.	<i>n</i> = Serial number
stallprot <i>n</i>	Sets/displays stall protection state.	<i>n</i> = "0": disabled <i>n</i> = "1": enabled
stalltime <i>n</i>	Sets/displays time the actuator runs in one direction before stall alarm is activated.	<i>n</i> = seconds: acceptable range is 30–300 seconds.
stepsize <i>n</i> %	Sets/displays the size of one incremental movement of the output shaft.	<i>n</i> = % of travel desired: acceptable range is 0.10%–2.5%. Include the "%" symbol after the number, otherwise the unit of measure will be degrees.



# APPENDIX SERIAL COMMANDS

## HART® Configuration Commands

Command	Description	Argument <i>n</i> and Information
harttype <i>n</i>	Sets/displays the DCM-2 HART DD (Device Description). "239" is the proper DD; other DDs are for temporary use if the new DD is not available.	<i>n</i> = "1": ESR-D <i>n</i> = "10": Beck DCM <i>n</i> = "239": Beck MK2
polladdr <i>n</i>	Sets/displays the polling address used by the HART master to find individual devices if the HART bus has more than one device.	<i>n</i> = the polling address (a number between "0" and "15"). Unless multiple HART devices are connected in parallel on a single bus, the polling address should be set to "0".

## Diagnostic and Information Commands

Command	Description	Argument <i>n</i> and Information
demsorce	Provides a readout of information regarding the Demand on the actuator including the source of the Demand signal (Handswitch, demlos or Analog I/P), mode (follow, hold, CW, CCW, Stay or Stop), currently applied Demand signal as a %, the Demand function (linear, square root, square, or special), and the Demand out as a % (dem out shows the signal adjusted when using a non-linear Demand function (demfunc command)).	No Argument
help <i>n</i>	Displays help text for a specific command or lists all available Serial commands.	<i>n</i> = command name <i>n</i> = "all"
ledtest <i>n</i>	Tests the functionality of the DCM-2 LEDs individually or as a group. If "all" is selected, the command will consecutively cycle through each LED twice. If an individual LED is selected, it will flash 12 times.	<i>n</i> = "1": DEMAND <i>n</i> = "2": POSITION <i>n</i> = "4": STALL <i>n</i> = "5": TEMP °F <i>n</i> = "6": FB OPEN <i>n</i> = "7": STOP/LIMIT <i>n</i> = "8": ACKNOWLEDGE <i>n</i> = "100": FWD <i>n</i> = "101": REV <i>n</i> = "102": STAT <i>n</i> = "All"
reset <i>n</i>	Performs the same reset sequence as when power is removed and reapplied.	<i>n</i> = "1": must equal "1" for command to execute.
signals	Displays the present DCM-2 readings of four signals: Position signal from Film Pot. Demand Feedback Torque (N/A)	No argument = signal readings are displayed. <i>n</i> = "all": an extended set of data is displayed.

---

**Diagnostic and Information Commands (con't)**

Command	Description	Argument <i>n</i> and Information
stat	Displays information on the status of the actuator, including: Time / Date Demand Position Error ( Demand minus Position) Step size Dead band Motor Status Motor Run Time Line Frequency Motor Starts Motor Reversals/Stalls CW and CCW Inhibitor Status Alarms	No argument
temperature <i>n</i>	Displays three values describing the ambient temperature in the actuator. Low extreme, present, high extreme. Can also change the temperature units.	No argument = temperatures are displayed. <i>n</i> = "F": changes units to Fahrenheit <i>n</i> = "C": changes units to Celsius
un stall	Resets the Stall Protection alarm to restore power to the motor. If the motor is still physically stalled, the Stall Protection alarm will recur.	No argument.

# APPENDIX SERIAL COMMANDS

## Demand Signal Commands

Command	Description	Argument <i>n</i> and Information
dem0pctma <i>n</i>	Sets/displays the Demand signal value that corresponds to 0% actuator position.	<i>n</i> = Demand signal as a decimal in mA. Minimum value is 0.50; maximum value is 100% Demand less 4.00 mA (e.g., if 100% Demand is 20.00 mA, the 0% value must be set for 16.00 mA or less).
dem100pctma <i>n</i>	Sets/displays the Demand signal value that corresponds to 100% actuator position.	<i>n</i> = Demand signal as a decimal in mA. Minimum value is 0% Demand plus 4.00 mA (e.g., if 0% Demand is 4.00 mA, the 100% value must be set for 8.00 mA or greater). Maximum value is 21.00 mA.
demlos <i>n</i>	Sets/displays the Demand signal threshold, below which the DCM-2 recognizes the signal has been lost. The threshold is entered as a value in mA. This command also sets/displays the action initiated by the drive during LOS (Loss Of Signal). LOS action options are "sip" (stay in place) or "gtp" (go to position). Demlos always reports both settings, but only sets one argument at a time. Demlos must be used twice to set both the threshold and action.	<i>n</i> = Demand signal in mA below which LOS occurs (e.g., the typical value for a 4–20 mA system is 3.20). -OR- <i>n</i> = "sip", "gtp" or "pat". The "pat" argument acts the same as "sip", but also suppresses the alarm--this is used in some pulsed applications.
demlogtp <i>n</i>	Sets/displays the position to which the actuator will run upon loss of the Demand signal (LOS). This command has no effect if the actuator is set to "sip" (stay in place).	<i>n</i> = desired position of actuator expressed as a percentage of actuator travel in decimal form (e.g., 50% = 50.00).
trimdem4ma 4	Trims the Demand analog-to-digital sensing circuit to be accurate at 4 mA. This command should only be used when the Demand signal at the actuator is exactly 4.0 mA. Trim is factory set and should not normally require recalibration.	"4" is the only acceptable value; this trim can only be performed at 4 mA.
trimdem20ma 20	Trims the Demand analog-to-digital sensing circuit to be accurate at 20 mA. This command should only be used when the Demand signal at the actuator is exactly 20.0 mA. Trim is factory set and should not normally require recalibration.	"20" is the only acceptable value; this trim can only be performed at 20 mA.

## Demand Characterizer Commands

Command	Description	Argument <i>n</i> and Information
charclear <i>n</i>	Clears a preconfigured Demand characterizer curve node by setting it to "unused". Any node numerically higher will be set to "unused" also.	<i>n</i> = node number: between 1 and 21.
charlist <i>n</i>	Displays the X-values and Y-values of Demand characterizer curve node(s).	<i>n</i> = node number: between 1 and 21. <i>n</i> = "all": displays all nodes
charset <i>n1, n2, n3</i>	Sets the X-values and Y-values of a specific node of the characterizer curve. The three arguments must be separated by commas.	<i>n1, n2, n3</i> = ( <i>n1</i> is node number to modify, <i>n2</i> is X-value as a percentage, <i>n3</i> is Y-value as a percentage)
demfunc <i>n</i>	Sets/displays the Demand signal characterization function.	<i>n</i> = "0": linear <i>n</i> = "1": square root <i>n</i> = "4": special curve <i>n</i> = "5": square

## Feedback Signal Commands

Command	Description	Argument <i>n</i> and Information
fdbk0pctma <i>n</i>	Sets/displays the mA value of the Feedback signal that represents the 0% output shaft position.	<i>n</i> = desired Feedback signal in mA at 0% output shaft position. Minimum value is 3.00 mA and the maximum must be at least 4.00 mA less than the Feedback signal value for the 100% output shaft position.
fdbk100pctma <i>n</i>	Sets/displays the mA value of the Feedback signal that represents the 100% output shaft position.	<i>n</i> = desired Feedback signal in mA at 100% output shaft position. Minimum value must be at least 4.00 mA greater than the Feedback signal value for the 0% output shaft position. Maximum value is 21.00 mA.
fdbkfunc <i>n</i>	Sets/displays the curve used to calculate the Feedback signal.	<i>n</i> = "0": linear <i>n</i> = "1": inverse Demand (curve enabled)
trimfdbk4mA <i>n</i>	Trims the Feedback signal at 4 mA. Calibrated at the factory, should not normally require calibration.	<i>n</i> = present Feedback signal from the DCM-2 in mA.
trimfdbk20mA <i>n</i>	Trims the Feedback signal at 20 mA. Calibrated at the factory, should not normally require calibration.	<i>n</i> = present Feedback signal from the DCM-2 in mA.
iomode <i>n</i>	Sets/displays the function of a DCM-2 connector pin. May be enabled for Feedback or potentiometer.	<i>n</i> = "0": none <i>n</i> = "1": Feedback enabled <i>n</i> = "2": potentiometer power enabled.

# INDEX

Appendices .....	51–69	Restore Factory Settings .....	25
HART® Communication .....	51–57	Safety Precautions .....	8
HART® Messages .....	58–61	Self-Locking Mechanism (SLM).....	36–37
Serial Communication .....	62	Serial Commands .....	63–69
Serial Commands .....	63–69	Serial Communication .....	62
Applications Reviews.....	71	Services.....	71
Auxiliary Limit Switches .....	23	Site Surveys .....	71
Setting Switches .....	23	Specification Writing .....	71
Configuration/Calibration .....	22–33	Stall Protection .....	33
Demand Calibration.....	27	Start-up.....	16
Demand Characterization Curves .....	29–30	Step Size .....	25
Digital Control Module (DCM-2) .....	18–21	Storage Information .....	8
Interfaces.....	19	Table of Contents.....	3
Overview LEDs.....	20	Temperature Sensing .....	32
Status Indication LEDs .....	21	Travel (Degrees Rotation) .....	26
Pushbutton Controls .....	21	Troubleshooting.....	46–50
Direction of Output Shaft Rotation.....	24	Warranty Statement.....	71
Electronics .....	18–21		
Film Potentiometer .....	42–43		
General Specifications.....	4–5		
Handswitch .....	9, 44		
Handwheel.....	9		
HART® Communication.....	51–57		
HART® Device Description Menu.....	51		
HART® Messages .....	58–61		
How to Obtain Service.....	71		
Installation .....	10–15		
Electrical .....	14		
Mechanical .....	10–13		
Valves .....	10		
Linkage-connected .....	10–13		
Link-Assist™ .....	12		
Direct-Mount.....	10		
Wiring .....	15		
Introduction.....	2		
Limit Switches (Over-travel) .....	22		
Setting Switches .....	22		
Linkage Kits .....	12		
Loss of Demand Signal (LOS).....	28		
Maintenance .....	36–45		
Motor Assembly .....	34		
Motor Capacitor & Resistor Assembly ...	35, 45		
Over-travel Limit & Auxiliary Switches .....	38		
DCM-2 Board.....	39		
Terminal Board .....	40–41		
Film Potentiometer .....	42–43		
Handswitch .....	44		
Gaskets .....	44		
Outline Dimension Drawings .....	6–7		
Position Feedback Signal .....	31–32		
Power Quality .....	14		
Product Demonstrations .....	71		
Recommended Spare Parts .....	45		



# SERVICES

---

## PRODUCT DEMONSTRATIONS

Each of Beck's Sales Engineers has access to a complete set of actuator models so that he can demonstrate virtually any of their features at your location. In order to arrange to see a Beck actuator in your plant or office, contact Beck's Sales Department.

## SITE SURVEYS

Beck Sales Engineers are available to discuss your process control requirements. Often a visit to your location is the best way to gain a thorough understanding of your needs, in order to meet them most accurately and completely.

Mounting hardware, torque requirements, linkage, control signal information, and optional equipment can be analyzed most effectively at the work site. Beck's analysis at the job site can help ensure that specifications are accurate, especially in the case of complex applications.

## APPLICATION REVIEWS

By sharing your needs with a Beck Sales Engineer you can take advantage of the best application advice for the type of control you need.

This review will yield a better understanding of the versatility of Beck actuators for your installations, as well as complete details on options and accessories to make the process as effective as possible.

## SPECIFICATION WRITING

Beck provides specification writing assistance in order to help you specify and order the right actuators for your applications. Beck Sales Engineers will work with you to make it easier for you to obtain the proper equipment and give you confidence that no details are overlooked.

## HOW TO OBTAIN SERVICE

Factory repair of actuators or subassemblies is available for both normal and emergency service. To assure prompt processing, contact the factory to receive a Returned Material Authorization (RMA) number. If a repair estimation is desired, please send the name and phone number of your contact for service authorization. It is helpful to include a description of the work desired with the shipment or, in the event of a problem, the malfunction being experienced.

## THREE YEAR LIMITED WARRANTY STATEMENT\*

Harold Beck & Sons, Inc. (Beck) warrants that our equipment shall conform to Beck's standard specifications. Beck warrants said equipment to be free from defects in materials and workmanship. This warranty applies to normal recommended use and service for three years from the date on which the equipment is shipped. Improper installation, misuse, improper maintenance, and normal wear and tear are not covered.

The Buyer must notify Beck of any warranty issues within 37 months of original shipment date and return the goods in question, at Buyer's expense, to Beck for evaluation. If the product fails to conform to the warranty, Beck's sole obligation and the Buyer's exclusive remedy will be: 1) the repair or replacement, without charge, at Beck's factory, of any defective equipment covered by this warranty, or 2) at Beck's option, a full refund of the purchase price. In no event will Beck's liability exceed the contract price for the goods claimed to be defective.

THIS WARRANTY IS EXPRESSLY IN LIEU OF ANY OTHER EXPRESS OR IMPLIED WARRANTY, INCLUDING IMPLIED WARRANTIES OF MERCHANTABILITY AND FITNESS FOR A PARTICULAR PURPOSE, AND ALL OTHER OBLIGATIONS OR LIABILITIES OF BECK. In no case shall Beck be liable for any special, incidental or consequential damages based upon breach of warranty, breach of contract, negligence, strict tort, or any other legal theory. Such damages include, but are not limited to, loss of profits, loss of revenue, loss of use of the equipment or any associated equipment, cost of capital, cost of any substitute equipment, facilities or service, downtime, the claims of third parties including customers and injury to property.

Buyer acknowledges its responsibilities under OSHA, related laws and regulations, and other safety laws, regulations, standards, practices or recommendations that are principally directed to the use of equipment in its operating environment. Buyer acknowledges that the conditions under which the equipment will be used, its use or combination with, or proximity to, other equipment, and other circumstances of the operation of such equipment are matters beyond Beck's control. **Buyer hereby agrees to indemnify Beck against all claims, damages, costs or liabilities (including but not limited to, attorney's fees and other legal expenses), whether on account of negligence or otherwise, except those claims based solely upon the negligence of Beck and those claims asserted by Beck's employees which arise out of or result from the operation or use of the equipment by Beck's employees.**

---

\*Note: Internal water damage is not covered by warranty.

© Copyright 2013 by Harold Beck & Sons, Inc.

Beck Control Actuators are covered by the following patents: 3,667,578; 4,690,168; 6,563,412 B2; 6,639,375 B2 and 6,769,527 B1 with other patents pending.



**BECK**<sup>®</sup>

**HAROLD BECK & SONS, INC.**

Made in USA



11 TERRY DRIVE • NEWTOWN, PENNSYLVANIA 18940 • USA

PHONE: 215-968-4600 • FAX: 215-860-6383 • E-MAIL: [sales@haroldbeck.com](mailto:sales@haroldbeck.com)

[www.haroldbeck.com](http://www.haroldbeck.com)