



BACKUP POWER UNIT FOR ORDINARY LOCATIONS

**P/Ns 20-3111-12 (Single Bank of Ultra-Capacitors)
& 20-3111-14 (Dual Bank of Ultra-Capacitors)**



The Beck Backup Power Unit (BPU) provides short-duration, backup power for Beck actuators. It is designed to provide power for fail-to-position actuator response or to maintain normal actuator operation for a short period. The Backup Power Unit is different from most similar devices, as it utilizes ultra-capacitors to store energy instead of a battery. The capacitors eliminate concerns associated with battery devices since they provide much longer life and higher reliability.

The Backup Power Unit utilizes a cast aluminum, Type 4X enclosure. The unit may be mounted anywhere and does not require close proximity to the actuator.

The unit is also available with an additional bank of ultra-capacitors to provide backup power for a longer period of time.

SPECIFICATIONS

- Low power draw (0.2A)
- 1 Amp. maximum supply capability
- Up to ~2 ¼ minutes backup time (~4 ½ minutes backup time with additional ultra-capacitor bank (see below))
- Power discharge switch (Control Switch S1)
- Temperature rated -40° to 60° C. (-40° to 140° F.)
- Weatherproof enclosure: Type 4X, IP66 & IP68 (3 meters/48 hours)
- External status indication lights
- Self-contained—mounts anywhere in any orientation
- Maintenance-free—uses ultra capacitor technology, no battery replacement is required
- Auto charge and recharge (see below)
- Power status relay outputs
- Dual conduit entrances

Fully charged, the unit will provide backup power for a time dependent upon the power draw required by the actuator motor. Approximate times for the duration of output power follow. Note: These time estimates reflect a 20% safety factor over empirical data.

~ BACKUP TIME*

Watts**	20-3111-12 Single Bank (seconds)	20-3111-14 Dual Bank (seconds)
34	109	218
62	58	116
87	44	88
101	37	74

* At standard room temperature.

**1 Amp. maximum supply capability.

~ CHARGING TIME

Backup Unit State	20-3111-12 Single Bank (minutes)	20-3111-14 Dual Bank (minutes)
Fully Discharged	30	60
From point at which "AC OUTPUT READY" light first shuts off	17	34



WARNING

LETHAL VOLTAGE POTENTIAL! Proceed with extreme caution. Before making any adjustments or connections to the circuit board, ensure that the unit is completely de-energized (see page 4)—input power must be disconnected and output power must be inactive.

WARNING

Installation and service instructions are for use by qualified personnel only. To avoid injury, do not perform any servicing other than that contained in this instruction. Please read and understand this instruction before attempting to install or operate the Backup Power Unit. All installation and service should be carried out in accordance with applicable standards and codes.

INSTALLATION & SETUP



CAUTION

To prevent Electrostatic Discharge (ESD) damage, follow established ESD control procedures when touching the circuit board assembly.

Refer to the photo on page 5 for component identification.

1. Mount the Backup Power Unit in the desired location—close proximity to the actuator is not necessary.
2. Remove the 10 cover screws (M8 x 1.25 x 30mm), then carefully remove the cover to gain access to the circuit board assembly. **DO NOT FORCEFULLY REMOVE THE COVER**—this may cause damage to the mating surfaces. If needed, use jacking screws (recommend M8 x 1.25 x 40mm) in the appropriate holes (see the outline dimensions on the back cover for location) to evenly separate the cover from the housing.



CAUTION

Damage sustained during setup and service (including cover removal and replacement) resulting from improper handling is not covered under warranty. Beck cannot be liable for any such damage which includes, but is not limited to, damage to the BPU cover-to-body interface which will affect the integrity of the seal protecting internal components.

3. Set S1 (control switch) to the 'on/charge' position (upward towards switch S2) for normal operation.
4. Complete the input, output and other desired wiring connections as shown in the appropriate wiring diagram beginning on page 6. If desired, specific wiring diagrams are available upon request.
5. Verify that the unit has been set to the output frequency specified in the order. Locate S2 (voltage frequency switch - see page 5) on the circuit board. Use a flat-tipped screwdriver to turn the switch to the desired output frequency. Turning the switch CW until it stops sets the frequency to 60 Hz. Turning the switch CCW until it stops sets the frequency to 50 Hz.

6. Carefully replace the cover. **DO NOT FORCEFULLY REPLACE THE COVER**—this may cause damage to the mating surfaces. Torque the cover screws to 18 lb-ft (24 N•m).
7. Energize input power.



CAUTION

Reinstall cover immediately after installation or service to prevent moisture or other foreign matter from entering the unit.

After connections have been made and power applied, the status of the Backup Power Unit may be determined by viewing the Indicator Lights located on the front of the unit:

"AC INPUT AVAILABLE" lights when outside power is applied to the unit. When outside power is interrupted or unavailable, this light is off.

"PARTIAL CHARGE" lights when the unit has stored power. This serves as a warning that there is potentially hazardous voltage across the circuit board.

"AC OUTPUT READY" lights when the unit is ready to provide backup power. When the unit is operational and discharging (outside power is no longer available), this light will remain on until backup power is no longer sufficient to operate the actuator. Remote indication of "AC OUTPUT READY" is available at TB3 terminals 1 & 2 (see the schematic on page 6 and the photo on page 5).

DE-ENERGIZING THE BPU



WARNING

Review all prior **WARNINGS** and **CAUTIONS** in this instruction before proceeding.

1. Shut off power to the unit.
2. Remove the 10 cover screws (M8 x 1.25 x 30mm), then carefully remove the cover to gain access to the circuit board assembly. **DO NOT FORCEFULLY REMOVE THE COVER**—this may cause damage to the mating surfaces. If needed, use jacking screws (recommend M8 x 1.25 x 40mm) in the appropriate holes (see back cover) to evenly separate the cover from the housing.



CAUTION

Damage sustained during setup and service (including cover removal and replacement) resulting from improper handling is not covered under warranty. Beck cannot be liable for any such damage which includes, but is not limited to, damage to the BPU cover-to-body interface which will affect the integrity of the seal protecting internal components.



WARNING

LETHAL VOLTAGE POTENTIAL! Use extreme caution. The unit may still have stored power.

3. Carefully set S1 (control switch, see page 5) to the 'discharge' position (downward towards the Beck logo) to begin the discharge cycle. This will drain the ultra-capacitors of stored energy. Do not touch any other components!
4. Wait approximately one hour until all the LEDs are off before proceeding.
5. As an extra precaution, use a voltmeter to measure the voltage across both terminals of TB6 (see page 5 for location). If less than 2 V, use the voltmeter to measure the terminals across TB7. If this voltage is also less than 2 V, the board is safe.

NOTE: Although unlikely, if either TB6 or TB7 have voltage higher than 2 V, but the LEDs are off, at least one of the LEDs may need to be replaced. Wait another hour, then remeasure the voltage across TB6 & TB7 to ensure less than 2 V are present. Return to the factory for LED replacement.

SERVICE

No routine maintenance is required. The only customer-replaceable item on the BPU is the gasket between the unit and the cover. If the gasket sustains damage during cover removal, it may be replaced with Beck part no. 20-0661-90 using the following procedure:



WARNING

Review all prior **WARNINGS** and **CAUTIONS** in this instruction before proceeding.

Only use Beck silicone gasket part no. 20-0661-90. Failure to comply may result in component damage.

1. Ensure the environment is non-hazardous before proceeding.
2. Shut off power to the unit.
3. If the cover is still on the unit, remove the 10 cover screws (M8 x 1.25 x 30mm), then carefully remove the cover to gain access to the gasket. **DO NOT FORCEFULLY REMOVE THE COVER**—this may cause damage to the mating surfaces. If needed, use jacking screws (recommend M8 x 1.25 x 40mm) in the appropriate holes (see back cover) to evenly separate the cover from the housing.



CAUTION

Damage sustained during setup and service (including cover removal and replacement) resulting from improper handling is not covered under warranty. Beck cannot be liable for any such damage which includes, but is not limited to, damage to the BPU cover-to-body interface which will affect the integrity of the seal protecting internal components.



WARNING

LETHAL VOLTAGE POTENTIAL! Use extreme caution. The unit may still have stored power. Do not come in contact with the circuit board assembly.

4. Completely remove the gasket from the cover mating surface of the BPU. The gasket is silicone based with a self-adhering strip and sets within the groove.

5. Ensure the groove is clean. Remove the backing from the self-adhering strip on the new gasket. Orient the gasket so that the adhesive is toward the groove on the mating surface of the unit.
6. The gasket should be mounted completely and smoothly within the groove (no kinks).
7. Ensure switch S1 is in the desired position.
8. Carefully replace the cover. **DO NOT FORCEFULLY REPLACE THE COVER**—this may cause damage to the mating surfaces. Torque the cover screws to 18 lb-ft (24 N•m).
9. Energize input power to resume normal operation.

BACKUP POWER UNIT CIRCUIT BOARD ASSEMBLY

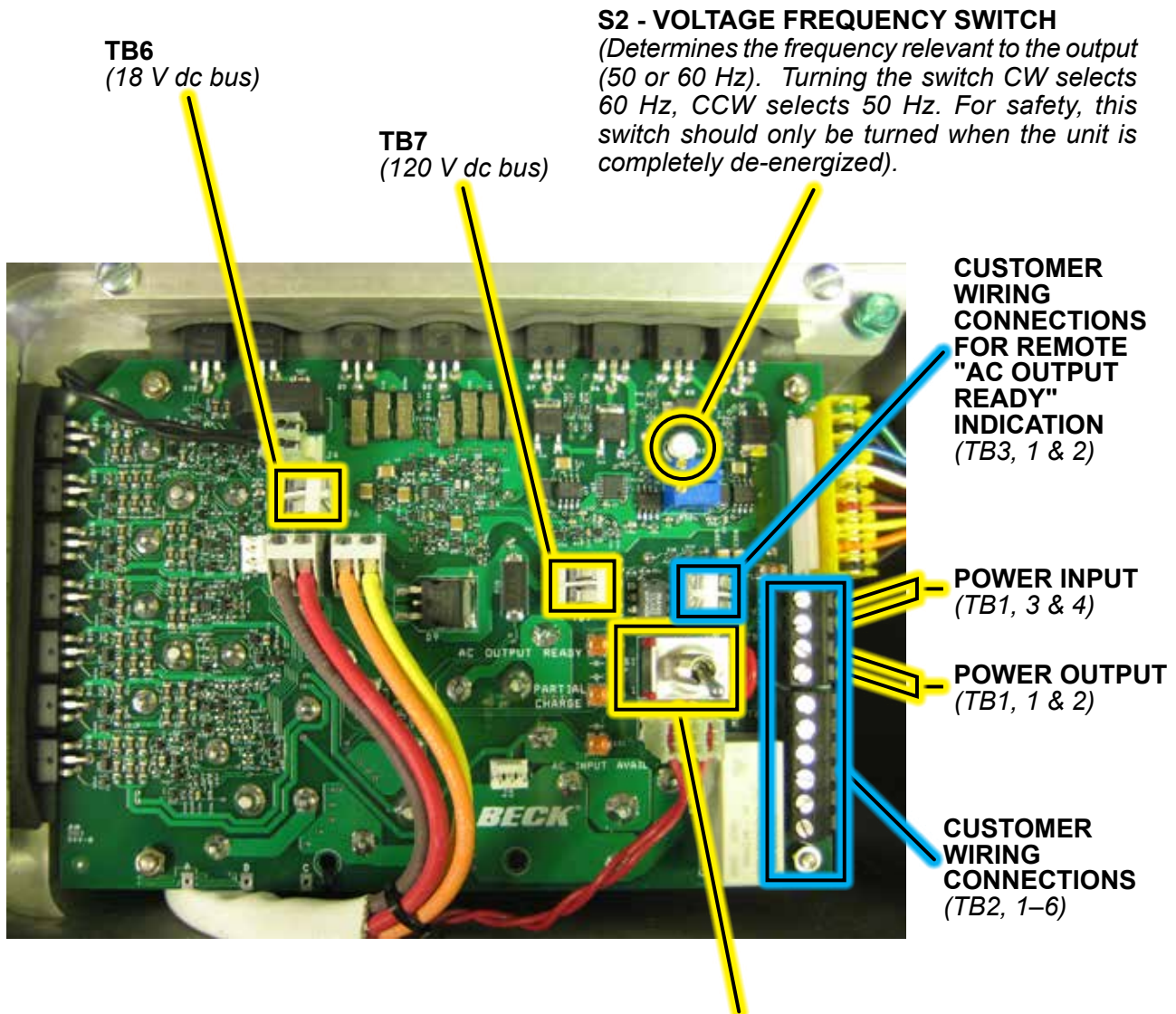

S1 - CONTROL SWITCH

(A two position switch. The 'on/charge' position (up) allows for normal operation; the 'discharge' position (shown) causes the ultra-capacitors to begin a discharge cycle—depending on the charge, it may take approx. 1 hour before the "PARTIAL CHARGE" light shuts off).

OUTLINE DIMENSIONS

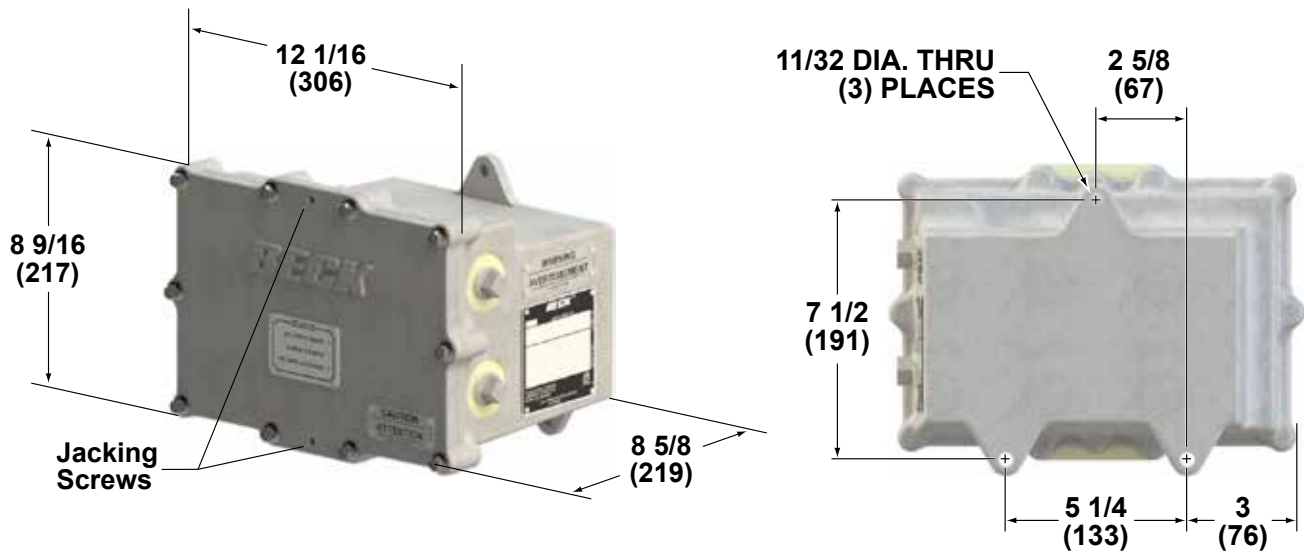

Dimensions are in inches & (mm) and are subject to change without notice

Model No.	Approximate Weight (lbs.)
20-3111-12	25.0 <11.3 kg>
20-3111-14	26.5 <12 kg>

MOUNTING HOLES (Rear View)

BACKUP POWER UNIT WIRING SCHEMATIC

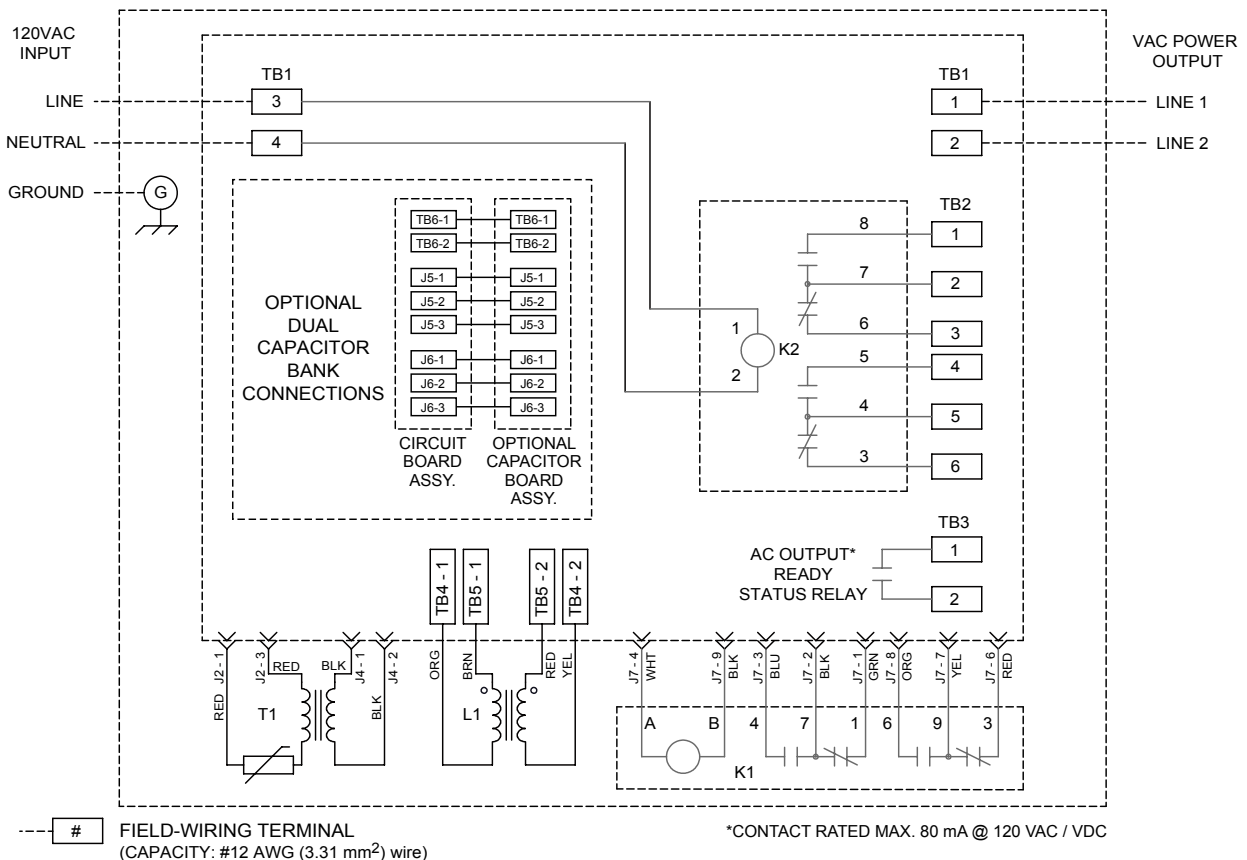

TYPICAL BPU-TO-ACTUATOR WIRING DIAGRAM

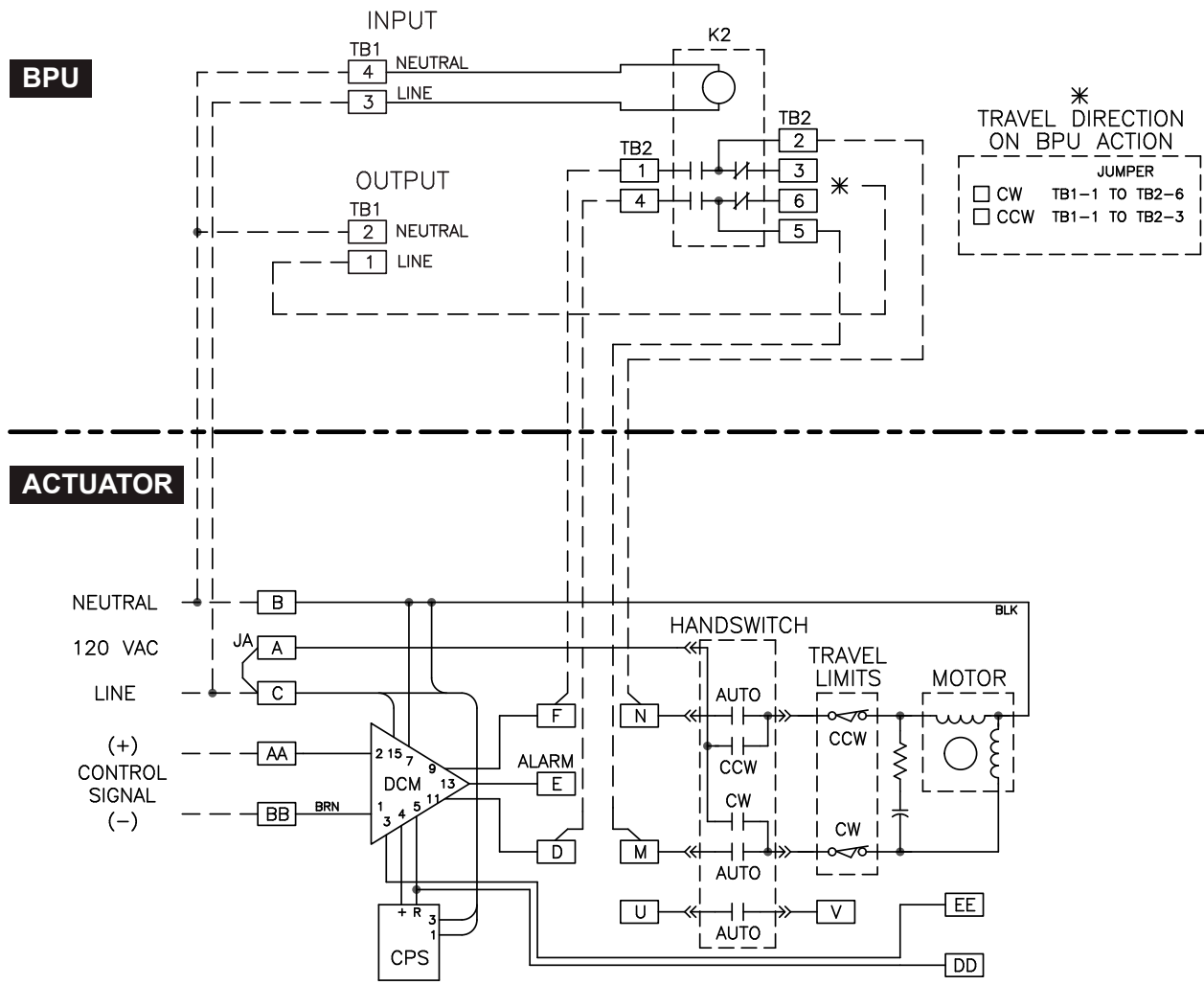

- NOTES:
1. REMOVE JUMPER JA TO PREVENT HANDSWITCH INITIATED MOTION.
 2. HANDSWITCH OVERRIDES BPU FUNCTION.

Typical wiring connections shown above are for Group 11, Option 9 actuators to run fully open or fully close upon loss of utility power. Contact the factory for assistance with your specific requirements.

BPU APPLICATION CHART

Beck Group 11 (120 V)						20-3111-12	20-3111-14
Model	Torque	Timing (100°)*	Timing (90°)	Motor Current (A)	Watts	Single Bank OK	Dual Bank OK
11-150 / -160	15	11	9.9	0.31	39.2	Yes	Yes
	20	20	18	0.17	22.4	Yes	Yes
	40	20	18	0.31	39.2	Yes	Yes
	40	40	36	0.17	22.4	Yes	Yes
	60	60	54	0.17	22.4	Yes	Yes
	80	24	21.6	0.32	40.4	Yes	Yes
	80	40	36	0.31	39.2	Yes	Yes
	80	90	81	0.17	22.4	Yes	Yes
11-200 / -260	125	20	18	0.71	87.2	Yes	Yes
	125	40	36	0.43	53.6	Yes	Yes
	175	60	54	0.43	53.6	Yes	Yes
	250	24	21.6	0.74	90.8	Yes	Yes
	250	40	36	0.71	87.2	Yes	Yes
	250	75	67.5	0.43	53.6	No	Yes
11-300 / -360	300	24	21.6	0.74	90.8	Yes	Yes
	300	40	36	0.71	87.2	Yes	Yes
	300	100	90	0.43	53.6	No	Yes
	400	36	32.4	0.74	90.8	Yes	Yes
	400	60	54	0.71	87.2	No	Yes
	550	45	40.5	0.74	90.8	No	Yes
	550	75	67.5	0.71	87.2	No	Yes
	650	60	54	0.74	90.8	No	Yes
650	100	90	0.71	87.2	No	No	

* Applies to models 11-150, 11-200 and 11-300 only.



BECK[®] HAROLD BECK & SONS, INC.

11 TERRY DRIVE • NEWTOWN, PENNSYLVANIA 18940 • USA
 PHONE: 215-968-4600 • FAX: 215-860-6383 • E-MAIL: sales@haroldbeck.com
www.haroldbeck.com

Made in USA